

DHTX CARBIDE ANNULAR CUTTER WITH X-TYPE WELDON SHANK AND HARD CUTTING

硬质合金X型直角柄硬切削钢板钻

- 适用HRC50的被加工材料;
- 高强度硬质合金刀片与硬材料专用切削几何;
- 推荐采用油性切削液;
- Applicable processing material with HRC50;
- High-strength carbide tips and special cutting geometries for hard materials;
- Oily cutting oil is recommended;

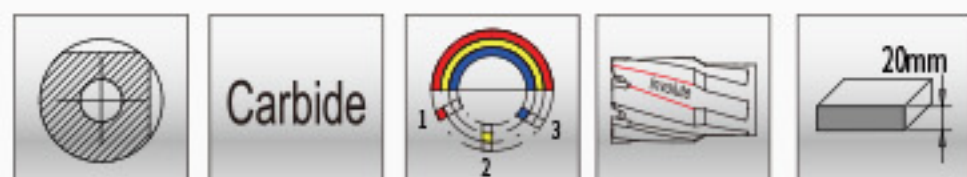
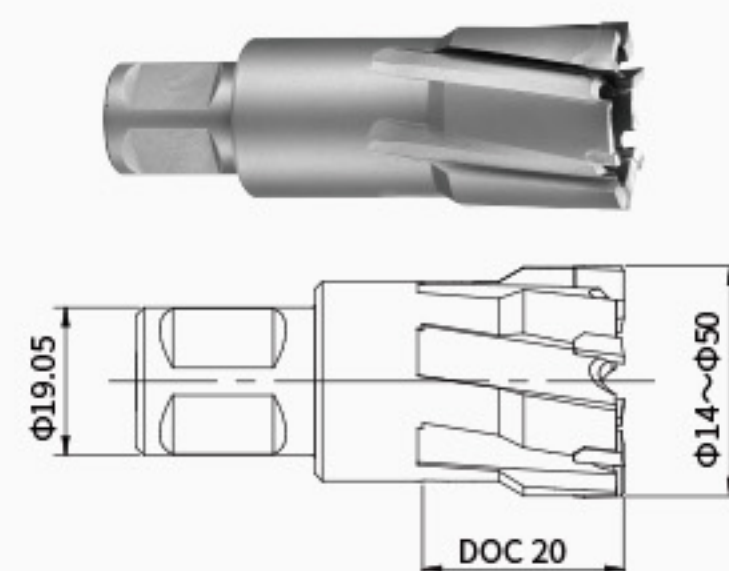

单位(Unit): mm

型号 MODEL	规格 SPECIFICATION	型号 MODEL	规格 SPECIFICATION	型号 MODEL	规格 SPECIFICATION	型号 MODEL	规格 SPECIFICATION
DHTX-20140	14*20	DHTX-20240	24*20	DHTX-20340	34*20	DHTX-20440	44*20
DHTX-20150	15*20	DHTX-20250	25*20	DHTX-20350	35*20	DHTX-20450	45*20
DHTX-20160	16*20	DHTX-20260	26*20	DHTX-20360	36*20	DHTX-20460	46*20
DHTX-20170	17*20	DHTX-20270	27*20	DHTX-20370	37*20	DHTX-20470	47*20
DHTX-20180	18*20	DHTX-20280	28*20	DHTX-20380	38*20	DHTX-20480	48*20
DHTX-20190	19*20	DHTX-20290	29*20	DHTX-20390	39*20	DHTX-20490	49*20
DHTX-20200	20*20	DHTX-20300	30*20	DHTX-20400	40*20	DHTX-20500	50*20
DHTX-20210	21*20	DHTX-20310	31*20	DHTX-20410	41*20		
DHTX-20220	22*20	DHTX-20320	32*20	DHTX-20420	42*20		
DHTX-20230	23*20	DHTX-20330	33*20	DHTX-20430	43*20		

选配件 OPTIONAL ACCESSORIES

匹配顶针 MATCHING PILOT PIN				推荐钻机 RECOMMENDED MAGNETIC DRILLING MACHINE		
钻头直径 DIAMETER	型号 MODEL	规格 SPECIFICATION	顶针 PILOT PIN	钻头直径 DIAMETER	钻机型号 MAGNETIC DRILLING MACHINE	匹配夹具 MATCHING TOOL HOLDER
14-50	DPB-62077	6.34*77		14-50	DX-60	DJXY-50X-MT3
					DX120	DJXY-50X-MT4

DHTX CARBIDE ANNULAR CUTTER WITH X-TYPE WELDON SHANK AND HARD CUTTING

硬质合金X型直角柄硬切削钢板钻

- 适用HRC50的被加工材料;
- 高强度硬质合金刀片与硬材料专用切削几何;
- 推荐采用油性切削液;
- Applicable processing material with HRC50;
- High-strength carbide tips and special cutting geometries for hard materials;
- Oily cutting oil is recommended;

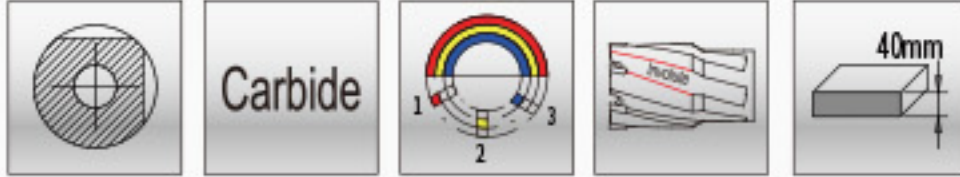
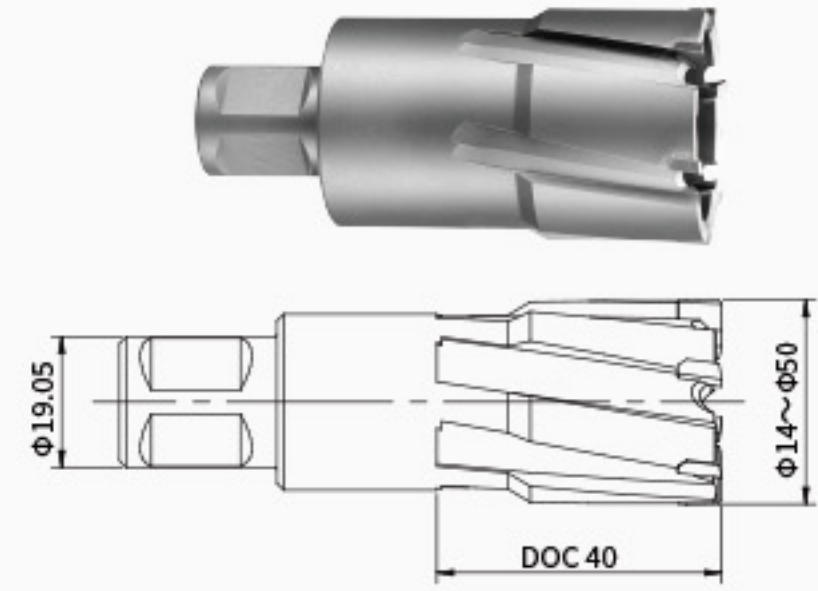

单位(Unit): mm

型号 MODEL	规格 SPECIFICATION	型号 MODEL	规格 SPECIFICATION	型号 MODEL	规格 SPECIFICATION	型号 MODEL	规格 SPECIFICATION
DHTX-40140	14*40	DHTX-40240	24*40	DHTX-40340	34*40	DHTX-40440	44*40
DHTX-40150	15*40	DHTX-40250	25*40	DHTX-40350	35*40	DHTX-40450	45*40
DHTX-40160	16*40	DHTX-40260	26*40	DHTX-40360	36*40	DHTX-40460	46*40
DHTX-40170	17*40	DHTX-40270	27*40	DHTX-40370	37*40	DHTX-40470	47*40
DHTX-40180	18*40	DHTX-40280	28*40	DHTX-40380	38*40	DHTX-40480	48*40
DHTX-40190	19*40	DHTX-40290	29*40	DHTX-40390	39*40	DHTX-40490	49*40
DHTX-40200	20*40	DHTX-40300	30*40	DHTX-40400	40*40	DHTX-40500	50*40
DHTX-40210	21*40	DHTX-40310	31*40	DHTX-40410	41*40		
DHTX-40220	22*40	DHTX-40320	32*40	DHTX-40420	42*40		
DHTX-40230	23*40	DHTX-40330	33*40	DHTX-40430	43*40		

选配件 OPTIONAL ACCESSORIES

匹配顶针 MATCHING PILOT PIN				推荐钻机 RECOMMENDED MAGNETIC DRILLING MACHINE		
钻头直径 DIAMETER	型号 MODEL	规格 SPECIFICATION	顶针 PILOT PIN	钻头直径 DIAMETER	钻机型号 MAGNETIC DRILLING MACHING	匹配夹具 MATCHING TOOL HOLDER
14-50	DPB-62102	6.34*102		14-50	DX-60	DJXY-50X-MT3
					DX120	DJXY-50X-MT4