

DNTC CARBIDE TIPPED ANNULAR CUTTER WITH C-TYPE UNIVERSAL SHANK 硬质合金C型通用柄钢板钻

- 通用柄型, 适合各种钻机接口;
- 专用硬质合金刀片, 分层及低摩擦力切削几何;
- 适合多种磁座钻机、钻床等设备上钻孔与环形槽加工。
- Universal shank, suitable for various magnetic drilling machines;
- Special carbide tips with layered and low friction cutting geometry
- Applicable to drilling and process of annular groove on various magnetic drilling machines and press.

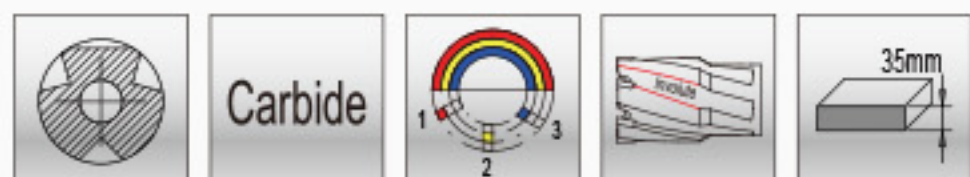
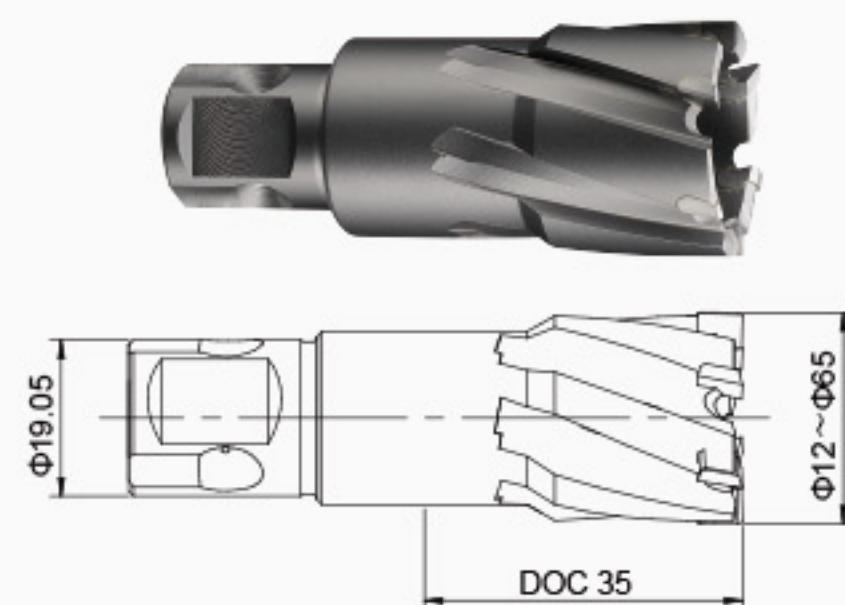

单位(Unit): mm

型号 MODEL	规格 SPECIFICATION	型号 MODEL	规格 SPECIFICATION	型号 MODEL	规格 SPECIFICATION	型号 MODEL	规格 SPECIFICATION
DNTC-30120	12*35	DNTC-30250	25*35	DNTC-30410	41*35	DNTC-30590	59*35
DNTC-30130	13*35	DNTC-30260	26*35	DNTC-30420	42*35	DNTC-30600	60*35
DNTC-30140	14*35	DNTC-30265	26.5*35	DNTC-30430	43*35	DNTC-30610	61*35
DNTC-30150	15*35	DNTC-30270	27*35	DNTC-30440	44*35	DNTC-30620	62*35
DNTC-30160	16*35	DNTC-30280	28*35	DNTC-30450	45*35	DNTC-30630	63*35
DNTC-30170	17*35	DNTC-30290	29*35	DNTC-30460	46*35	DNTC-30640	64*35
DNTC-30180	18*35	DNTC-30300	30*35	DNTC-30470	47*35	DNTC-30650	65*35
DNTC-30185	18.5*35	DNTC-30310	31*35	DNTC-30480	48*35		
DNTC-30190	19*35	DNTC-30320	32*35	DNTC-30490	49*35		
DNTC-30200	20*35	DNTC-30330	33*35	DNTC-30500	50*35		
DNTC-30205	20.5*35	DNTC-30335	33.5*35	DNTC-30510	51*35		
DNTC-30210	21*35	DNTC-30340	34*35	DNTC-30520	52*35		
DNTC-30215	21.5*35	DNTC-30350	35*35	DNTC-30530	53*35		
DNTC-30220	22*35	DNTC-30360	36*35	DNTC-30540	54*35		
DNTC-30225	22.5*35	DNTC-30370	37*35	DNTC-30550	55*35		
DNTC-30230	23*35	DNTC-30380	38*35	DNTC-30560	56*35		
DNTC-30240	24*35	DNTC-30390	39*35	DNTC-30570	57*35		
DNTC-30245	24.5*35	DNTC-30400	40*35	DNTC-30580	58*35		

英制规格详见P485 INCH SIZE ON P485

选配件 OPTIONAL ACCESSORIES

匹配顶针 MATCHING PILOT PIN				推荐钻机 RECOMMENDED MAGNETIC DRILLING MACHINE		
钻头直径 DIAMETER	型号 MODEL	规格 SPECIFICATION	顶针 PILOT PIN	钻头直径 DIAMETER	钻机型号 MAGNETIC DRILLING MACHING	匹配夹具 MATCHING TOOL HOLDER
Φ12-17	DPB-62090	6.34*90		12-17	DX-35	—
					DX-35	—
Φ18-65	DPB-81090	7.98*90		18-65	DX-60	DJXY-50D-MT3
					DX-120	DJXY-50X-MT4

DNTC CARBIDE TIPPED ANNULAR CUTTER WITH C-TYPE UNIVERSAL SHANK 硬质合金C型通用柄钢板钻

- 通用柄型, 适合各种钻机接口;
- 专用硬质合金刀片, 分层及低摩擦力切削几何;
- 适合多种磁座钻机、钻床等设备上钻孔与环形槽加工。
- Universal shank, suitable for various magnetic drilling machines;
- Special carbide tips with layered and low friction cutting geometry
- Applicable to drilling and process of annular groove on various magnetic drilling machines and press.

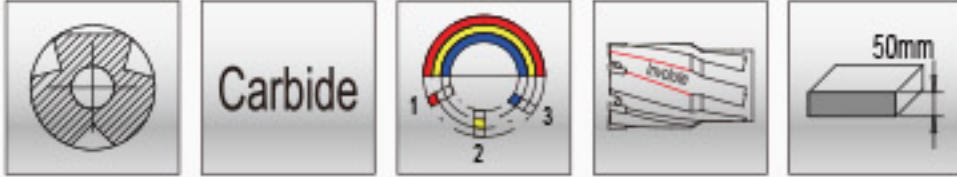
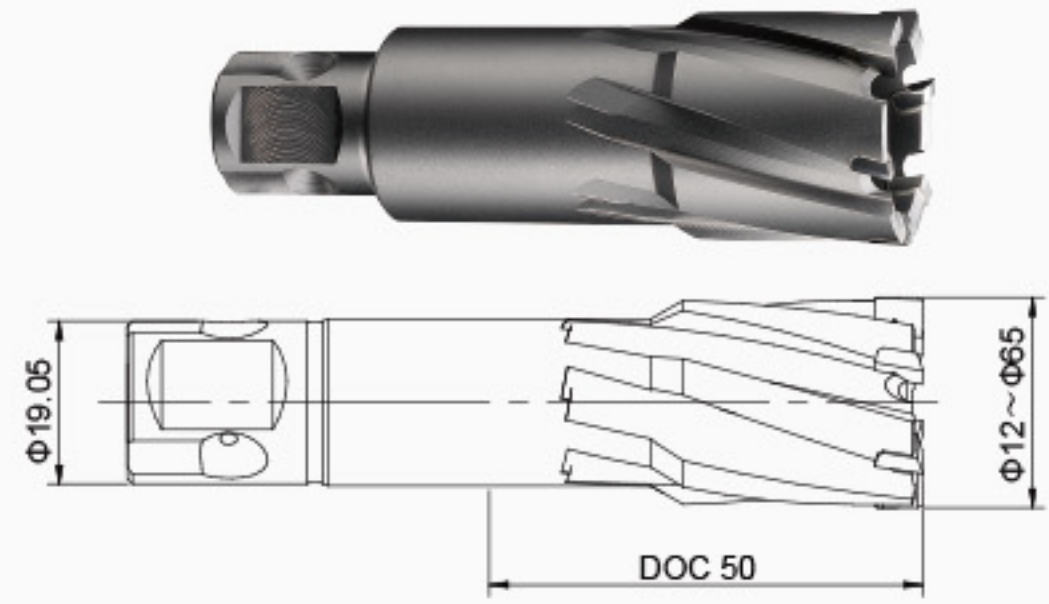

单位(Unit): mm

型号 MODEL	规格 SPECIFICATION	型号 MODEL	规格 SPECIFICATION	型号 MODEL	规格 SPECIFICATION	型号 MODEL	规格 SPECIFICATION
DNTC-40120	12*50	DNTC-40250	25*50	DNTC-40410	41*50	DNTC-40590	59*50
DNTC-40130	13*50	DNTC-40260	26*50	DNTC-40420	42*50	DNTC-40600	60*50
DNTC-40140	14*50	DNTC-40265	26.5*50	DNTC-40430	43*50	DNTC-40610	61*50
DNTC-40150	15*50	DNTC-40270	27*50	DNTC-40440	44*50	DNTC-40620	62*50
DNTC-40160	16*50	DNTC-40280	28*50	DNTC-40450	45*50	DNTC-40630	63*50
DNTC-40170	17*50	DNTC-40290	29*50	DNTC-40460	46*50	DNTC-40640	64*50
DNTC-40180	18*50	DNTC-40300	30*50	DNTC-40470	47*50	DNTC-40650	65*50
DNTC-40185	18.5*50	DNTC-40310	31*50	DNTC-40480	48*50		
DNTC-40190	19*50	DNTC-40320	32*50	DNTC-40490	49*50		
DNTC-40200	20*50	DNTC-40330	33*50	DNTC-40500	50*50		
DNTC-40205	20.5*50	DNTC-40335	33.5*50	DNTC-40510	51*50		
DNTC-40210	21*50	DNTC-40340	34*50	DNTC-40520	52*50		
DNTC-40215	21.5*50	DNTC-40350	35*50	DNTC-40530	53*50		
DNTC-40220	22*50	DNTC-40360	36*50	DNTC-40540	54*50		
DNTC-40225	22.5*50	DNTC-40370	37*50	DNTC-40550	55*50		
DNTC-40230	23*50	DNTC-40380	38*50	DNTC-40560	56*05		
DNTC-40240	24*50	DNTC-40390	39*50	DNTC-40570	57*50		
DNTC-40245	24.5*50	DNTC-40400	40*50	DNTC-40580	58*50		

英制规格详见P486 INCH SIZE ON P486

选配件 OPTIONAL ACCESSORIES

钻头直径 DIAMETER	匹配顶针 MATCHING PILOT PIN			推荐钻机 RECOMMENDED MAGNETIC DRILLING MACHINE		
	型号 MODEL	规格 SPECIFICATION	顶针 PILOT PIN	钻头直径 DIAMETER	钻机型号 MAGNETIC DRILLING MACHING	匹配夹具 MATCHING TOOL HOLDER
Φ12-17	DPB-62102	6.34*102		12-17	DX-35	—
					DX-35	—
Φ18-65	DPB-81102	7.98*102		18-65	DX-60	DJXY-50D-MT3
					DX-120	DJXY-50X-MT4

DNTC CARBIDE TIPPED ANNULAR CUTTER WITH C-TYPE UNIVERSAL SHANK 硬质合金C型通用柄钢板钻

- 通用柄型, 适合各种钻机接口;
- 专用硬质合金刀片, 分层及低摩擦力切削几何;
- 适合多种磁座钻机、钻床等设备上钻孔与环形槽加工。
- Universal shank, suitable for various magnetic drilling machines;
- Special carbide tips with layered and low friction cutting geometry
- Applicable to drilling and process of annular groove on various magnetic drilling machines and press.

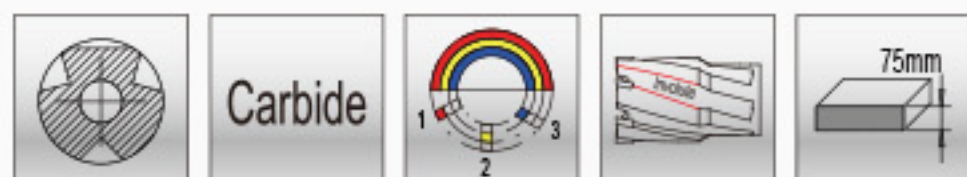
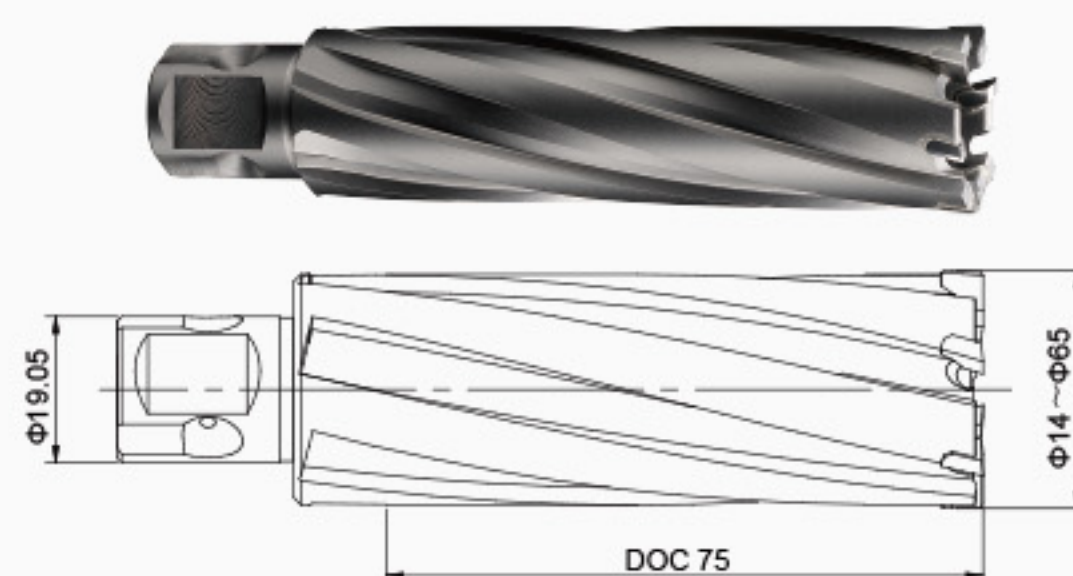

单位(Unit): mm

型号 MODEL	规格 SPECIFICATION	型号 MODEL	规格 SPECIFICATION	型号 MODEL	规格 SPECIFICATION	型号 MODEL	规格 SPECIFICATION
DNTC-50140	14*75	DNTC-50270	27*75	DNTC-50400	40*75	DNTC-50530	53*75
DNTC-50150	15*75	DNTC-50280	28*75	DNTC-50410	41*75	DNTC-50540	54*75
DNTC-50160	16*75	DNTC-50290	29*75	DNTC-50420	42*75	DNTC-50550	55*75
DNTC-50170	17*75	DNTC-50300	30*75	DNTC-50430	43*75	DNTC-50560	56*75
DNTC-50180	18*75	DNTC-50310	31*75	DNTC-50440	44*75	DNTC-50570	57*75
DNTC-50190	19*75	DNTC-50320	32*75	DNTC-50450	45*75	DNTC-50580	58*75
DNTC-50200	20*75	DNTC-50330	33*75	DNTC-50460	46*75	DNTC-50590	59*75
DNTC-50210	21*75	DNTC-50340	34*75	DNTC-50470	47*75	DNTC-50600	60*75
DNTC-50220	22*75	DNTC-50350	35*75	DNTC-50480	48*75	DNTC-50610	61*75
DNTC-50230	23*75	DNTC-50360	36*75	DNTC-50490	49*75	DNTC-50620	62*75
DNTC-50240	24*75	DNTC-50370	37*75	DNTC-50500	50*75	DNTC-50630	63*75
DNTC-50250	25*75	DNTC-50380	38*75	DNTC-50510	51*75	DNTC-50640	64*75
DNTC-50260	26*75	DNTC-50390	39*75	DNTC-50520	52*75	DNTC-50650	65*75

英制规格详见P487 INCH SIZE ON P487

选配件 OPTIONAL ACCESSORIES

匹配顶针 MATCHING PILOT PIN				推荐钻机 RECOMMENDED MAGNETIC DRILLING MACHINE		
钻头直径 DRILL DIAMETER	型号 MODEL	规格 SPECIFICATION	顶针 PILOT PIN	钻头直径 DIAMETER	钻机型号 MAGNETIC DRILLING MACHINE	匹配夹具 MATCHING TOOL HOLDER
$\Phi 14-17$	DPB-62130	6.34*130		14-17	DX-60	DJXY-75X-MT3
$\Phi 18-65$	DPB-81130	7.98*130		18-65	DX-60	DJXY-75X-MT3
					DX-120	DJXY-75X-MT4

DNTC CARBIDE TIPPED ANNULAR CUTTER WITH C-TYPE UNIVERSAL SHANK 硬质合金C型通用柄钢板钻

- 通用柄型, 适合各种钻机接口;
- 专用硬质合金刀片, 分层及低摩擦力切削几何;
- 适合多种磁座钻机、钻床等设备上钻孔与环形槽加工。
- Universal shank, suitable for various magnetic drilling machines;
- Special carbide tips with layered and low friction cutting geometry
- Applicable to drilling and process of annular groove on various magnetic drilling machines and press.

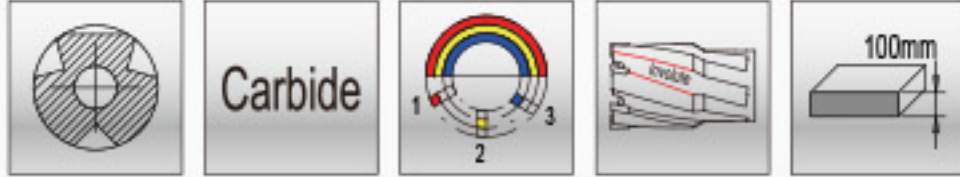
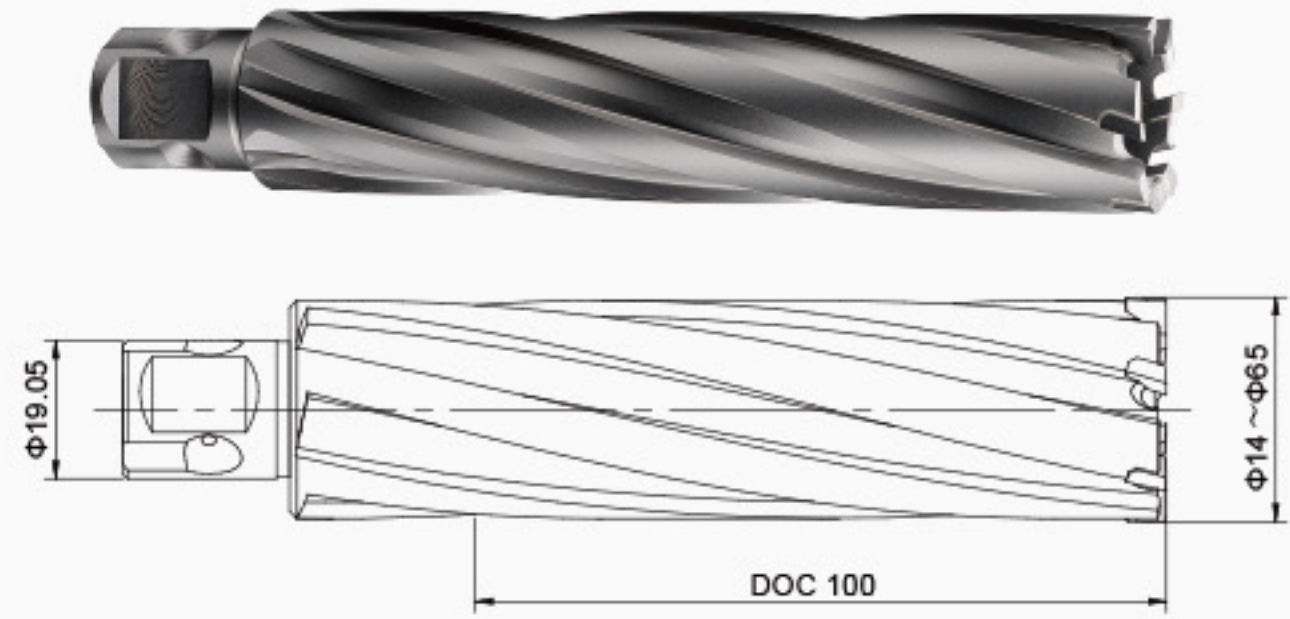

单位(Unit): mm

型号 MODEL	规格 SPECIFICATION	型号 MODEL	规格 SPECIFICATION	型号 MODEL	规格 SPECIFICATION	型号 MODEL	规格 SPECIFICATION
DNTC-60140	14*100	DNTC-60270	27*100	DNTC-60400	40*100	DNTC-60530	53*100
DNTC-60150	15*100	DNTC-60280	28*100	DNTC-60410	41*100	DNTC-60540	54*100
DNTC-60160	16*100	DNTC-60290	29*100	DNTC-60420	42*100	DNTC-60550	55*100
DNTC-60170	17*100	DNTC-60300	30*100	DNTC-60430	43*100	DNTC-60560	56*100
DNTC-60180	18*100	DNTC-60310	31*100	DNTC-60440	44*100	DNTC-60570	57*100
DNTC-60190	19*100	DNTC-60320	32*100	DNTC-60450	45*100	DNTC-60580	58*100
DNTC-60200	20*100	DNTC-60330	33*100	DNTC-60460	46*100	DNTC-60590	59*100
DNTC-60210	21*100	DNTC-60340	34*100	DNTC-60470	47*100	DNTC-60600	60*100
DNTC-60220	22*100	DNTC-60350	35*100	DNTC-60480	48*100	DNTC-60610	61*100
DNTC-60230	23*100	DNTC-60360	36*100	DNTC-60490	49*100	DNTC-60620	62*100
DNTC-60240	24*100	DNTC-60370	37*100	DNTC-60500	50*100	DNTC-60630	63*100
DNTC-60250	25*100	DNTC-60380	38*100	DNTC-60510	51*100	DNTC-60640	64*100
DNTC-60260	26*100	DNTC-60390	39*100	DNTC-60520	52*100	DNTC-60650	65*100

英制规格详见P488 INCH SIZE ON P488

选配件 OPTIONAL ACCESSORIES

匹配顶针 MATCHING PILOT PIN				推荐钻机 RECOMMENDED MAGNETIC DRILLING MACHINE		
钻头直径 DRILL DIAMETER	型号 MODEL	规格 SPECIFICATION	顶针 PILOT PIN	钻头直径 DIAMETER	钻机型号 MAGNETIC DRILLING MACHING	匹配夹具 MATCHING TOOL HOLDER
Φ14-17	DPB-62160	6.34*160		14-17	DX-120	DJXY-100X-MT4
Φ18-65	DPB-81160	7.98*160		18-65		

DNTC CARBIDE TIPPED ANNULAR CUTTER WITH C-TYPE UNIVERSAL SHANK 硬质合金C型通用柄钢板钻

- 通用柄型, 适合各种钻机接口;
- 专用硬质合金刀片, 分层及低摩擦力切削几何;
- 适合多种磁座钻机、钻床等设备上钻孔与环形槽加工。
- Universal shank, suitable for various magnetic drilling machines;
- Special carbide tips with layered and low friction cutting geometry
- Applicable to drilling and process of annular groove on various magnetic drilling machines and press.

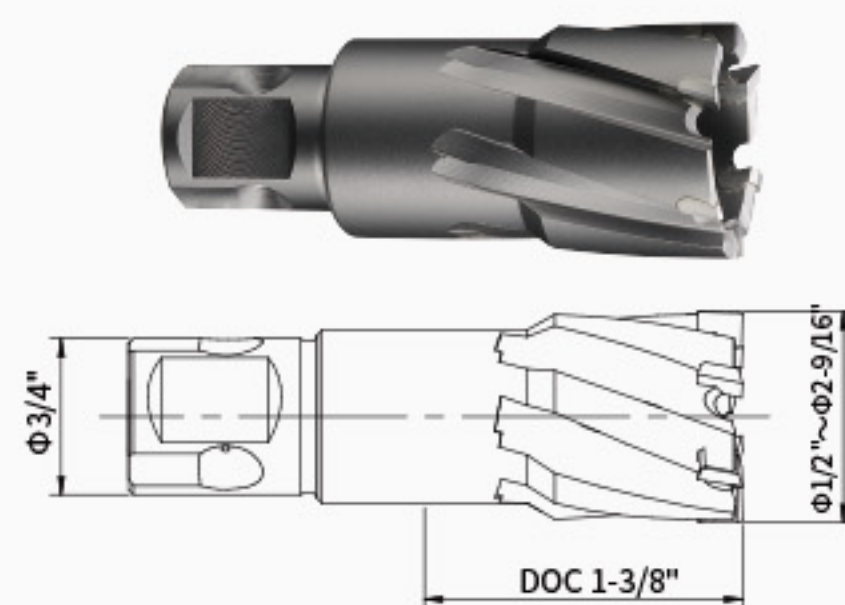

单位(Unit): inch

型号 MODEL	规格 SPECIFICATION	型号 MODEL	规格 SPECIFICATION	型号 MODEL	规格 SPECIFICATION
DNTC-C0500	1/2**1-3/8"	DNTC-C1250	1-1/4**1-3/8"	DNTC-C2000	2**1-3/8"
DNTC-C0562	9/16**1-3/8"	DNTC-C1312	1-5/16**1-3/8"	DNTC-C2062	2-1/16**1-3/8"
DNTC-C0625	5/8**1-3/8"	DNTC-C1375	1-3/8**1-3/8"	DNTC-C2125	2-1/8**1-3/8"
DNTC-C0687	11/16**1-3/8"	DNTC-C1437	1-7/16**1-3/8"	DNTC-C2187	2-3/16**1-3/8"
DNTC-C0750	3/4**1-3/8"	DNTC-C1500	1-1/2**1-3/8"	DNTC-C2250	2-1/4**1-3/8"
DNTC-C0812	13/16**1-3/8"	DNTC-C1562	1-9/16**1-3/8"	DNTC-C2312	2-5/16**1-3/8"
DNTC-C0875	7/8**1-3/8"	DNTC-C1625	1-5/8**1-3/8"	DNTC-C2375	2-3/8**1-3/8"
DNTC-C0937	15/16**1-3/8"	DNTC-C1687	1-11/16**1-3/8"	DNTC-C2437	2-7/16**1-3/8"
DNTC-C1000	1**1-3/8"	DNTC-C1750	1-3/4**1-3/8"	DNTC-C2500	2-1/2**1-3/8"
DNTC-C1062	1-1/16**1-3/8"	DNTC-C1812	1-13/16**1-3/8"	DNTC-C2562	2-9/16**1-3/8"
DNTC-C1125	1-1/8**1-3/8"	DNTC-C1875	1-7/8**1-3/8"		
DNTC-C1187	1-3/16**1-3/8"	DNTC-C1937	1-15/16**1-3/8"		

公制规格详见P453 METRIC SIZE ON P453

选配件 OPTIONAL ACCESSORIES

匹配顶针 MATCHING PILOT PIN				推荐钻机 RECOMMENDED MAGNETIC DRILLING MACHINE		
钻头直径 DIAMETER	型号 MODEL	规格 SPECIFICATION	顶针 PILOT PIN	钻头直径 DIAMETER	钻机型号 MAGNETIC DRILLING MACHING	匹配夹具 MATCHING TOOL HOLDER
Φ1/2"-11/16"	DPB-62090	6.34*90		1/2"-11/16"	DX-35	—
					DX-35	—
Φ3/4"-2-9/16"	DPB-81090	7.98*90		3/4"-2-9/16"	DX-60	DJXY-50D-MT3
					DX-120	DJXY-50X-MT4

DNTC CARBIDE TIPPED ANNULAR CUTTER WITH C-TYPE UNIVERSAL SHANK 硬质合金C型通用柄钢板钻

- 通用柄型, 适合各种钻机接口;
- 专用硬质合金刀片, 分层及低摩擦力切削几何;
- 适合多种磁座钻机、钻床等设备上钻孔与环形槽加工。
- Universal shank, suitable for various magnetic drilling machines;
- Special carbide tips with layered and low friction cutting geometry
- Applicable to drilling and process of annular groove on various magnetic drilling machines and press.

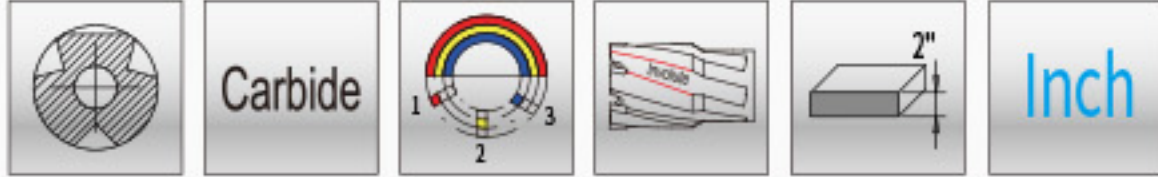
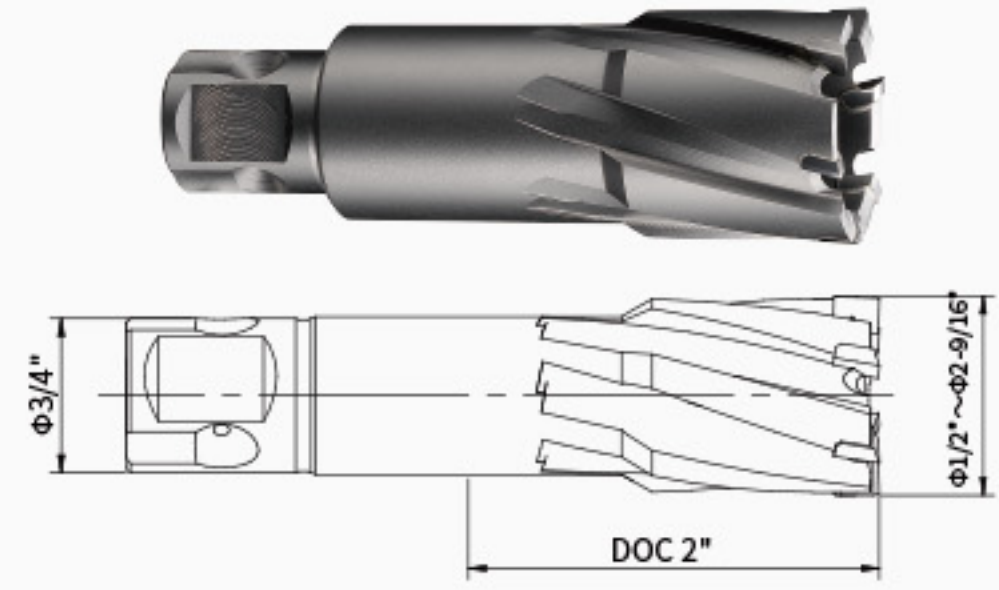

单位(Unit): inch

型号 MODEL	规格 SPECIFICATION	型号 MODEL	规格 SPECIFICATION	型号 MODEL	规格 SPECIFICATION
DNTC-D0500	1/2**2"	DNTC-D1250	1-1/4**2"	DNTC-D2000	2**2"
DNTC-D0562	9/16**2"	DNTC-D1312	1-5/16**2"	DNTC-D2062	2-1/16**2"
DNTC-D0625	5/8**2"	DNTC-D1375	1-3/8**2"	DNTC-D2125	2-1/8**2"
DNTC-D0687	11/16**2"	DNTC-D1437	1-7/16**2"	DNTC-D2187	2-3/16**2"
DNTC-D0750	3/4**2"	DNTC-D1500	1-1/2**2"	DNTC-D2250	2-1/4**2"
DNTC-D0812	13/16**2"	DNTC-D1562	1-9/16**2"	DNTC-D2312	2-5/16**2"
DNTC-D0875	7/8**2"	DNTC-D1625	1-5/8**2"	DNTC-D2375	2-3/8**2"
DNTC-D0937	15/16**2"	DNTC-D1687	1-11/16**2"	DNTC-D2437	2-7/16**2"
DNTC-D1000	1**2"	DNTC-D1750	1-3/4**2"	DNTC-D2500	2-1/2**2"
DNTC-D1062	1-1/16**2"	DNTC-D1812	1-13/16**2"	DNTC-D2562	2-9/16**2"
DNTC-D1125	1-1/8**2"	DNTC-D1875	1-7/8**2"		
DNTC-D1187	1-3/16**2"	DNTC-D1937	1-15/16**2"		

公制规格详见P454 METRIC SIZE ON P454

选配件 OPTIONAL ACCESSORIES

匹配顶针 MATCHING PILOT PIN				推荐钻机 RECOMMENDED MAGNETIC DRILLING MACHINE		
钻头直径 DRILL DIAMETER	型号 MODEL	规格 SPECIFICATION	顶针 PILOT PIN	钻头直径 DIAMETER	钻机型号 MAGNETIC DRILLING MACHING	匹配夹具 MATCHING TOOL HOLDER
Φ1/2"-11/16"	DPB-62102	6.34*102		1/2"-11/16"	DX-35	—
					DX-35	—
Φ3/4"-2-9/16"	DPB-81103	7.98*103		3/4"-2-9/16"	DX-60	DJXY-50D-MT3
					DX-120	DJXY-50X-MT4

DNTC CARBIDE TIPPED ANNULAR CUTTER WITH C-TYPE UNIVERSAL SHANK 硬质合金C型通用柄钢板钻

- 通用柄型, 适合各种钻机接口;
- 专用硬质合金刀片, 分层及低摩擦力切削几何;
- 适合多种磁座钻机、钻床等设备上钻孔与环形槽加工。
- Universal shank, suitable for various magnetic drilling machines;
- Special carbide tips with layered and low friction cutting geometry
- Applicable to drilling and process of annular groove on various magnetic drilling machines and press.

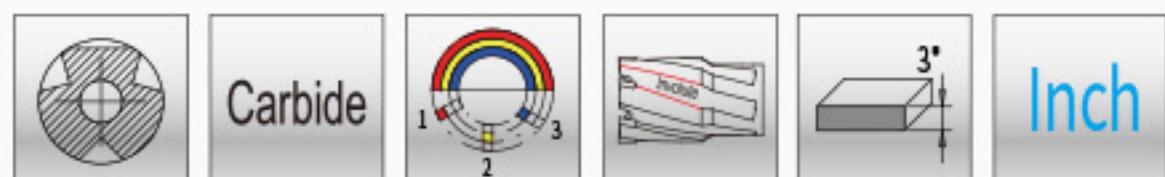
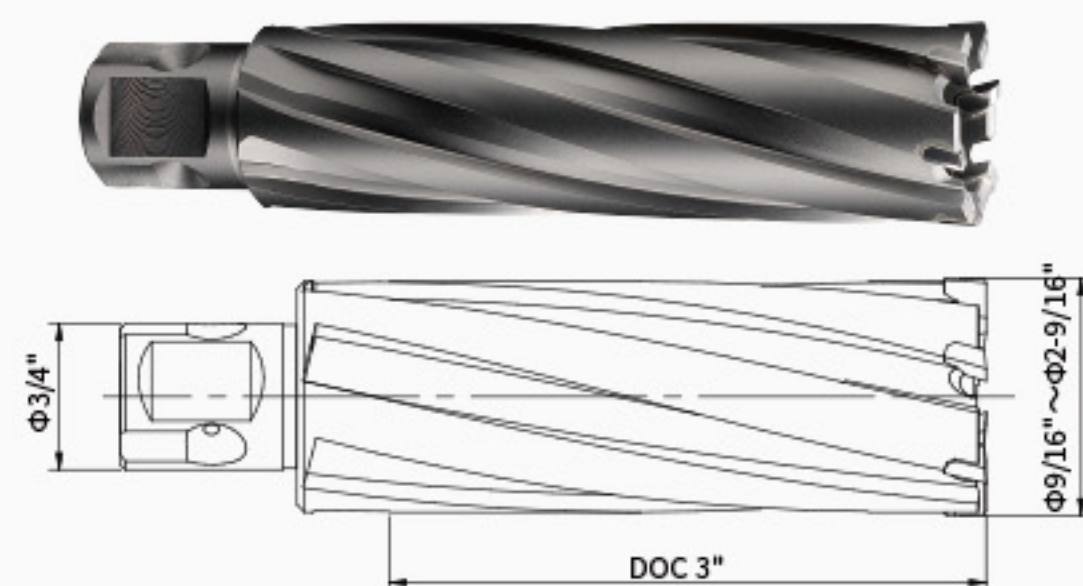

单位(Unit): inch

型号 MODEL	规格 SPECIFICATION	型号 MODEL	规格 SPECIFICATION	型号 MODEL	规格 SPECIFICATION
DNTC-E0562	9/16**3"	DNTC-E1250	1-1/4**3"	DNTC-E1937	1-15/16**3"
DNTC-E0625	5/8**3"	DNTC-E1312	1-5/16**3"	DNTC-E2000	2**3"
DNTC-E0687	11/16**3"	DNTC-E1375	1-3/8**3"	DNTC-E2062	2-1/16**3"
DNTC-E0750	3/4**3"	DNTC-E1437	1-7/16**3"	DNTC-E2125	2-1/8**3"
DNTC-E0812	13/16**3"	DNTC-E1500	1-1/2**3"	DNTC-E2187	2-3/16**3"
DNTC-E0875	7/8**3"	DNTC-E1562	1-9/16**3"	DNTC-E2250	2-1/4**3"
DNTC-E0937	15/16**3"	DNTC-E1625	1-5/8**3"	DNTC-E2312	2-5/16**3"
DNTC-E1000	1**3"	DNTC-E1687	1-11/16**3"	DNTC-E2375	2-3/8**3"
DNTC-E1062	1-1/16**3"	DNTC-E1750	1-3/4**3"	DNTC-E2437	2-7/16**3"
DNTC-E1125	1-1/8**3"	DNTC-E1812	1-13/16**3"	DNTC-E2500	2-1/2**3"
DNTC-E1187	1-3/16**3"	DNTC-E1875	1-7/8**3"	DNTC-E2562	2-9/16**3"

公制规格详见P455 METRIC SIZE ON P455

选配件 OPTIONAL ACCESSORIES

匹配顶针 MATCHING PILOT PIN				推荐钻机 RECOMMENDED MAGNETIC DRILLING MACHINE		
钻头直径 DIAMETER	型号 MODEL	规格 SPECIFICATION	顶针 PILOT PIN	钻头直径 DIAMETER	钻机型号 MAGNETIC DRILLING MACHING	匹配夹具 MATCHING TOOL HOLDER
Φ9/16"-5/8"	DPB-62130	6.34*130		Φ9/16"-5/8"	DX-60	DJXY-75X-MT3
Φ11/16"-2-9/16"	DPB-81130	7.98*130		Φ11/16"-2-9/16"	DX-60	DJXY-75X-MT3
				Φ11/16"-2-9/16"	DX-120	DJXY-75X-MT4

DNTC CARBIDE TIPPED ANNULAR CUTTER WITH C-TYPE UNIVERSAL SHANK 硬质合金C型通用柄钢板钻

- 通用柄型, 适合各种钻机接口;
- 专用硬质合金刀片, 分层及低摩擦力切削几何;
- 适合多种磁座钻机、钻床等设备上钻孔与环形槽加工。
- Universal shank, suitable for various magnetic drilling machines;
- Special carbide tips with layered and low friction cutting geometry
- Applicable to drilling and process of annular groove on various magnetic drilling machines and press.

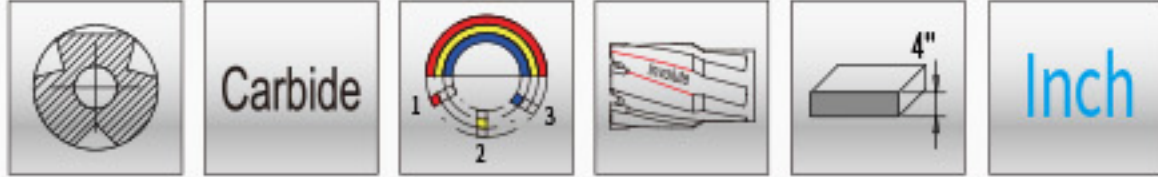
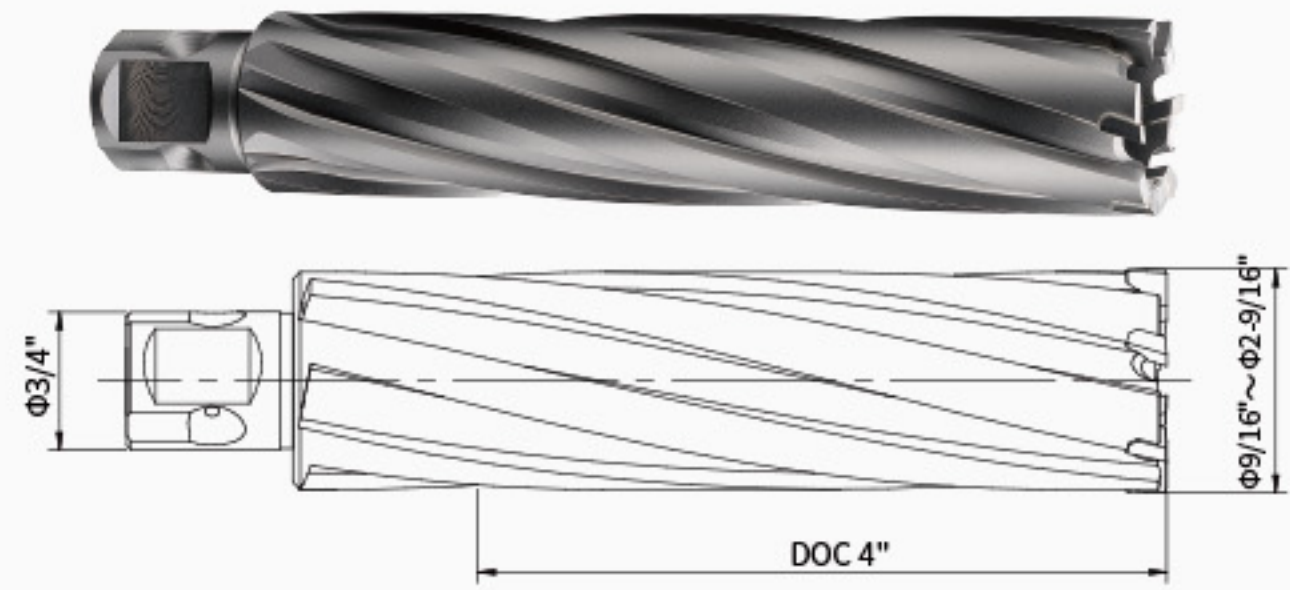

单位(Unit): inch

型号 MODEL	规格 SPECIFICATION	型号 MODEL	规格 SPECIFICATION	型号 MODEL	规格 SPECIFICATION
DNTC-F0562	9/16**4"	DNTC-F1250	1-1/4**4"	DNTC-F1937	1-15/16**4"
DNTC-F0625	5/8**4"	DNTC-F1312	1-5/16**4"	DNTC-F2000	2**4"
DNTC-F0687	11/16**4"	DNTC-F1375	1-3/8**4"	DNTC-F2062	2-1/16**4"
DNTC-F0750	3/4**4"	DNTC-F1437	1-7/16**4"	DNTC-F2125	2-1/8**4"
DNTC-F0812	13/16**4"	DNTC-F1500	1-1/2**4"	DNTC-F2187	2-3/16**4"
DNTC-F0875	7/8**4"	DNTC-F1562	1-9/16**4"	DNTC-F2250	2-1/4**4"
DNTC-F0937	15/16**4"	DNTC-F1625	1-5/8**4"	DNTC-F2312	2-5/16**4"
DNTC-F1000	1**4"	DNTC-F1687	1-11/16**4"	DNTC-F2375	2-3/8**4"
DNTC-F1062	1-1/16**4"	DNTC-F1750	1-3/4**4"	DNTC-F2437	2-7/16**4"
DNTC-F1125	1-1/8**4"	DNTC-F1812	1-13/16**4"	DNTC-F2500	2-1/2**4"
DNTC-F1187	1-3/16**4"	DNTC-F1875	1-7/8**4"	DNTC-F2562	2-9/16**4"

公制规格详见P456 METRIC SIZE ON P456

选配件 OPTIONAL ACCESSORIES

匹配顶针 MATCHING PILOT PIN				推荐钻机 RECOMMENDED MAGNETIC DRILLING MACHINE		
钻头直径 DIAMETER	型号 MODEL	规格 SPECIFICATION	顶针 PILOT PIN	钻头直径 DIAMETER	钻机型号 MAGNETIC DRILLING MACHING	匹配夹具 MATCHING TOOL HOLDER
Φ9/16"-5/8"	DPB-62160	6.34*160		Φ9/16"-5/8"	DX-120	DJXY-100X-MT4
Φ11/16"-2-9/16"	DPB-81160	7.98*160		Φ11/16"-2-9/16"		