

DNTF CARBIDE TIPPED ANNULAR CUTTER WITH FEIN QUICK-IN SHANK 硬质合金F型四孔柄钢板钻

- 四孔柄型, 适合专用钻机的快速接口;
- 专用硬质合金刀片, 分层及低摩擦力切削几何;
- Fein Quick-In shank, suitable for special purpose magnetic drilling machines;
- Special carbide tips with layered and low friction cutting geometry.

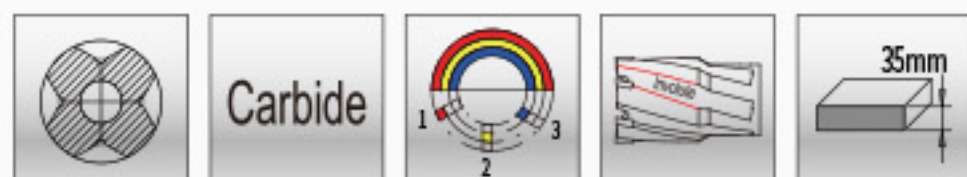

单位(Unit): mm

型号 MODEL	规格 SPECIFICATION	型号 MODEL	规格 SPECIFICATION	型号 MODEL	规格 SPECIFICATION	型号 MODEL	规格 SPECIFICATION
DNTF-30120	12*35	DNTF-30260	26*35	DNTF-30400	40*35	DNTF-30540	54*35
DNTF-30130	13*35	DNTF-30270	27*35	DNTF-30410	41*35	DNTF-30550	55*35
DNTF-30140	14*35	DNTF-30280	28*35	DNTF-30420	42*35	DNTF-30560	56*35
DNTF-30150	15*35	DNTF-30290	29*35	DNTF-30430	43*35	DNTF-30570	57*35
DNTF-30160	16*35	DNTF-30300	30*35	DNTF-30440	44*35	DNTF-30580	58*35
DNTF-30170	17*35	DNTF-30310	31*35	DNTF-30450	45*35	DNTF-30590	59*35
DNTF-30180	18*35	DNTF-30320	32*35	DNTF-30460	46*35	DNTF-30600	60*35
DNTF-30190	19*35	DNTF-30330	33*35	DNTF-30470	47*35	DNTF-30610	61*35
DNTF-30200	20*35	DNTF-30340	34*35	DNTF-30480	48*35	DNTF-30620	62*35
DNTF-30210	21*35	DNTF-30350	35*35	DNTF-30490	49*35	DNTF-30630	63*35
DNTF-30220	22*35	DNTF-30360	36*35	DNTF-30500	50*35	DNTF-30640	64*35
DNTF-30230	23*35	DNTF-30370	37*35	DNTF-30510	51*35	DNTF-30650	65*35
DNTF-30240	24*35	DNTF-30380	38*35	DNTF-30520	52*35		
DNTF-30250	25*35	DNTF-30390	39*35	DNTF-30530	53*35		

英制规格详见P501 INCH SIZE ON P501

选配件 OPTIONAL ACCESSORIES

匹配顶针 MATCHING PILOT PIN			
钻头直径 DIAMETER	型号 MODEL	规格 SPECIFICATION	顶针 PILOT PIN
12-65	DPB-62090	6.34*90	

DNTF CARBIDE TIPPED ANNULAR CUTTER WITH FEIN QUICK-IN SHANK 硬质合金F型四孔柄钢板钻

- 四孔柄型, 适合专用钻机的快速接口;
- 专用硬质合金刀片, 分层及低摩擦力切削几何;
- Fein Quick-In shank, suitable for special purpose magnetic drilling machines;
- Special carbide tips with layered and low friction cutting geometry.

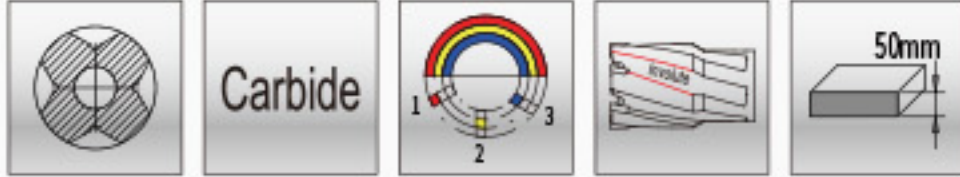
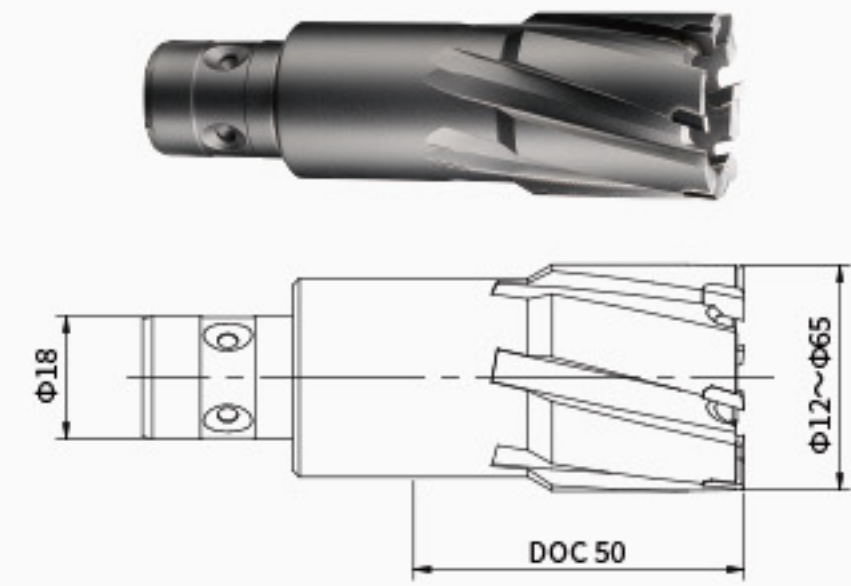

单位(Unit): mm

型号 MODEL	规格 SPECIFICATION	型号 MODEL	规格 SPECIFICATION	型号 MODEL	规格 SPECIFICATION	型号 MODEL	规格 SPECIFICATION
DNTF-40120	12*50	DNTF-40260	26*50	DNTF-40400	40*50	DNTF-40540	54*50
DNTF-40130	13*50	DNTF-40270	27*50	DNTF-40410	41*50	DNTF-40550	55*50
DNTF-40140	14*50	DNTF-40280	28*50	DNTF-40420	42*50	DNTF-40560	56*50
DNTF-40150	15*50	DNTF-40290	29*50	DNTF-40430	43*50	DNTF-40570	57*50
DNTF-40160	16*50	DNTF-40300	30*50	DNTF-40440	44*50	DNTF-40580	58*50
DNTF-40170	17*50	DNTF-40310	31*50	DNTF-40450	45*50	DNTF-40590	59*50
DNTF-40180	18*50	DNTF-40320	32*50	DNTF-40460	46*50	DNTF-40600	60*50
DNTF-40190	19*50	DNTF-40330	33*50	DNTF-40470	47*50	DNTF-40610	61*50
DNTF-40200	20*50	DNTF-40340	34*50	DNTF-40480	48*50	DNTF-40620	62*50
DNTF-40210	21*50	DNTF-40350	35*50	DNTF-40490	49*50	DNTF-40630	63*50
DNTF-40220	22*50	DNTF-40360	36*50	DNTF-40500	50*50	DNTF-40640	64*50
DNTF-40230	23*50	DNTF-40370	37*50	DNTF-40510	51*50	DNTF-40650	65*50
DNTF-40240	24*50	DNTF-40380	38*50	DNTF-40520	52*50		
DNTF-40250	25*50	DNTF-40390	39*50	DNTF-40530	53*50		

英制规格详见P502 INCH SIZE ON P502

选配件 OPTIONAL ACCESSORIES

钻头直径 DIAMETER	匹配顶针 MATCHING PILOT PIN		
	型号 MODEL	规格 SPECIFICATION	顶针 PILOT PIN
12-65	DPB-62102	6.34*102	

DNTF CARBIDE TIPPED ANNULAR CUTTER WITH FEIN QUICK-IN SHANK 硬质合金F型四孔柄钢板钻

- 四孔柄型, 适合专用钻机的快速接口;
- 专用硬质合金刀片, 分层及低摩擦力切削几何;
- Fein Quick-In shank, suitable for special purpose magnetic drilling machines;
- Special carbide tips with layered and low friction cutting geometry.

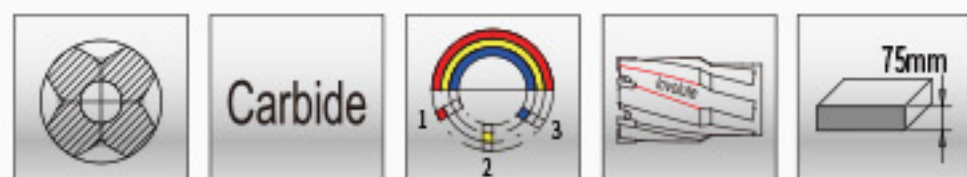
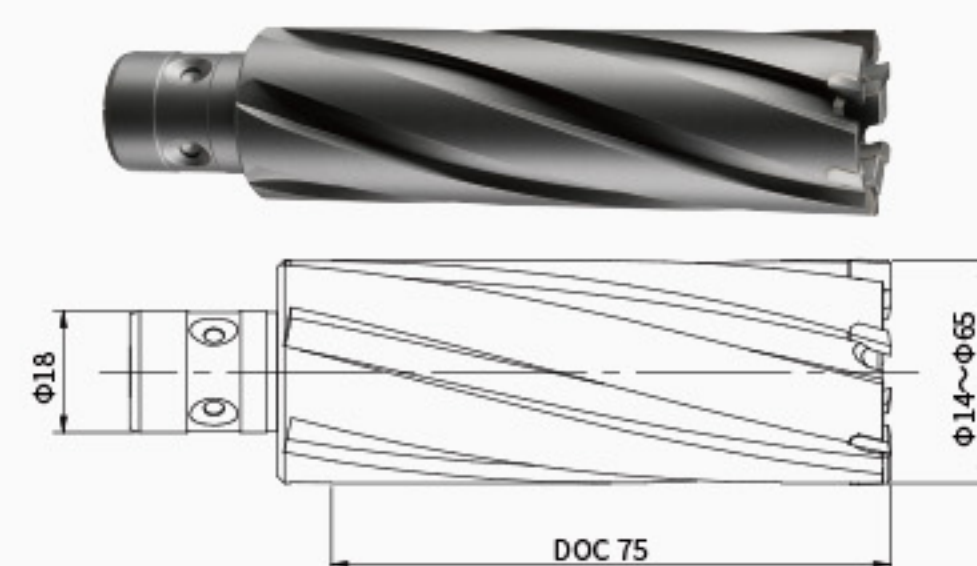

单位(Unit): mm

型号 MODEL	规格 SPECIFICATION	型号 MODEL	规格 SPECIFICATION	型号 MODEL	规格 SPECIFICATION	型号 MODEL	规格 SPECIFICATION
DNTF-50140	14*75	DNTF-50270	27*75	DNTF-50400	40*75	DNTF-50530	53*75
DNTF-50150	15*75	DNTF-50280	28*75	DNTF-50410	41*75	DNTF-50540	54*75
DNTF-50160	16*75	DNTF-50290	29*75	DNTF-50420	42*75	DNTF-50550	55*75
DNTF-50170	17*75	DNTF-50300	30*75	DNTF-50430	43*75	DNTF-50560	56*75
DNTF-50180	18*75	DNTF-50310	31*75	DNTF-50440	44*75	DNTF-50570	57*75
DNTF-50190	19*75	DNTF-50320	32*75	DNTF-50450	45*75	DNTF-50580	58*75
DNTF-50200	20*75	DNTF-50330	33*75	DNTF-50460	46*75	DNTF-50590	59*75
DNTF-50210	21*75	DNTF-50340	34*75	DNTF-50470	47*75	DNTF-50600	60*75
DNTF-50220	22*75	DNTF-50350	35*75	DNTF-50480	48*75	DNTF-50610	61*75
DNTF-50230	23*75	DNTF-50360	36*75	DNTF-50490	49*75	DNTF-50620	62*75
DNTF-50240	24*75	DNTF-50370	37*75	DNTF-50500	50*75	DNTF-50630	63*75
DNTF-50250	25*75	DNTF-50380	38*75	DNTF-50510	51*75	DNTF-50640	64*75
DNTF-50260	26*75	DNTF-50390	39*75	DNTF-50520	52*75	DNTF-50650	65*75

英制规格详见P503 INCH SIZE ON P503

选配件 OPTIONAL ACCESSORIES

钻头直径 DIAMETER	匹配顶针 MATCHING PILOT PIN		
	型号 MODEL	规格 SPECIFICATION	顶针 PILOT PIN
14-65	DPB-62130	6.34*130	

DNTF CARBIDE TIPPED ANNULAR CUTTER WITH FEIN QUICK-IN SHANK 硬质合金F型四孔柄钢板钻

- 四孔柄型, 适合专用钻机的快速接口;
- 专用硬质合金刀片, 分层及低摩擦力切削几何;
- Fein Quick-In shank, suitable for special purpose magnetic drilling machines;
- Special carbide tips with layered and low friction cutting geometry.

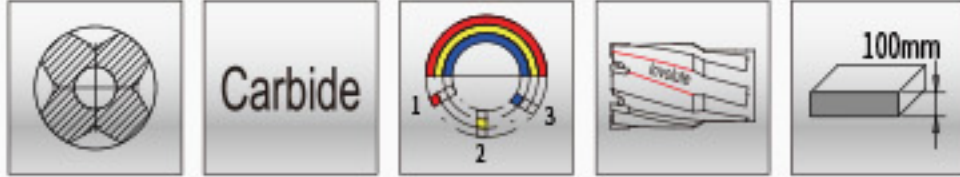
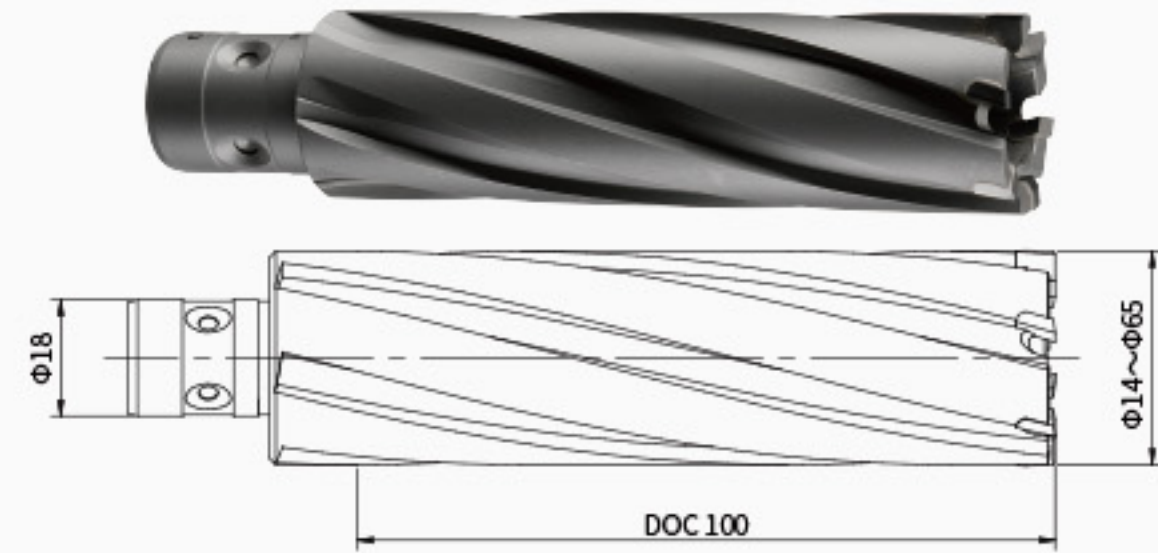

单位(Unit): mm

型号 MODEL	规格 SPECIFICATION	型号 MODEL	规格 SPECIFICATION	型号 MODEL	规格 SPECIFICATION	型号 MODEL	规格 SPECIFICATION
DNTF-60140	14*100	DNTF-60270	27*100	DNTF-60400	40*100	DNTF-60530	53*100
DNTF-60150	15*100	DNTF-60280	28*100	DNTF-60410	41*100	DNTF-60540	54*100
DNTF-60160	16*100	DNTF-60290	29*100	DNTF-60420	42*100	DNTF-60550	55*100
DNTF-60170	17*100	DNTF-60300	30*100	DNTF-60430	43*100	DNTF-60560	56*100
DNTF-60180	18*100	DNTF-60310	31*100	DNTF-60440	44*100	DNTF-60570	57*100
DNTF-60190	19*100	DNTF-60320	32*100	DNTF-60450	45*100	DNTF-60580	58*100
DNTF-60200	20*100	DNTF-60330	33*100	DNTF-60460	46*100	DNTF-60590	59*100
DNTF-60210	21*100	DNTF-60340	34*100	DNTF-60470	47*100	DNTF-60600	60*100
DNTF-60220	22*100	DNTF-60350	35*100	DNTF-60480	48*100	DNTF-60610	61*100
DNTF-60230	23*100	DNTF-60360	36*100	DNTF-60490	49*100	DNTF-60620	62*100
DNTF-60240	24*100	DNTF-60370	37*100	DNTF-60500	50*100	DNTF-60630	63*100
DNTF-60250	25*100	DNTF-60380	38*100	DNTF-60510	51*100	DNTF-60640	64*100
DNTF-60260	26*100	DNTF-60390	39*100	DNTF-60520	52*100	DNTF-60650	65*100

英制规格详见P504 INCH SIZE ON P504

选配件 OPTIONAL ACCESSORIES

钻头直径 DIAMETER	匹配顶针 MATCHING PILOT PIN		
	型号 MODEL	规格 SPECIFICATION	顶针 PILOT PIN
14-65	DPB-62160	6.34*160	

DNTF CARBIDE TIPPED ANNULAR CUTTER WITH FEIN QUICK-IN SHANK 硬质合金F型四孔柄钢板钻

- 四孔柄型, 适合专用钻机的快速接口;
- 专用硬质合金刀片, 分层及低摩擦力切削几何;
- Fein Quick-In shank, suitable for special purpose magnetic drilling machines;
- Special carbide tips with layered and low friction cutting geometry.

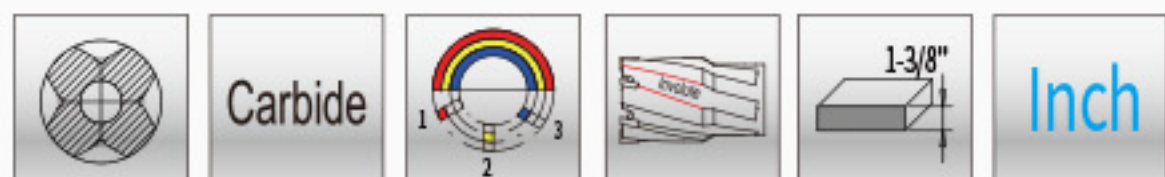

单位(Unit): inch

型号 MODEL	规格 SPECIFICATION	型号 MODEL	规格 SPECIFICATION	型号 MODEL	规格 SPECIFICATION	型号 MODEL	规格 SPECIFICATION
DNTF-C0500	1/2**1-3/8"	DNTF-C1062	1-1/16**1-3/8"	DNTF-C1625	1-5/8**1-3/8"	DNTF-C2187	2-3/16**1-3/8"
DNTF-C0562	9/16**1-3/8"	DNTF-C1125	1-1/8**1-3/8"	DNTF-C1687	1-11/16**1-3/8"	DNTF-C2250	2-1/4**1-3/8"
DNTF-C0625	5/8**1-3/8"	DNTF-C1187	1-3/16**1-3/8"	DNTF-C1750	1-3/4**1-3/8"	DNTF-C2312	2-5/16**1-3/8"
DNTF-C0687	11/16**1-3/8"	DNTF-C1250	1-1/4**1-3/8"	DNTF-C1812	1-13/16**1-3/8"	DNTF-C2375	2-3/8**1-3/8"
DNTF-C0750	3/4**1-3/8"	DNTF-C1312	1-5/16**1-3/8"	DNTF-C1875	1-7/8**1-3/8"	DNTF-C2437	2-7/16**1-3/8"
DNTF-C0812	13/16**1-3/8"	DNTF-C1375	1-3/8**1-3/8"	DNTF-C1937	1-15/16**1-3/8"	DNTF-C2500	2-1/2**1-3/8"
DNTF-C0812	7/8**1-3/8"	DNTF-C1437	1-7/16**1-3/8"	DNTF-C2000	2**1-3/8"	DNTF-C2562	2-9/16**1-3/8"
DNTF-C0937	15/16**1-3/8"	DNTF-C1500	1-1/2**1-3/8"	DNTF-C2062	2-1/16**1-3/8"		
DNTF-C1000	1**1-3/8"	DNTF-C1562	1-9/16**1-3/8"	DNTF-C2125	2-1/8**1-3/8"		

公制规格详见P473 METRIC SIZE ON P473

选配件 OPTIONAL ACCESSORIES

匹配顶针 MATCHING PILOT PIN			
钻头直径 DIAMETER	型号 MODEL	规格 SPECIFICATION	顶针 PILOT PIN
1/2"-2-9/16"	DPB-62090	6.34*90	

DNTF CARBIDE TIPPED ANNULAR CUTTER WITH FEIN QUICK-IN SHANK 硬质合金F型四孔柄钢板钻

- 四孔柄型, 适合专用钻机的快速接口;
- 专用硬质合金刀片, 分层及低摩擦力切削几何;
- Fein Quick-In shank, suitable for special purpose magnetic drilling machines;
- Special carbide tips with layered and low friction cutting geometry.

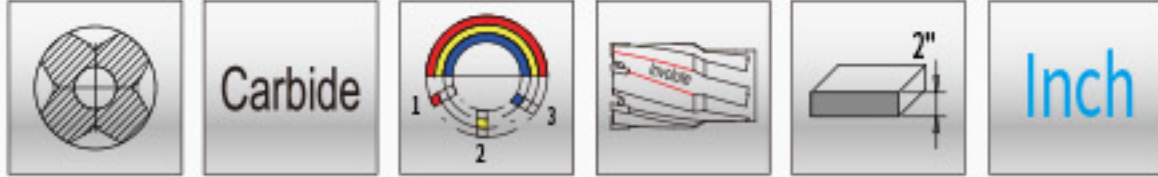
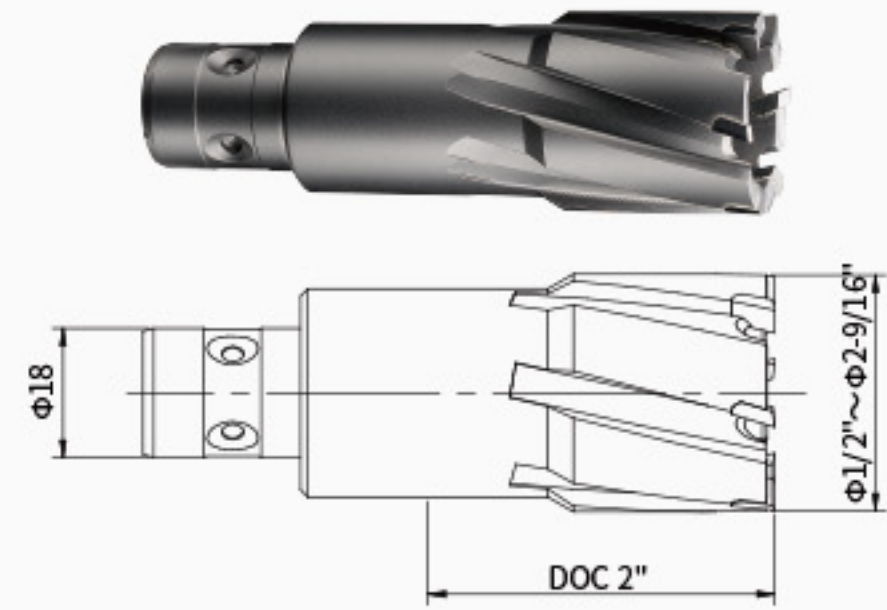

单位(Unit): inch

型号 MODEL	规格 SPECIFICATION	型号 MODEL	规格 SPECIFICATION	型号 MODEL	规格 SPECIFICATION	型号 MODEL	规格 SPECIFICATION
DNTF-D0500	1/2**2"	DNTF-D1062	1-1/16**2"	DNTF-D1625	1-5/8**2"	DNTF-D2187	2-3/16**2"
DNTF-D0562	9/16**2"	DNTF-D1125	1-1/8**2"	DNTF-D1687	1-11/16**2"	DNTF-D2250	2-1/4**2"
DNTF-D0625	5/8**2"	DNTF-D1187	1-3/16**2"	DNTF-D1750	1-3/4**2"	DNTF-D2312	2-5/16**2"
DNTF-D0687	11/16**2"	DNTF-D1250	1-1/4**2"	DNTF-D1812	1-13/16**2"	DNTF-D2375	2-3/8**2"
DNTF-D0750	3/4**2"	DNTF-D1312	1-5/16**2"	DNTF-D1875	1-7/8**2"	DNTF-D2437	2-7/16**2"
DNTF-D0812	13/16**2"	DNTF-D1375	1-3/8**2"	DNTF-D1937	1-15/16**2"	DNTF-D2500	2-1/2**2"
DNTF-D0875	7/8**2"	DNTF-D1437	1-7/16**2"	DNTF-D2000	2**2"	DNTF-D2562	2-9/16**2"
DNTF-D0937	15/16**2"	DNTF-D1500	1-1/2**2"	DNTF-D2062	2-1/16**2"		
DNTF-D1000	1**2"	DNTF-D1562	1-9/16**2"	DNTF-D2125	2-1/8**2"		

公制规格详见P474 METRIC SIZE ON P474

选配件 OPTIONAL ACCESSORIES

匹配顶针 MATCHING PILOT PIN			
钻头直径 DIAMETER	型号 MODEL	规格 SPECIFICATION	顶针 PILOT PIN
1/2"-2-9/16"	DPB-62102	6.34*102	



DNTF CARBIDE TIPPED ANNULAR CUTTER WITH FEIN QUICK-IN SHANK 硬质合金F型四孔柄钢板钻

- 四孔柄型, 适合专用钻机的快速接口;
- 专用硬质合金刀片, 分层及低摩擦力切削几何;
- Fein Quick-In shank, suitable for special purpose magnetic drilling machines;
- Special carbide tips with layered and low friction cutting geometry.



单位(Unit): inch

型号 MODEL	规格 SPECIFICATION	型号 MODEL	规格 SPECIFICATION	型号 MODEL	规格 SPECIFICATION	型号 MODEL	规格 SPECIFICATION
DNTF-E0562	9/16**3"	DNTF-E1125	1-1/8**3"	DNTF-E1687	1-11/16**3"	DNTF-E2250	2-1/4**3"
DNTF-E0625	5/8**3"	DNTF-E1187	1-3/16**3"	DNTF-E1750	1-3/4**3"	DNTF-E2312	2-5/16**3"
DNTF-E0687	11/16**3"	DNTF-E1250	1-1/4**3"	DNTF-E1812	1-13/16**3"	DNTF-E2375	2-3/8**3"
DNTF-E0750	3/4**3"	DNTF-E1312	1-5/16**3"	DNTF-E1875	1-7/8**3"	DNTF-E2437	2-7/16**3"
DNTF-E0812	13/16**3"	DNTF-E1375	1-3/8**3"	DNTF-E1937	1-15/16**3"	DNTF-E2500	2-1/2**3"
DNTF-E0875	7/8**3"	DNTF-E1437	1-7/16**3"	DNTF-E2000	2**3"	DNTF-E2562	2-9/16**3"
DNTF-E0937	15/16**3"	DNTF-E1500	1-1/2**3"	DNTF-E2062	2-1/16**3"		
DNTF-E1000	1**3"	DNTF-E1562	1-9/16**3"	DNTF-E2125	2-1/8**3"		
DNTF-E1062	1-1/16**3"	DNTF-E1625	1-5/8**3"	DNTF-E2187	2-3/16**3"		

公制规格详见P475 METRIC SIZE ON P475

选配件 OPTIONAL ACCESSORIES

匹配顶针 MATCHING PILOT PIN			
钻头直径 DIAMETER	型号 MODEL	规格 SPECIFICATION	顶针 PILOT PIN
9/16"-2-9/16"	DPB-62130	6.34*130	

DNTF CARBIDE TIPPED ANNULAR CUTTER WITH FEIN QUICK-IN SHANK 硬质合金F型四孔柄钢板钻

- 四孔柄型, 适合专用钻机的快速接口;
- 专用硬质合金刀片, 分层及低摩擦力切削几何;
- Fein Quick-In shank, suitable for special purpose magnetic drilling machines;
- Special carbide tips with layered and low friction cutting geometry.

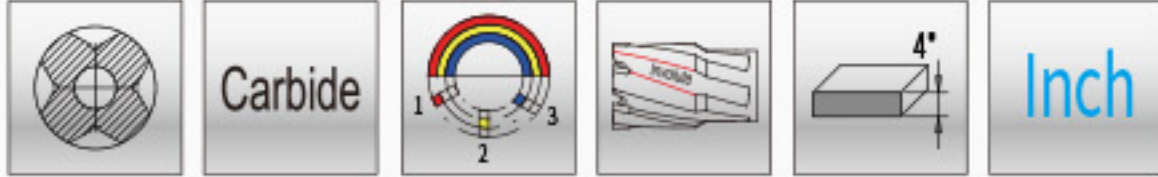
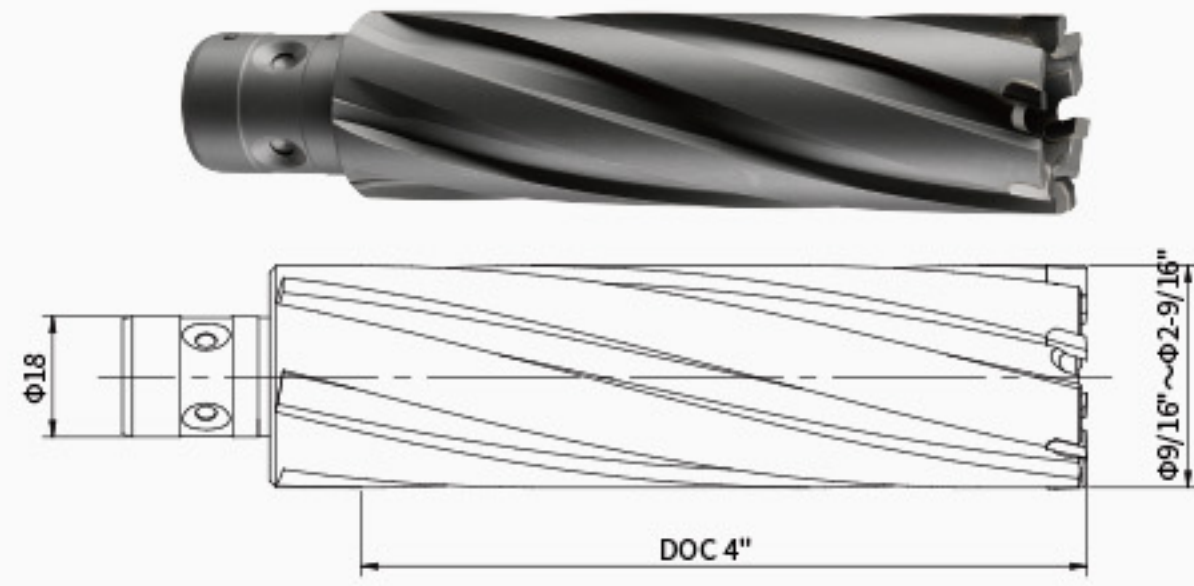

单位(Unit): inch

型号 MODEL	规格 SPECIFICATION	型号 MODEL	规格 SPECIFICATION	型号 MODEL	规格 SPECIFICATION	型号 MODEL	规格 SPECIFICATION
DNTF-F0562	9/16**4"	DNTF-F1125	1-1/8**4"	DNTF-F1687	1-11/16**4"	DNTF-F2250	2-1/4**4"
DNTF-F0625	5/8**4"	DNTF-F1187	1-3/16**4"	DNTF-F1750	1-3/4**4"	DNTF-F2312	2-5/16**4"
DNTF-F0687	11/16**4"	DNTF-F1250	1-1/4**4"	DNTF-F1812	1-13/16**4"	DNTF-F2375	2-3/8**4"
DNTF-F0750	3/4**4"	DNTF-F1312	1-5/16**4"	DNTF-F1875	1-7/8**4"	DNTF-F2437	2-7/16**4"
DNTF-F0812	13/16**4"	DNTF-F1375	1-3/8**4"	DNTF-F1937	1-15/16**4"	DNTF-F2500	2-1/2**4"
DNTF-F0875	7/8**4"	DNTF-F1437	1-7/16**4"	DNTF-F2000	2**4"	DNTF-F2562	2-9/16**4"
DNTF-F0937	15/16**4"	DNTF-F1500	1-1/2**4"	DNTF-F2062	2-1/16**4"		
DNTF-F1000	1**4"	DNTF-F1562	1-9/16**4"	DNTF-F2125	2-1/8**4"		
DNTF-F1062	1-1/16**4"	DNTF-F1625	1-5/8**4"	DNTF-F2187	2-3/16**4"		

公制规格详见P476 METRIC SIZE ON P476

选配件 OPTIONAL ACCESSORIES

匹配顶针 MATCHING PILOT PIN			
钻头直径 DIAMETER	型号 MODEL	规格 SPECIFICATION	顶针 PILOT PIN
9/16"-2-9/16"	DPB-62160	6.34*160	

