

# DNTG CARBIDE TIPPED ANNULAR CUTTER WITH G-TYPE QUICK CHANGE SHANK 硬质合金G型三孔柄钢板钻

- 三孔柄型, 适合专用钻机接口;
- 专用硬质合金刀片, 分层及低摩擦力切削几何;
- Quick-change shank(3 holes), Suitable for special purpose magnetic drilling machines;
- Special carbide tips with layered and low friction cutting geometry

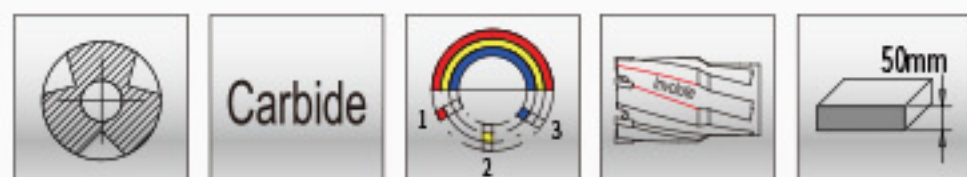
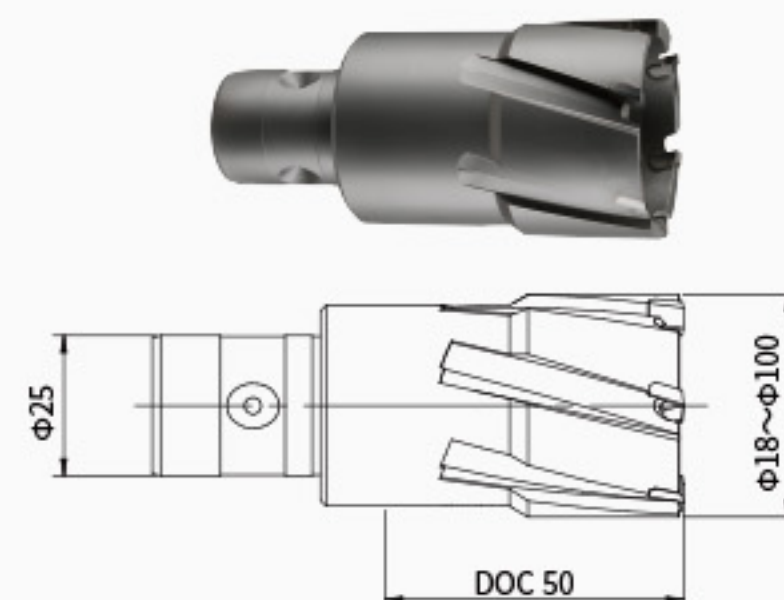

单位(Unit): mm

型号 MODEL	规格 SPECIFICATION	型号 MODEL	规格 SPECIFICATION	型号 MODEL	规格 SPECIFICATION	型号 MODEL	规格 SPECIFICATION
DNTG-40180	18*50	DNTG-40310	31*50	DNTG-40440	44*50	DNTG-40570	57*50
DNTG-40190	19*50	DNTG-40320	32*50	DNTG-40450	45*50	DNTG-40580	58*50
DNTG-40200	20*50	DNTG-40330	33*50	DNTG-40460	46*50	DNTG-40590	59*50
DNTG-40210	21*50	DNTG-40340	34*50	DNTG-40470	47*50	DNTG-40600	60*50
DNTG-40220	22*50	DNTG-40350	35*50	DNTG-40480	48*50	DNTG-40650	65*50
DNTG-40230	23*50	DNTG-40360	36*50	DNTG-40490	49*50	DNTG-40700	70*50
DNTG-40240	24*50	DNTG-40370	37*50	DNTG-40500	50*50	DNTG-40750	75*50
DNTG-40250	25*50	DNTG-40380	38*50	DNTG-40510	51*50	DNTG-40800	80*50
DNTG-40260	26*50	DNTG-40390	39*50	DNTG-40520	52*50	DNTG-40850	85*50
DNTG-40270	27*50	DNTG-40400	40*50	DNTG-40530	53*50	DNTG-40900	90*50
DNTG-40280	28*50	DNTG-40410	41*50	DNTG-40540	54*50	DNTG-40950	95*50
DNTG-40290	29*50	DNTG-40420	42*50	DNTG-40550	55*50	DNTG-41000	100*50
DNTG-40300	30*50	DNTG-40430	43*50	DNTG-40560	56*50		

## 选配件 OPTIONAL ACCESSORIES

匹配顶针 MATCHING PILOT PIN				推荐钻机 RECOMMENDED MAGNETIC DRILLING MACHINE		
钻头直径 DIAMETER	型号 MODEL	规格 SPECIFICATION	顶针 PILOT PIN	钻头直径 DIAMETER	钻机型号 MAGNETIC DRILLING MACHING	匹配夹具 MATCHING TOOL HOLDER
18-100	DPB-81115	7.98*115			—	—
				18-100	DX-60	DJGK-50X-MT3
				18-100	DX-120	DJGK-50X-MT4



# DNTG CARBIDE TIPPED ANNULAR CUTTER WITH G-TYPE QUICK CHANGE SHANK 硬质合金G型三孔柄钢板钻

- 三孔柄型, 适合专用钻机接口;
- 专用硬质合金刀片, 分层及低摩擦力切削几何;
- Quick-change shank(3 holes), Suitable for special purpose magnetic drilling machines;
- Special carbide tips with layered and low friction cutting geometry

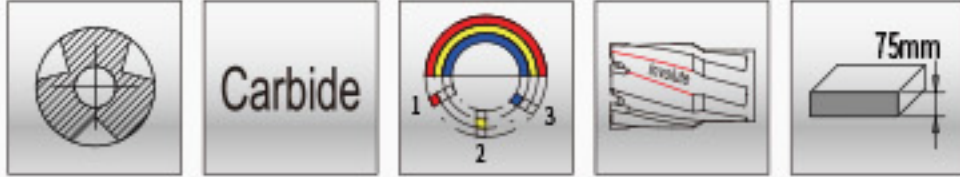
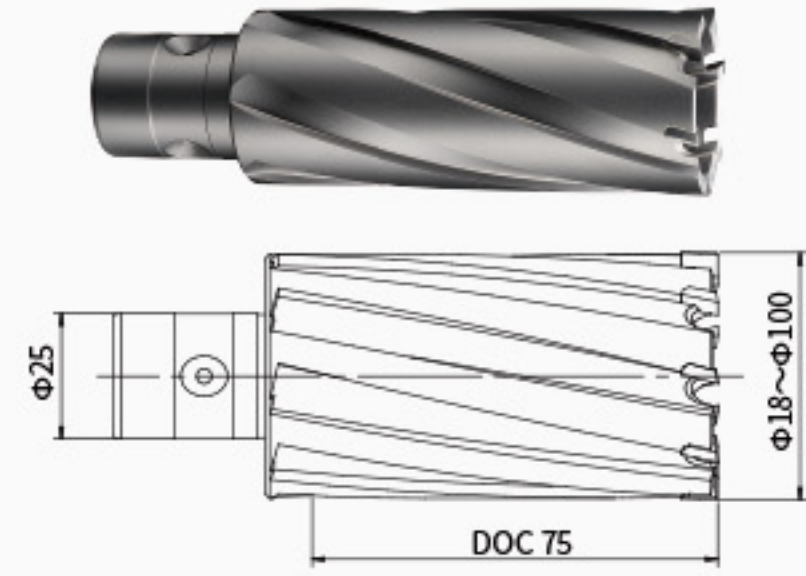

单位(Unit): mm

型号 MODEL	规格 SPECIFICATION	型号 MODEL	规格 SPECIFICATION	型号 MODEL	规格 SPECIFICATION	型号 MODEL	规格 SPECIFICATION
DNTG-50180	18*75	DNTG-50310	31*75	DNTG-50440	44*75	DNTG-50570	57*75
DNTG-50190	19*75	DNTG-50320	32*75	DNTG-50450	45*75	DNTG-50580	58*75
DNTG-50200	20*75	DNTG-50330	33*75	DNTG-50460	46*75	DNTG-50590	59*75
DNTG-50210	21*75	DNTG-50340	34*75	DNTG-50470	47*75	DNTG-50600	60*75
DNTG-50220	22*75	DNTG-50350	35*75	DNTG-50480	48*75	DNTG-50650	65*75
DNTG-50230	23*75	DNTG-50360	36*75	DNTG-50490	49*75	DNTG-50700	70*75
DNTG-50240	24*75	DNTG-50370	37*75	DNTG-50500	50*75	DNTG-50750	75*75
DNTG-50250	25*75	DNTG-50380	38*75	DNTG-50510	51*75	DNTG-50800	80*75
DNTG-50260	26*75	DNTG-50390	39*75	DNTG-50520	52*75	DNTG-50850	85*75
DNTG-50270	27*75	DNTG-50400	40*75	DNTG-50530	53*75	DNTG-50900	90*75
DNTG-50280	28*75	DNTG-50410	41*75	DNTG-50540	54*75	DNTG-50950	95*75
DNTG-50290	29*75	DNTG-50420	42*75	DNTG-50550	55*75	DNTG-51000	100*75
DNTG-50300	30*75	DNTG-50430	43*75	DNTG-50560	56*75		

## 选配件 OPTIONAL ACCESSORIES

匹配顶针 MATCHING PILOT PIN				推荐钻机 RECOMMENDED MAGNETIC DRILLING MACHINE		
钻头直径 DIAMETER	型号 MODEL	规格 SPECIFICATION	顶针 PILOT PIN	钻头直径 DIAMETER	钻机型号 MAGNETIC DRILLING MACHING	匹配夹具 MATCHING TOOL HOLDER
18-100	DPB-81134	7.98*134		18-100	DX-60	DJGK-75X-MT3
					DX-120	DJGK-75X-MT4