

DNTJ CARBIDE TIPPED ANNULAR CUTTER WITH J-TYPE WELDON SHANK 硬质合金J型削平柄钢板钻

- 削平柄型, 保证大规格钻孔时的夹持力与夹持精度, 适合直径50mm与以上规格;
- 专用硬质合金刀片, 分层及低摩擦力切削几何;
- 适合多种磁座钻机、钻床等设备上钻孔与环形槽加工;
- Parakkal shank ensures the clamping force and clamping accuracy when drilling large diameter, and it is suitable for the diameter of 50mm and above;
- Special carbide tips with layered and low friction cutting geometry;
- Applicable to drilling and process of annular groove on various magnetic drilling machines and press.

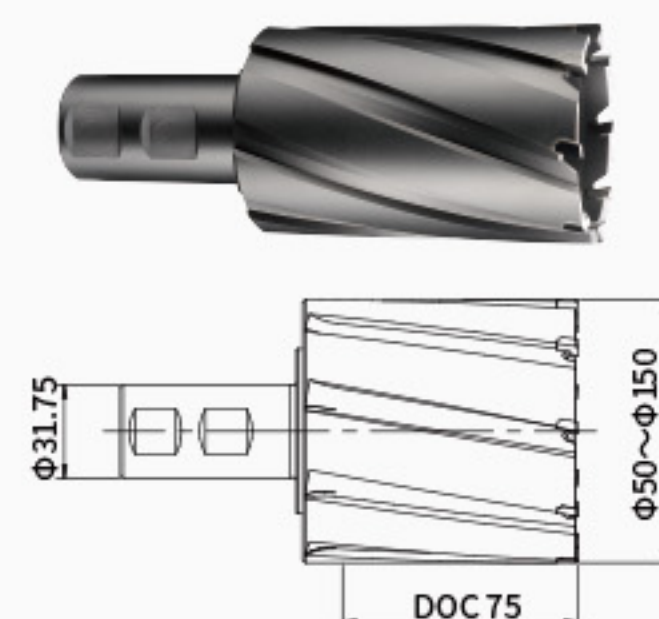

单位(Unit): mm

型号 MODEL	规格 SPECIFICATION	型号 MODEL	规格 SPECIFICATION	型号 MODEL	规格 SPECIFICATION	型号 MODEL	规格 SPECIFICATION
DNTJ-50500	50*75	DNTJ-50660	66*75	DNTJ-50820	82*75	DNTJ-50980	98*75
DNTJ-50510	51*75	DNTJ-50670	67*75	DNTJ-50830	83*75	DNTJ-50990	99*75
DNTJ-50520	52*75	DNTJ-50680	68*75	DNTJ-50840	84*75	DNTJ-51000	100*75
DNTJ-50530	53*75	DNTJ-50690	69*75	DNTJ-50850	85*75	DNTJ-51050	105*75
DNTJ-50540	54*75	DNTJ-50700	70*75	DNTJ-50860	86*75	DNTJ-51100	110*75
DNTJ-50550	55*75	DNTJ-50710	71*75	DNTJ-50870	87*75	DNTJ-51150	115*75
DNTJ-50560	56*75	DNTJ-50720	72*75	DNTJ-50880	88*75	DNTJ-51200	120*75
DNTJ-50570	57*75	DNTJ-50730	73*75	DNTJ-50890	89*75	DNTJ-51250	125*75
DNTJ-50580	58*75	DNTJ-50740	74*75	DNTJ-50900	90*75	DNTJ-51300	130*75
DNTJ-50590	59*75	DNTJ-50750	75*75	DNTJ-50910	91*75	DNTJ-51350	135*75
DNTJ-50600	60*75	DNTJ-50760	76*75	DNTJ-50920	92*75	DNTJ-51400	140*75
DNTJ-50610	61*75	DNTJ-50770	77*75	DNTJ-50930	93*75	DNTJ-51450	145*75
DNTJ-50620	62*75	DNTJ-50780	78*75	DNTJ-50940	94*75	DNTJ-51500	150*75
DNTJ-50630	63*75	DNTJ-50790	79*75	DNTJ-50950	95*75		
DNTJ-50640	64*75	DNTJ-50800	80*75	DNTJ-50960	96*75		
DNTJ-50650	65*75	DNTJ-50810	81*75	DNTJ-50970	97*75		

选配件 OPTIONAL ACCESSORIES

匹配顶针 MATCHING PILOT PIN				推荐钻机 RECOMMENDED MAGNETIC DRILLING MACHINE		
钻头直径 DIAMETER	型号 MODEL	规格 SPECIFICATION	顶针 PILOT PIN	钻头直径 DIAMETER	钻机型号 MAGNETIC DRILLING MACHING	匹配夹具 MATCHING TOOL HOLDER
50-150	DPB-C1192	12*192		50-150	DX-60	DJY-75X-MT3
					DX-120	DJY-75X-MT4

DNTJ

CARBIDE TIPPED ANNULAR CUTTER WITH J-TYPE WELDON SHANK 硬质合金J型削平柄钢板钻

- 削平柄型, 保证大规格钻孔时的夹持力与夹持精度, 适合直径50mm与以上规格;
- 专用硬质合金刀片, 分层及低摩擦力切削几何;
- 适合多种磁座钻机、钻床等设备上钻孔与环形槽加工;
- Parakkel shank ensures the clamping force and clamping accuracy when drilling large diameter, and it is suitable for the diameter of 50mm and above;
- Special carbide tips with layered and low friction cutting geometry;
- Applicable to drilling and process of annular groove on various magnetic drilling machines and press.



单位(Unit): mm

型号 MODEL	规格 SPECIFICATION	型号 MODEL	规格 SPECIFICATION	型号 MODEL	规格 SPECIFICATION	型号 MODEL	规格 SPECIFICATION
DNTJ-60500	50*100	DNTJ-60660	66*100	DNTJ-60820	82*100	DNTJ-60980	98*100
DNTJ-60510	51*100	DNTJ-60670	67*100	DNTJ-60830	83*100	DNTJ-60990	99*100
DNTJ-60520	52*100	DNTJ-60680	68*100	DNTJ-60840	84*100	DNTJ-61000	100*100
DNTJ-60530	53*100	DNTJ-60690	69*100	DNTJ-60850	85*100	DNTJ-61050	105*100
DNTJ-60540	54*100	DNTJ-60700	70*100	DNTJ-60860	86*100	DNTJ-61100	110*100
DNTJ-60550	55*100	DNTJ-60710	71*100	DNTJ-60870	87*100	DNTJ-61150	115*100
DNTJ-60560	56*100	DNTJ-60720	72*100	DNTJ-60880	88*100	DNTJ-61200	120*100
DNTJ-60570	57*100	DNTJ-60730	73*100	DNTJ-60890	89*100	DNTJ-61250	125*100
DNTJ-60580	58*100	DNTJ-60740	74*100	DNTJ-60900	90*100	DNTJ-61300	130*100
DNTJ-60590	59*100	DNTJ-60750	75*100	DNTJ-60910	91*100	DNTJ-61350	135*100
DNTJ-60600	60*100	DNTJ-60760	76*100	DNTJ-60920	92*100	DNTJ-61400	140*100
DNTJ-60610	61*100	DNTJ-60770	77*100	DNTJ-60930	93*100	DNTJ-61450	145*100
DNTJ-60620	62*100	DNTJ-60780	78*100	DNTJ-60940	94*100	DNTJ-61500	150*100
DNTJ-60630	63*100	DNTJ-60790	79*100	DNTJ-60950	95*100		
DNTJ-60640	64*100	DNTJ-60800	80*100	DNTJ-60960	96*100		
DNTJ-60650	65*100	DNTJ-60810	81*100	DNTJ-60970	97*100		

选配件 OPTIONAL ACCESSORIES

匹配顶针 MATCHING PILOT PIN				推荐钻机 RECOMMENDED MAGNETIC DRILLING MACHINE		
钻头直径 DIAMETER	型号 MODEL	规格 SPECIFICATION	顶针 PILOT PIN	钻头直径 DIAMETER	钻机型号 MAGNETIC DRILLING MACHING	匹配夹具 MATCHING TOOL HOLDER
50-150	DPB-C1212	12*212		50-150	DX-120	DJJY-100X-MT4