

DNTK CARBIDE TIPPED ANNULAR CUTTER WITH K-TYPE WELDON SHANK 硬质合金K型直角柄钢板钻

- 单孔直角柄型, 有稳固的夹持力, 更好的保证钻孔稳定性与钻孔精度, 同时也能适合单粒快速夹具夹持;
- 专用硬质合金刀片, 分层及低摩擦力切削几何;
- 适合多种磁座钻机、钻床等设备上钻孔与环形槽加工;
- Weldon shank+1 additional hole, with more stable clamping force, better stability for drilling and better precision of holes. Suitable for quick-change arbor with one ball;
- Special carbide tips with layered and low friction cutting geometry;
- Applicable to drilling and process of annular groove on various magnetic drilling machines and press.

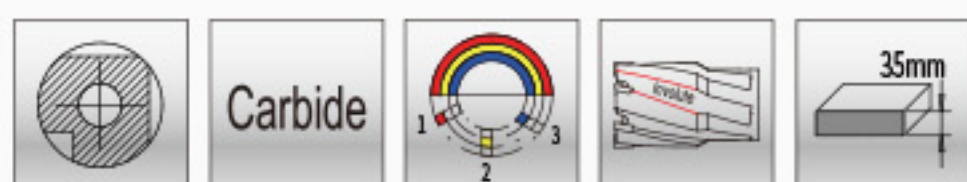
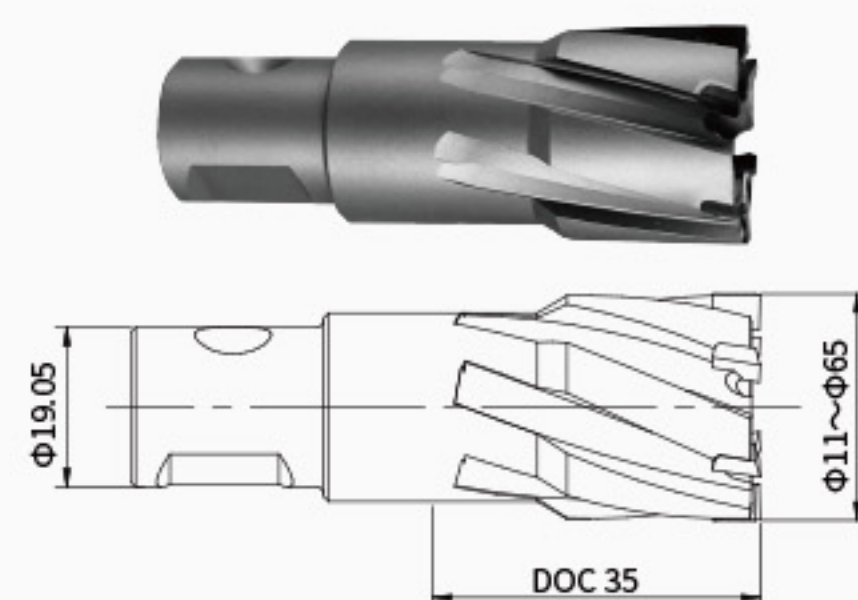

单位(Unit): mm

型号 MODEL	规格 SPECIFICATION	型号 MODEL	规格 SPECIFICATION	型号 MODEL	规格 SPECIFICATION	型号 MODEL	规格 SPECIFICATION
DNTK-30110	11*35	DNTK-30245	24.5*35	DNTK-30410	41*35	DNTK-30590	59*35
DNTK-30120	12*35	DNTK-30250	25*35	DNTK-30420	42*35	DNTK-30600	60*35
DNTK-30130	13*35	DNTK-30260	26*35	DNTK-30430	43*35	DNTK-30610	61*35
DNTK-30140	14*35	DNTK-30265	26.5*35	DNTK-30440	44*35	DNTK-30620	62*35
DNTK-30150	15*35	DNTK-30270	27*35	DNTK-30450	45*35	DNTK-30630	63*35
DNTK-30160	16*35	DNTK-30280	28*35	DNTK-30460	46*35	DNTK-30640	64*35
DNTK-30170	17*35	DNTK-30290	29*35	DNTK-30470	47*35	DNTK-30650	65*35
DNTK-30180	18*35	DNTK-30300	30*35	DNTK-30480	48*35		
DNTK-30185	18.5*35	DNTK-30310	31*35	DNTK-30490	49*35		
DNTK-30190	19*35	DNTK-30320	32*35	DNTK-30500	50*35		
DNTK-30200	20*35	DNTK-30330	33*35	DNTK-30510	51*35		
DNTK-30205	20.5*35	DNTK-30340	34*35	DNTK-30520	52*35		
DNTK-30210	21*35	DNTK-30350	35*35	DNTK-30530	53*35		
DNTK-30215	21.5*35	DNTK-30360	36*35	DNTK-30540	54*35		
DNTK-30220	22*35	DNTK-30370	37*35	DNTK-30550	55*35		
DNTK-30225	22.5*35	DNTK-30380	38*35	DNTK-30560	56*35		
DNTK-30230	23*35	DNTK-30390	39*35	DNTK-30570	57*35		
DNTK-30240	24*35	DNTK-30400	40*35	DNTK-30580	58*35		

英制规格详见P495 INCH SIZE ON P495

选配件 OPTIONAL ACCESSORIES

匹配顶针 MATCHING PILOT PIN				推荐钻机 RECOMMENDED MAGNETIC DRILLING MACHINE		
钻头直径 DIAMETER	型号 MODEL	规格 SPECIFICATION	顶针 PILOT PIN	钻头直径 DIAMETER	钻机型号 MAGNETIC DRILLING MACHING	匹配夹具 MATCHING TOOL HOLDER
11	DPB-42090	4.75*90		11	DX-35	—
12-17	DPB-62090	6.34*90		12-17	DX-35	—
18-65	DPB-81090	7.98*90			DX-35	—
					DX-60	DJXY-50D-MT3
					DX-120	DJXY-50X-MT4

DNTK CARBIDE TIPPED ANNULAR CUTTER WITH K-TYPE WELDON SHANK 硬质合金K型直角柄钢板钻

- 单孔直角柄型, 有稳固的夹持力, 更好的保证钻孔稳定性与钻孔精度, 同时也能适合单粒快速夹具夹持;
- 专用硬质合金刀片, 分层及低摩擦力切削几何;
- 适合多种磁座钻机、钻床等设备上钻孔与环形槽加工;
- Weldon shank+1 additional hole, with more stable clamping force, better stability for drilling and better precision of holes. Suitable for quick-change arbor with one ball;
- Special carbide tips with layered and low friction cutting geometry;
- Applicable to drilling and process of annular groove on various magnetic drilling machines and press.

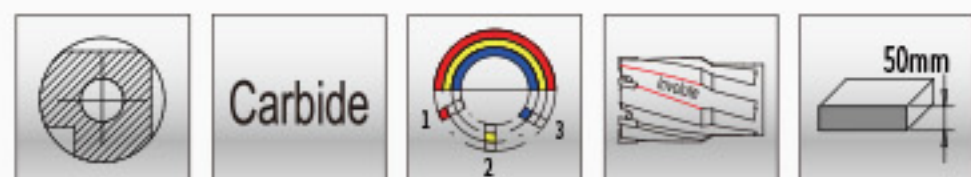
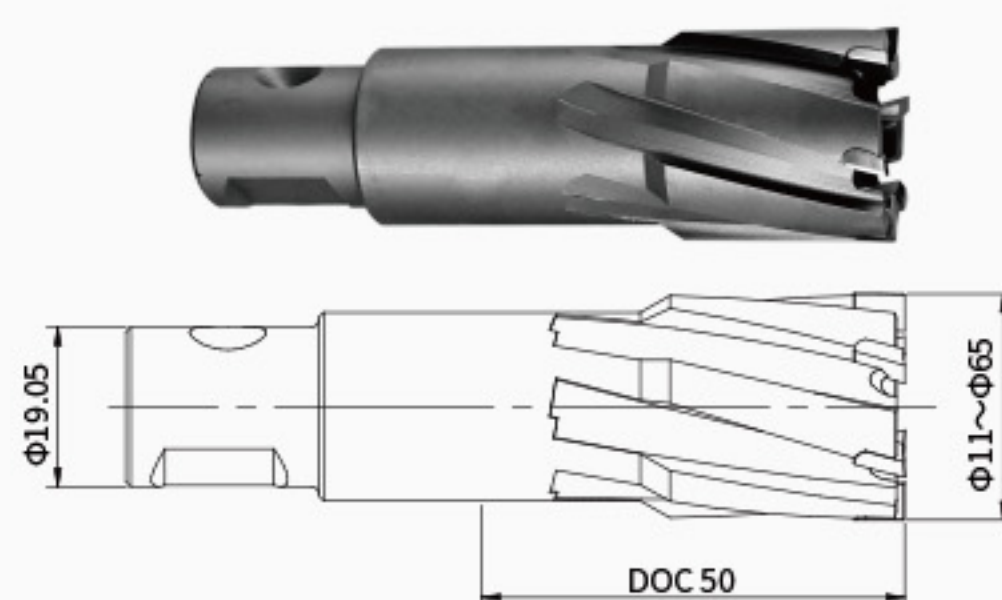

单位(Unit): mm

型号 MODEL	规格 SPECIFICATION	型号 MODEL	规格 SPECIFICATION	型号 MODEL	规格 SPECIFICATION	型号 MODEL	规格 SPECIFICATION
DNTK-40110	11*50	DNTK-40245	24.5*50	DNTK-40410	41*50	DNTK-40590	59*50
DNTK-40120	12*50	DNTK-40250	25*50	DNTK-40420	42*50	DNTK-40600	60*50
DNTK-40130	13*50	DNTK-40260	26*50	DNTK-40430	43*50	DNTK-40610	61*50
DNTK-40140	14*50	DNTK-40265	26.5*50	DNTK-40440	44*50	DNTK-40620	62*50
DNTK-40150	15*50	DNTK-40270	27*50	DNTK-40450	45*50	DNTK-40630	63*50
DNTK-40160	16*50	DNTK-40280	28*50	DNTK-40460	46*50	DNTK-40640	64*50
DNTK-40170	17*50	DNTK-40290	29*50	DNTK-40470	47*50	DNTK-40650	65*50
DNTK-40180	18*50	DNTK-40300	30*50	DNTK-40480	48*50		
DNTK-40185	18.5*50	DNTK-40310	31*50	DNTK-40490	49*50		
DNTK-40190	19*50	DNTK-40320	32*50	DNTK-40500	50*50		
DNTK-40200	20*50	DNTK-40330	33*50	DNTK-40510	51*50		
DNTK-40205	20.5*50	DNTK-40340	34*50	DNTK-40520	52*50		
DNTK-40210	21*50	DNTK-40350	35*50	DNTK-40530	53*50		
DNTK-40215	21.5*50	DNTK-40360	36*50	DNTK-40540	54*50		
DNTK-40220	22*50	DNTK-40370	37*50	DNTK-40550	55*50		
DNTK-40225	22.5*50	DNTK-40380	38*50	DNTK-40560	56*50		
DNTK-40230	23*50	DNTK-40390	39*50	DNTK-40570	57*50		
DNTK-40240	24*50	DNTK-40400	40*50	DNTK-40580	58*50		

英制规格详见P496 INCH SIZE ON P496

选配件 OPTIONAL ACCESSORIES

匹配顶针 MATCHING PILOT PIN				推荐钻机 RECOMMENDED MAGNETIC DRILLING MACHINE		
钻头直径 DIAMETER	型号 MODEL	规格 SPECIFICATION	顶针 PILOT PIN	钻头直径 DIAMETER	钻机型号 MAGNETIC DRILLING MACHING	匹配夹具 MATCHING TOOL HOLDER
11	DPB-42102	4.75*102		11	DX-35	—
12-17	DPB-62102	6.34*102		12-17	DX-35	—
18-65	DPB-81103	7.98*103			DX-35	—
					DX-60	DJXY-50D-MT3
					DX-120	DJXY-50X-MT4

DNTK CARBIDE TIPPED ANNULAR CUTTER WITH K-TYPE WELDON SHANK 硬质合金K型直角柄钢板钻

- 单孔直角柄型, 有稳固的夹持力, 更好的保证钻孔稳定性与钻孔精度, 同时也能适合单粒快速夹具夹持;
- 专用硬质合金刀片, 分层及低摩擦力切削几何;
- 适合多种磁座钻机、钻床等设备上钻孔与环形槽加工;
- Weldon shank+1 additional hole, with more stable clamping force, better stability for drilling and better precision of holes. Suitable for quick-change arbor with one ball;
- Special carbide tips with layered and low friction cutting geometry;
- Applicable to drilling and process of annular groove on various magnetic drilling machines and press.

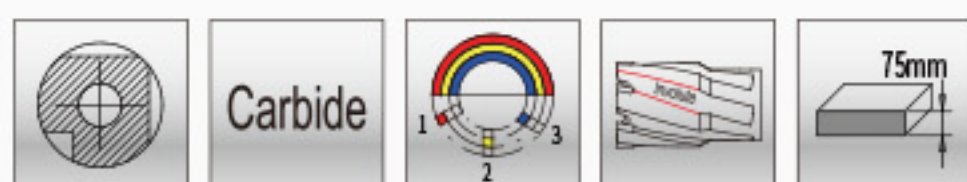
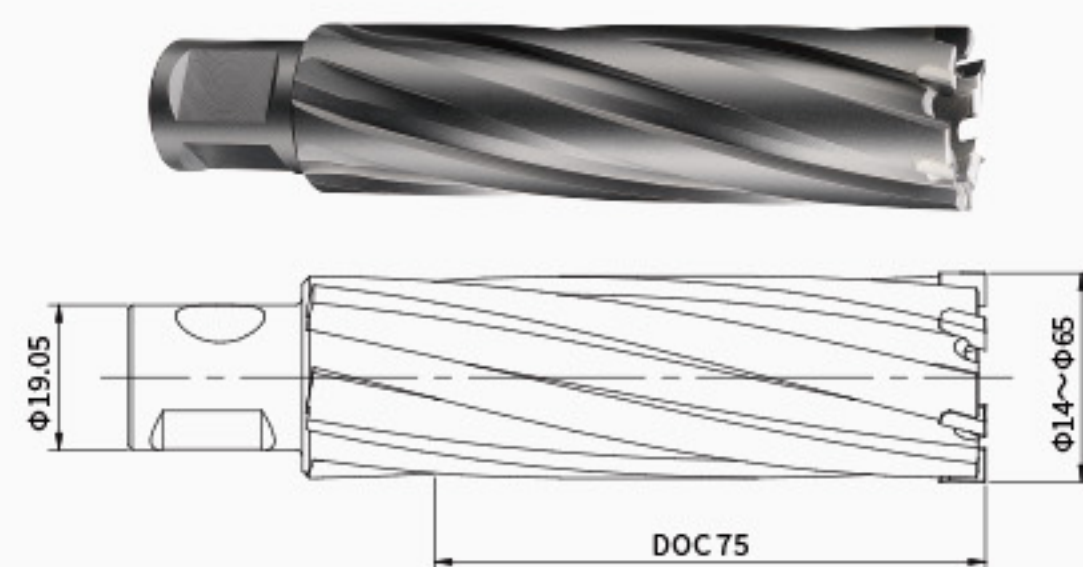

单位(Unit): mm

型号 MODEL	规格 SPECIFICATION	型号 MODEL	规格 SPECIFICATION	型号 MODEL	规格 SPECIFICATION	型号 MODEL	规格 SPECIFICATION
DNTK-50140	14*75	DNTK-50270	27*75	DNTK-50400	40*75	DNTK-50530	53*75
DNTK-50150	15*75	DNTK-50280	28*75	DNTK-50410	41*75	DNTK-50540	54*75
DNTK-50160	16*75	DNTK-50290	29*75	DNTK-50420	42*75	DNTK-50550	55*75
DNTK-50170	17*75	DNTK-50300	30*75	DNTK-50430	43*75	DNTK-50560	56*75
DNTK-50180	18*75	DNTK-50310	31*75	DNTK-50440	44*75	DNTK-50570	57*75
DNTK-50190	19*75	DNTK-50320	32*75	DNTK-50450	45*75	DNTK-50580	58*75
DNTK-50200	20*75	DNTK-50330	33*75	DNTK-50460	46*75	DNTK-50590	59*75
DNTK-50210	21*75	DNTK-50340	34*75	DNTK-50470	47*75	DNTK-50600	60*75
DNTK-50220	22*75	DNTK-50350	35*75	DNTK-50480	48*75	DNTK-50610	61*75
DNTK-50230	23*75	DNTK-50360	36*75	DNTK-50490	49*75	DNTK-50620	62*75
DNTK-50240	24*75	DNTK-50370	37*75	DNTK-50500	50*75	DNTK-50630	63*75
DNTK-50250	25*75	DNTK-50380	38*75	DNTK-50510	51*75	DNTK-50640	64*75
DNTK-50260	26*75	DNTK-50390	39*75	DNTK-50520	52*75	DNTK-50650	65*75

选配件 OPTIONAL ACCESSORIES

匹配顶针 MATCHING PILOT PIN				推荐钻机 RECOMMENDED MAGNETIC DRILLING MACHINE		
钻头直径 DIAMETER	型号 MODEL	规格 SPECIFICATION	顶针 PILOT PIN	钻头直径 DIAMETER	钻机型号 MAGNETIC DRILLING MACHING	匹配夹具 MATCHING TOOL HOLDER
14-17	DPB-62130	6.34*130		14-17	DX-60	DJXY-75X-MT3
18-65	DPB-81130	7.98*130		18-65	DX-60	DJXY-75X-MT3
				18-65	DX-120	DJXY-75X-MT4

DNTK CARBIDE TIPPED ANNULAR CUTTER WITH K-TYPE WELDON SHANK 硬质合金K型直角柄钢板钻

- 单孔直角柄型, 有稳固的夹持力, 更好的保证钻孔稳定性与钻孔精度, 同时也能适合单粒快速夹具夹持;
- 专用硬质合金刀片, 分层及低摩擦力切削几何;
- 适合多种磁座钻机、钻床等设备上钻孔与环形槽加工;
- Weldon shank+1 additional hole, with more stable clamping force, better stability for drilling and better precision of holes. Suitable for quick-change arbor with one ball;
- Special carbide tips with layered and low friction cutting geometry;
- Applicable to drilling and process of annular groove on various magnetic drilling machines and press.

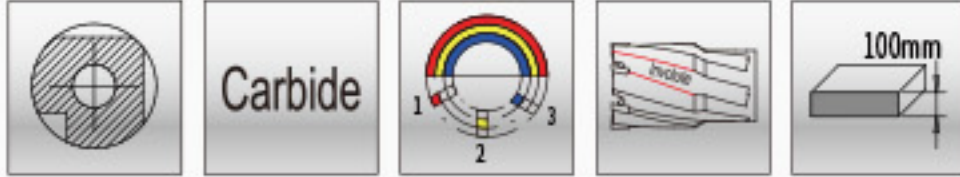
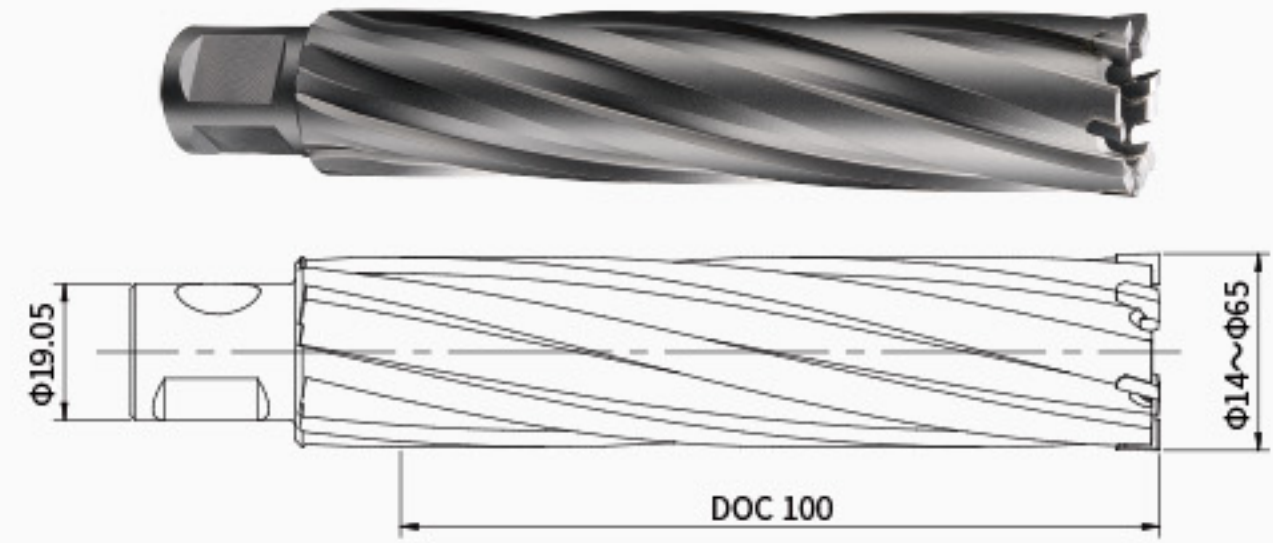

单位(Unit): mm

型号 MODEL	规格 SPECIFICATION	型号 MODEL	规格 SPECIFICATION	型号 MODEL	规格 SPECIFICATION	型号 MODEL	规格 SPECIFICATION
DNTK-60140	14*100	DNTK-60270	27*100	DNTK-60400	40*100	DNTK-60530	53*100
DNTK-60150	15*100	DNTK-60280	28*100	DNTK-60410	41*100	DNTK-60540	54*100
DNTK-60160	16*100	DNTK-60290	29*100	DNTK-60420	42*100	DNTK-60550	55*100
DNTK-60170	17*100	DNTK-60300	30*100	DNTK-60430	43*100	DNTK-60560	56*100
DNTK-60180	18*100	DNTK-60310	31*100	DNTK-60440	44*100	DNTK-60570	57*100
DNTK-60190	19*100	DNTK-60320	32*100	DNTK-60450	45*100	DNTK-60580	58*100
DNTK-60200	20*100	DNTK-60330	33*100	DNTK-60460	46*100	DNTK-60590	59*100
DNTK-60210	21*100	DNTK-60340	34*100	DNTK-60470	47*100	DNTK-60600	60*100
DNTK-60220	22*100	DNTK-60350	35*100	DNTK-60480	48*100	DNTK-60610	61*100
DNTK-60230	23*100	DNTK-60360	36*100	DNTK-60490	49*100	DNTK-60620	62*100
DNTK-60240	24*100	DNTK-60370	37*100	DNTK-60500	50*100	DNTK-60630	63*100
DNTK-60250	25*100	DNTK-60380	38*100	DNTK-60510	51*100	DNTK-60640	64*100
DNTK-60260	26*100	DNTK-60390	39*100	DNTK-60520	52*100	DNTK-60650	65*100



选配件 OPTIONAL ACCESSORIES

匹配顶针 MATCHING PILOT PIN				推荐钻机 RECOMMENDED MAGNETIC DRILLING MACHINE		
钻头直径 DIAMETER	型号 MODEL	规格 SPECIFICATION	顶针 PILOT PIN	钻头直径 DIAMETER	钻机型号 MAGNETIC DRILLING MACHING	匹配夹具 MATCHING TOOL HOLDER
14-17	DPB-62160	6.34*160		14-17	DX-120	DJXY-100X-MT4
18-65	DPB-81160	7.98*160		18-65		

DNTK CARBIDE TIPPED ANNULAR CUTTER WITH K-TYPE WELDON SHANK 硬质合金K型直角柄钢板钻

- 单孔直角柄型, 有稳固的夹持力, 更好的保证钻孔稳定性与钻孔精度, 同时也能适合单粒快速夹具夹持;
- 专用硬质合金刀片, 分层及低摩擦力切削几何;
- 适合多种磁座钻机、钻床等设备上钻孔与环形槽加工;
- Weldon shank+1 additional hole, with more stable clamping force, better stability for drilling and better precision of holes. Suitable for quick-change arbor with one ball;
- Special carbide tips with layered and low friction cutting geometry;
- Applicable to drilling and process of annular groove on various magnetic drilling machines and press.

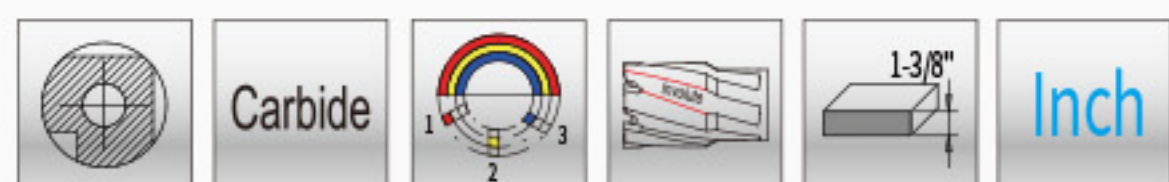
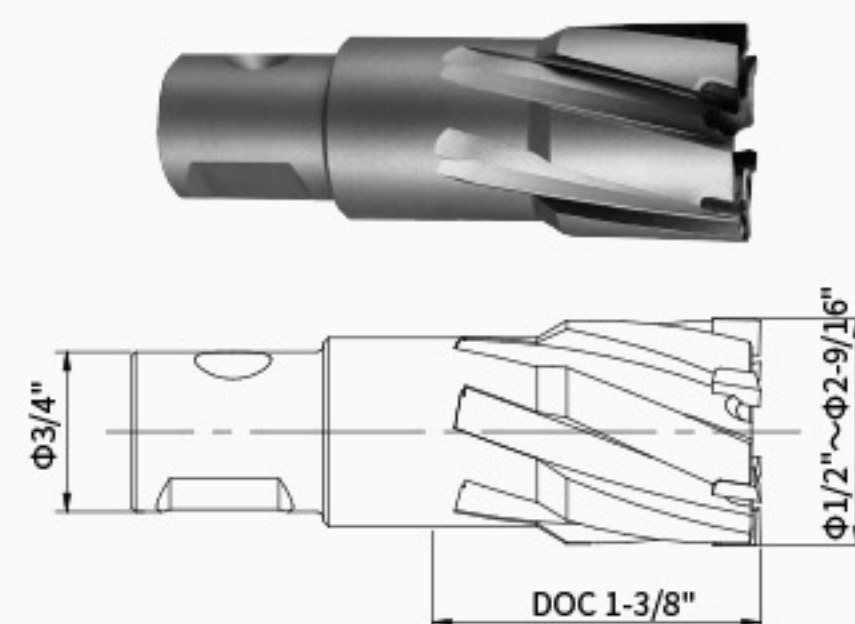

单位(Unit): inch

型号 MODEL	规格 SPECIFICATION	型号 MODEL	规格 SPECIFICATION	型号 MODEL	规格 SPECIFICATION	型号 MODEL	规格 SPECIFICATION
DNTK-C0500	1/2"×1-3/8"	DNTK-C1062	1-1/16"×1-3/8"	DNTK-C1625	1-5/8"×1-3/8"	DNTK-C2187	2-3/16"×1-3/8"
DNTK-C0562	9/16"×1-3/8"	DNTK-C1125	1-1/8"×1-3/8"	DNTK-C1687	1-11/16"×1-3/8"	DNTK-C2250	2-1/4"×1-3/8"
DNTK-C0625	5/8"×1-3/8"	DNTK-C1187	1-3/16"×1-3/8"	DNTK-C1750	1-3/4"×1-3/8"	DNTK-C2312	2-5/16"×1-3/8"
DNTK-C0687	11/16"×1-3/8"	DNTK-C1250	1-1/4"×1-3/8"	DNTK-C1812	1-13/16"×1-3/8"	DNTK-C2375	2-3/8"×1-3/8"
DNTK-C0750	3/4"×1-3/8"	DNTK-C1312	1-5/16"×1-3/8"	DNTK-C1875	1-7/8"×1-3/8"	DNTK-C2437	2-7/16"×1-3/8"
DNTK-C0812	13/16"×1-3/8"	DNTK-C1375	1-3/8"×1-3/8"	DNTK-C1937	1-15/16"×1-3/8"	DNTK-C2500	2-1/2"×1-3/8"
DNTK-C0875	7/8"×1-3/8"	DNTK-C1437	1-7/16"×1-3/8"	DNTK-C2000	2"×1-3/8"	DNTK-C2562	2-9/16"×1-3/8"
DNTK-C0937	15/16"×1-3/8"	DNTK-C1500	1-1/2"×1-3/8"	DNTK-C2062	2-1/16"×1-3/8"		
DNTK-C1000	1"×1-3/8"	DNTK-C1562	1-9/16"×1-3/8"	DNTK-C2125	2-1/8"×1-3/8"		

公制规格详见P465 METRIC SIZE ON P465

选配件 OPTIONAL ACCESSORIES

匹配顶针 MATCHING PILOT PIN				推荐钻机 RECOMMENDED MAGNETIC DRILLING MACHINE		
钻头直径 DIAMETER	型号 MODEL	规格 SPECIFICATION	顶针 PILOT PIN	钻头直径 DIAMETER	钻机型号 MAGNETIC DRILLING MACHINE	匹配夹具 MATCHING TOOL HOLDER
1/2"-11/16"	DPB-62090	6.34*90		1/2"-11/16"	DX-35	—
3/4"-2-9/16"	DPB-81090	7.98*90		3/4"-2-9/16"	DX-35	—
				DX-60	DJXY-50D-MT3	
				DX-120	DJXY-50X-MT4	

DNTK CARBIDE TIPPED ANNULAR CUTTER WITH K-TYPE WELDON SHANK 硬质合金K型直角柄钢板钻

- 单孔直角柄型, 有稳固的夹持力, 更好的保证钻孔稳定性与钻孔精度, 同时也能适合单粒快速夹具夹持;
- 专用硬质合金刀片, 分层及低摩擦力切削几何;
- 适合多种磁座钻机、钻床等设备上钻孔与环形槽加工;
- Weldon shank+1 additional hole, with more stable clamping force, better stability for drilling and better precision of holes. Suitable for quick-change arbor with one ball;
- Special carbide tips with layered and low friction cutting geometry;
- Applicable to drilling and process of annular groove on various magnetic drilling machines and press.

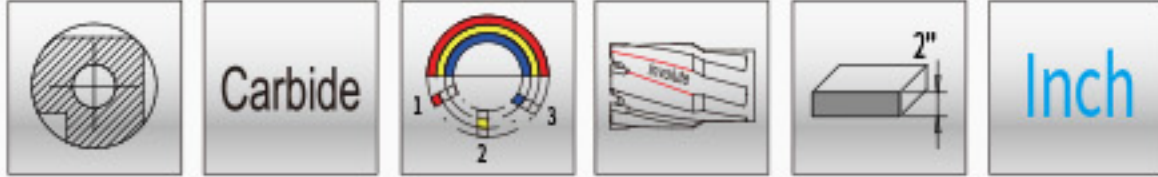
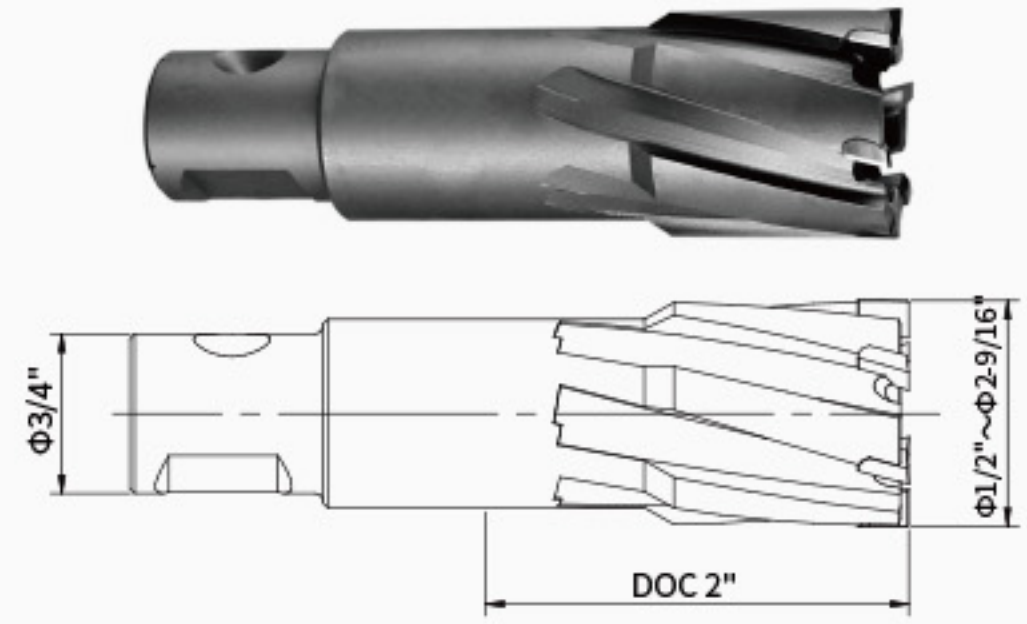

单位(Unit): inch

型号 MODEL	规格 SPECIFICATION	型号 MODEL	规格 SPECIFICATION	型号 MODEL	规格 SPECIFICATION	型号 MODEL	规格 SPECIFICATION
DNTK-D0500	1/2"*2"	DNTK-D1062	1-1/16"*2"	DNTK-D1625	1-5/8"*2"	DNTK-D2187	2-3/16"*2"
DNTK-D0562	9/16"*2"	DNTK-D1125	1-1/8"*2"	DNTK-D1687	1-11/16"*2"	DNTK-D2250	2-1/4"*2"
DNTK-D0625	5/8"*2"	DNTK-D1187	1-3/16"*2"	DNTK-D1750	1-3/4"*2"	DNTK-D2312	2-5/16"*2"
DNTK-D0687	11/16"*2"	DNTK-D1250	1-1/4"*2"	DNTK-D1812	1-13/16"*2"	DNTK-D2375	2-3/8"*2"
DNTK-D0750	3/4"*2"	DNTK-D1312	1-5/16"*2"	DNTK-D1875	1-7/8"*2"	DNTK-D2437	2-7/16"*2"
DNTK-D0812	13/16"*2"	DNTK-D1375	1-3/8"*2"	DNTK-D1937	1-15/16"*2"	DNTK-D2500	2-1/2"*2"
DNTK-D0875	7/8"*2"	DNTK-D1437	1-7/16"*2"	DNTK-D2000	2"*2"	DNTK-D2562	2-9/16"*2"
DNTK-D0937	15/16"*2"	DNTK-D1500	1-1/2"*2"	DNTK-D2062	2-1/16"*2"		
DNTK-D1000	1"*2"	DNTK-D1562	1-9/16"*2"	DNTK-D2125	2-1/8"*2"		

公制规格详见P466 METRIC SIZE ON P466

选配件 OPTIONAL ACCESSORIES

匹配顶针 MATCHING PILOT PIN				推荐钻机 RECOMMENDED MAGNETIC DRILLING MACHINE		
钻头直径 DIAMETER	型号 MODEL	规格 SPECIFICATION	顶针 PILOT PIN	钻头直径 DIAMETER	钻机型号 MAGNETIC DRILLING MACHING	匹配夹具 MATCHING TOOL HOLDER
1/2"-11/16"	DPB-62102	6.34*102		1/2"-11/16"	DX-35	—
3/4"-2-9/16"	DPB-81103	7.98*103		3/4"-2-9/16"	DX-35	—
				DX-60	DJXY-50D-MT3	
				DX-120	DJXY-50X-MT4	