

DNTL CARBIDE TIPPED ANNULAR CUTTER WITH L-TYPE THREAD SHANK 硬质合金L型螺纹柄钢板钻

- 螺纹柄型, 适合专用钻机接口;
- 专用硬质合金刀片, 分层及低摩擦力切削几何;
- Thread shank. Suitable for special purpose magnetic drilling machines;
- Special carbide tips with layered and low friction cutting geometry.

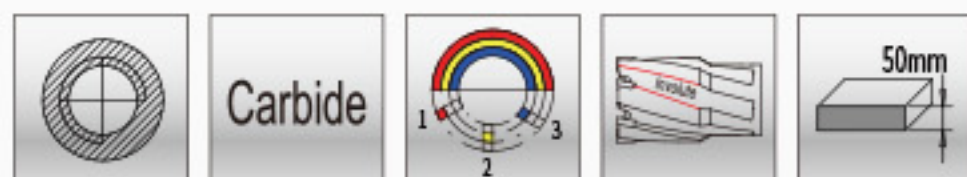
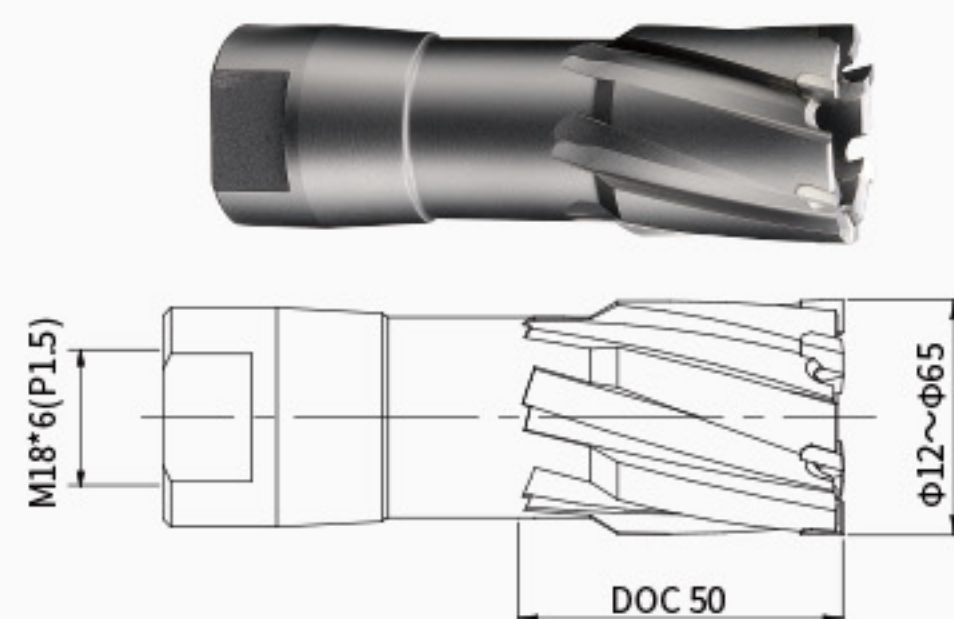

单位(Unit): mm

型号 MODEL	规格 SPECIFICATION	型号 MODEL	规格 SPECIFICATION	型号 MODEL	规格 SPECIFICATION	型号 MODEL	规格 SPECIFICATION
DNTL-40120	12*50	DNTL-40260	26*50	DNTL-40400	40*50	DNTL-40540	54*50
DNTL-40130	13*50	DNTL-40270	27*50	DNTL-40410	41*50	DNTL-40550	55*50
DNTL-40140	14*50	DNTL-40280	28*50	DNTL-40420	42*50	DNTL-40560	56*50
DNTL-40150	15*50	DNTL-40290	29*50	DNTL-40430	43*50	DNTL-40570	57*50
DNTL-40160	16*50	DNTL-40300	30*50	DNTL-40440	44*50	DNTL-40580	58*50
DNTL-40170	17*50	DNTL-40310	31*50	DNTL-40450	45*50	DNTL-40590	59*50
DNTL-40180	18*50	DNTL-40320	32*50	DNTL-40460	46*50	DNTL-40600	60*50
DNTL-40190	19*50	DNTL-40330	33*50	DNTL-40470	47*50	DNTL-40610	61*50
DNTL-40200	20*50	DNTL-40340	34*50	DNTL-40480	48*50	DNTL-40620	62*50
DNTL-40210	21*50	DNTL-40350	35*50	DNTL-40490	49*50	DNTL-40630	63*50
DNTL-40220	22*50	DNTL-40360	36*50	DNTL-40500	50*50	DNTL-40640	64*50
DNTL-40230	23*50	DNTL-40370	37*50	DNTL-40510	51*50	DNTL-40650	65*50
DNTL-40240	24*50	DNTL-40380	38*50	DNTL-40520	52*50		
DNTL-40250	25*50	DNTL-40390	39*50	DNTL-40530	53*50		

选配件 OPTIONAL ACCESSORIES

匹配夹具 MATCHING TOOL HOLDER			
钻头直径 DIAMETER	型号 MODEL	规格 SPECIFICATION	夹具 TOOL HOLDER
12-65	DJLY-50K-MT2	MT2*50*M18 ×6(P1.5)	