

DNTP CARBIDE TIPPED ANNULAR CUTTER WITH P-TYPE WELDON SHANK 硬质合金P型直角柄钢板钻

- 直角柄型, 保证大规格钻孔时的夹持力与夹持精度, 适合直径61mm与以上规格;
- 专用硬质合金刀片, 分层及低摩擦力切削几何;
- 适合多种磁座钻机、钻床等设备上钻孔与环形槽加工;
- Weldon shank ensures the clamping force and clamping accuracy when drilling large diameter, and it is suitable for the diameter of 61mm and above;
- Special carbide tips with layered and low friction cutting geometry;
- Applicable to drilling and process of annular groove on various magnetic drilling machines and press.

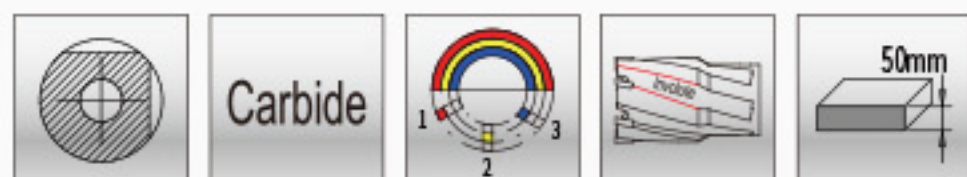
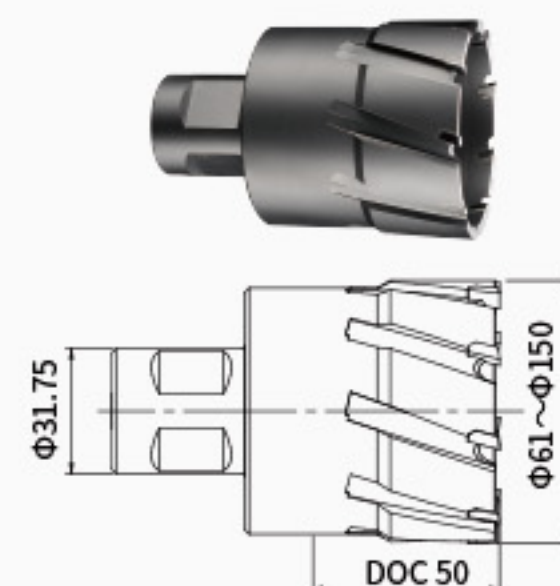

单位(Unit): mm

型号 MODEL	规格 SPECIFICATION	型号 MODEL	规格 SPECIFICATION	型号 MODEL	规格 SPECIFICATION	型号 MODEL	规格 SPECIFICATION
DNTP-40610	61*50	DNTP-40780	78*50	DNTP-40950	95*50	DNTP-41200	120*50
DNTP-40620	62*50	DNTP-40790	79*50	DNTP-40960	96*50	DNTP-41250	125*50
DNTP-40630	63*50	DNTP-40800	80*50	DNTP-40970	97*50	DNTP-41300	130*50
DNTP-40640	64*50	DNTP-40810	81*50	DNTP-40980	98*50	DNTP-41350	135*50
DNTP-40650	65*50	DNTP-40820	82*50	DNTP-40990	99*50	DNTP-41380	138*50
DNTP-40660	66*50	DNTP-40830	83*50	DNTP-41000	100*50	DNTP-41400	140*50
DNTP-40670	67*50	DNTP-40840	84*50	DNTP-41010	101*50	DNTP-41450	145*50
DNTP-40680	68*50	DNTP-40850	85*50	DNTP-41020	102*50	DNTP-41500	150*50
DNTP-40690	69*50	DNTP-40860	86*50	DNTP-41030	103*50		
DNTP-40700	70*50	DNTP-40870	87*50	DNTP-41040	104*50		
DNTP-40710	71*50	DNTP-40880	88*50	DNTP-41050	105*50		
DNTP-40720	72*50	DNTP-40890	89*50	DNTP-41060	106*50		
DNTP-40730	73*50	DNTP-40900	90*50	DNTP-41070	107*50		
DNTP-40740	74*50	DNTP-40910	91*50	DNTP-41080	108*50		
DNTP-40750	75*50	DNTP-40920	92*50	DNTP-41090	109*50		
DNTP-40760	76*50	DNTP-40930	93*50	DNTP-41100	110*50		
DNTP-40770	77*50	DNTP-40940	94*50	DNTP-41150	115*50		

英制规格详见P497 INCH SIZE ON P497

选配件 OPTIONAL ACCESSORIES

匹配顶针 MATCHING PILOT PIN				推荐钻机 RECOMMENDED MAGNETIC DRILLING MACHINE		
钻头直径 DIAMETER	型号 MODEL	规格 SPECIFICATION	顶针 PILOT PIN	钻头直径 DIAMETER	钻机型号 MAGNETIC DRILLING MACHINE	匹配夹具 MATCHING TOOL HOLDER
61-150	DPB-81115	7.98*115		61-150	DX-120	DJPY-50X-MT4

DNTP CARBIDE TIPPED ANNULAR CUTTER WITH P-TYPE WELDON SHANK 硬质合金P型直角柄钢板钻

- 直角柄型, 保证大规格钻孔时的夹持力与夹持精度, 适合直径61mm与以上规格;
- 专用硬质合金刀片, 分层及低摩擦力切削几何;
- 适合多种磁座钻机、钻床等设备上钻孔与环形槽加工;
- Weldon shank ensures the clamping force and clamping accuracy when drilling large diameter, and it is suitable for the diameter of 61mm and above;
- Special carbide tips with layered and low friction cutting geometry;
- Applicable to drilling and process of annular groove on various magnetic drilling machines and press.

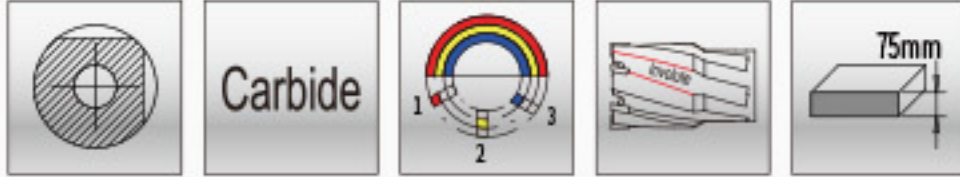
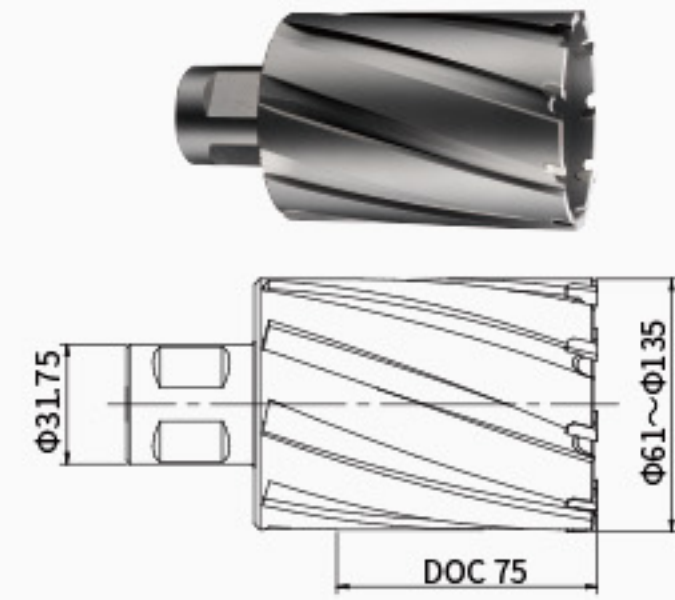

单位(Unit): mm

型号 MODEL	规格 SPECIFICATION	型号 MODEL	规格 SPECIFICATION	型号 MODEL	规格 SPECIFICATION	型号 MODEL	规格 SPECIFICATION
DNTP-50610	61*75	DNTP-50740	74*75	DNTP-50870	87*75	DNTP-51000	100*75
DNTP-50620	62*75	DNTP-50750	75*75	DNTP-50880	88*75	DNTP-51050	105*75
DNTP-50630	63*75	DNTP-50760	76*75	DNTP-50890	89*75	DNTP-51100	110*75
DNTP-50640	64*75	DNTP-50770	77*75	DNTP-50900	90*75	DNTP-51150	115*75
DNTP-50650	65*75	DNTP-50780	78*75	DNTP-50910	91*75	DNTP-51200	120*75
DNTP-50660	66*75	DNTP-50790	79*75	DNTP-50920	92*75	DNTP-51250	125*75
DNTP-50670	67*75	DNTP-50800	80*75	DNTP-50930	93*75	DNTP-51300	130*75
DNTP-50680	68*75	DNTP-50810	81*75	DNTP-50940	94*75	DNTP-51350	135*75
DNTP-50690	69*75	DNTP-50820	82*75	DNTP-50950	95*75		
DNTP-50700	70*75	DNTP-50830	83*75	DNTP-50960	96*75		
DNTP-50710	71*75	DNTP-50840	84*75	DNTP-50970	97*75		
DNTP-50720	72*75	DNTP-50850	85*75	DNTP-50980	98*75		
DNTP-50730	73*75	DNTP-50860	86*75	DNTP-50990	99*75		

英制规格详见P498 INCH SIZE ON P498

选配件 OPTIONAL ACCESSORIES

匹配顶针 MATCHING PILOT PIN				推荐钻机 RECOMMENDED MAGNETIC DRILLING MACHINE		
钻头直径 DIAMETER	型号 MODEL	规格 SPECIFICATION	顶针 PILOT PIN	钻头直径 DIAMETER	钻机型号 MAGNETIC DRILLING MACHING	匹配夹具 MATCHING TOOL HOLDER
61-135	DPB-81145	7.98*145		61-135	DX-120	DJPY-75X-MT4

DNTP CARBIDE TIPPED ANNULAR CUTTER WITH P-TYPE WELDON SHANK 硬质合金P型直角柄钢板钻

- 直角柄型, 保证大规格钻孔时的夹持力与夹持精度, 适合直径61mm与以上规格;
- 专用硬质合金刀片, 分层及低摩擦力切削几何;
- 适合多种磁座钻机、钻床等设备上钻孔与环形槽加工;
- Weldon shank ensures the clamping force and clamping accuracy when drilling large diameter, and it is suitable for the diameter of 61mm and above;
- Special carbide tips with layered and low friction cutting geometry;
- Applicable to drilling and process of annular groove on various magnetic drilling machines and press.

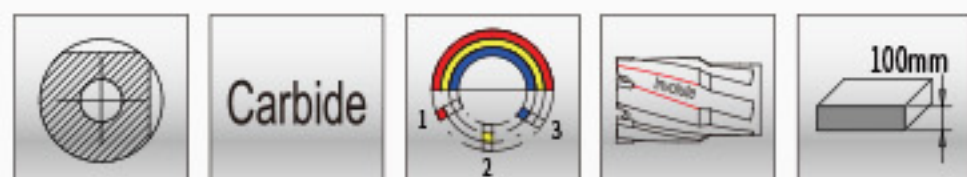
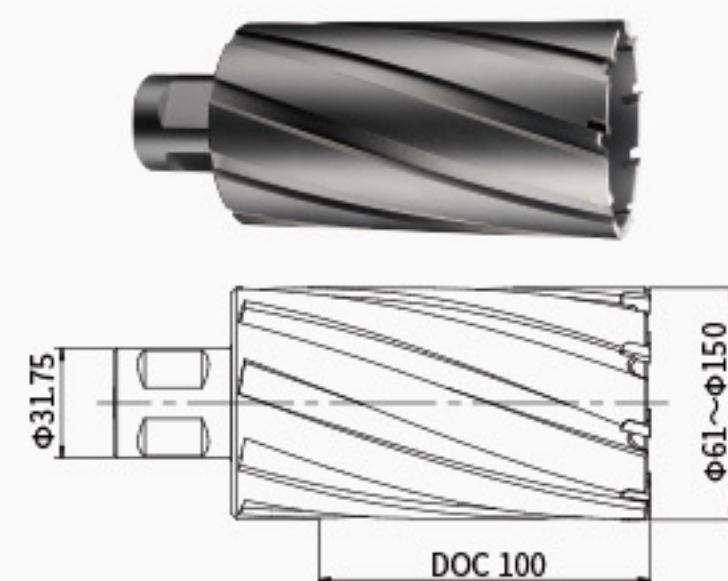

单位(Unit): mm

型号 MODEL	规格 SPECIFICATION	型号 MODEL	规格 SPECIFICATION	型号 MODEL	规格 SPECIFICATION	型号 MODEL	规格 SPECIFICATION
DNTP-60610	61*100	DNTP-60750	75*100	DNTP-60890	89*100	DNTP-61150	115*100
DNTP-60620	62*100	DNTP-60760	76*100	DNTP-60900	90*100	DNTP-61200	120*100
DNTP-60630	63*100	DNTP-60770	77*100	DNTP-60910	91*100	DNTP-61250	125*100
DNTP-60640	64*100	DNTP-60780	78*100	DNTP-60920	92*100	DNTP-61300	130*100
DNTP-60650	65*100	DNTP-60790	79*100	DNTP-60930	93*100	DNTP-61350	135*100
DNTP-60660	66*100	DNTP-60800	80*100	DNTP-60940	94*100	DNTP-61400	140*100
DNTP-60670	67*100	DNTP-60810	81*100	DNTP-60950	95*100	DNTP-61450	145*100
DNTP-60680	68*100	DNTP-60820	82*100	DNTP-60960	96*100	DNTP-61500	150*100
DNTP-60690	69*100	DNTP-60830	83*100	DNTP-60970	97*100		
DNTP-60700	70*100	DNTP-60840	84*100	DNTP-60980	98*100		
DNTP-60710	71*100	DNTP-60850	85*100	DNTP-60990	99*100		
DNTP-60720	72*100	DNTP-60860	86*100	DNTP-61000	100*100		
DNTP-60730	73*100	DNTP-60870	87*100	DNTP-61050	105*100		
DNTP-60740	74*100	DNTP-60880	88*100	DNTP-61100	110*100		

英制规格详见P499 INCH SIZE ON P499

选配件 OPTIONAL ACCESSORIES

匹配顶针 MATCHING PILOT PIN				推荐钻机 RECOMMENDED MAGNETIC DRILLING MACHINE		
钻头直径 DIAMETER	型号 MODEL	规格 SPECIFICATION	顶针 PILOT PIN	钻头直径 DIAMETER	钻机型号 MAGNETIC DRILLING MACHING	匹配夹具 MATCHING TOOL HOLDER
61-150	DPB-81167	7.98*167		61-150	DX-120	DJPY-100X-MT4

DNTP CARBIDE TIPPED ANNULAR CUTTER WITH P-TYPE WELDON SHANK 硬质合金P型直角柄钢板钻

- 直角柄型, 保证大规格钻孔时的夹持力与夹持精度, 适合直径61mm与以上规格;
- 专用硬质合金刀片, 分层及低摩擦力切削几何;
- 适合多种磁座钻机、钻床等设备上钻孔与环形槽加工;
- Weldon shank ensures the clamping force and clamping accuracy when drilling large diameter, and it is suitable for the diameter of 61mm and above;
- Special carbide tips with layered and low friction cutting geometry;
- Applicable to drilling and process of annular groove on various magnetic drilling machines and press.

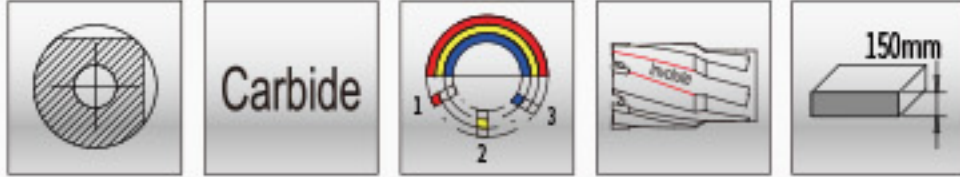
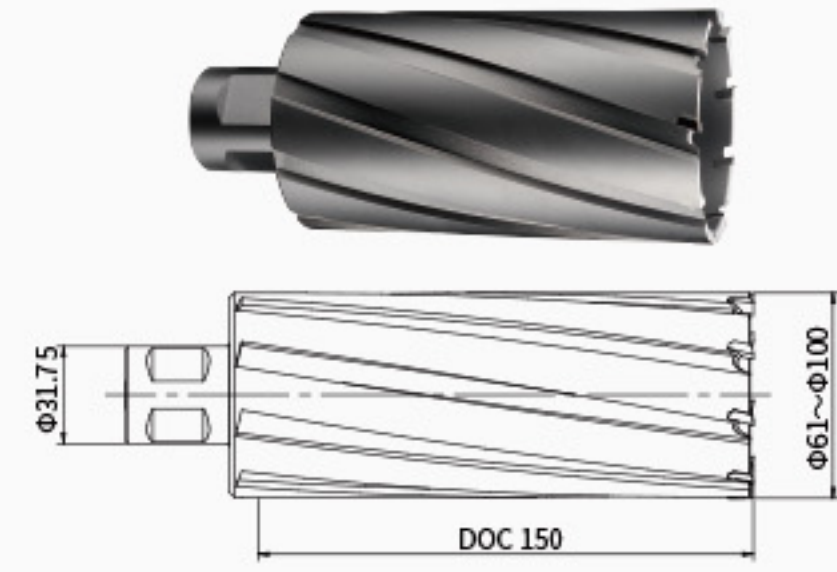

单位(Unit): mm

型号 MODEL	规格 SPECIFICATION	型号 MODEL	规格 SPECIFICATION	型号 MODEL	规格 SPECIFICATION	型号 MODEL	规格 SPECIFICATION
DNTP-70610	61*150	DNTP-70710	71*150	DNTP-70810	81*150	DNTP-70910	91*150
DNTP-70620	62*150	DNTP-70720	72*150	DNTP-70820	82*150	DNTP-70920	92*150
DNTP-70630	63*150	DNTP-70730	73*150	DNTP-70830	83*150	DNTP-70930	93*150
DNTP-70640	64*150	DNTP-70740	74*150	DNTP-70840	84*150	DNTP-70940	94*150
DNTP-70650	65*150	DNTP-70750	75*150	DNTP-70850	85*150	DNTP-70950	95*150
DNTP-70660	66*150	DNTP-70760	76*150	DNTP-70860	86*150	DNTP-70960	96*150
DNTP-70670	67*150	DNTP-70770	77*150	DNTP-70870	87*150	DNTP-70970	97*150
DNTP-70680	68*150	DNTP-70780	78*150	DNTP-70880	88*150	DNTP-70980	98*150
DNTP-70690	69*150	DNTP-70790	79*150	DNTP-70890	89*150	DNTP-70990	99*150
DNTP-70700	70*150	DNTP-70800	80*150	DNTP-70900	90*150	DNTP-71000	100*150

英制规格详见P500 INCH SIZE ON P500

选配件 OPTIONAL ACCESSORIES

匹配顶针 MATCHING PILOT PIN			
钻头直径 DIAMETER	型号 MODEL	规格 SPECIFICATION	顶针 PILOT PIN
61-100	DPT-82221	7.98*221	

顶针应用详见P635 PILOT PIN APPLICATION ON P635

DNTP CARBIDE TIPPED ANNULAR CUTTER WITH P-TYPE WELDON SHANK 硬质合金P型直角柄钢板钻

- 直角柄型, 保证大规格钻孔时的夹持力与夹持精度, 适合直径61mm与以上规格;
- 专用硬质合金刀片, 分层及低摩擦力切削几何;
- 适合多种磁座钻机、钻床等设备上钻孔与环形槽加工;
- Weldon shank ensures the clamping force and clamping accuracy when drilling large diameter, and it is suitable for the diameter of 61mm and above;
- Special carbide tips with layered and low friction cutting geometry;
- Applicable to drilling and process of annular groove on various magnetic drilling machines and press.

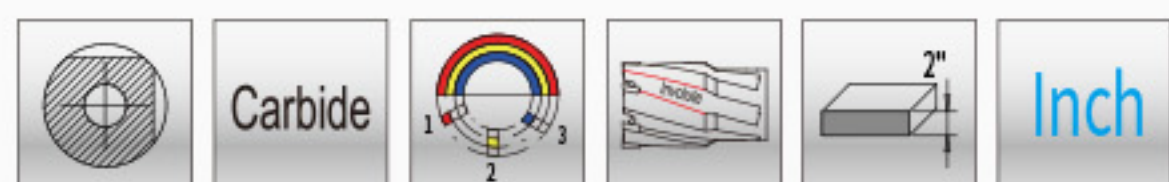
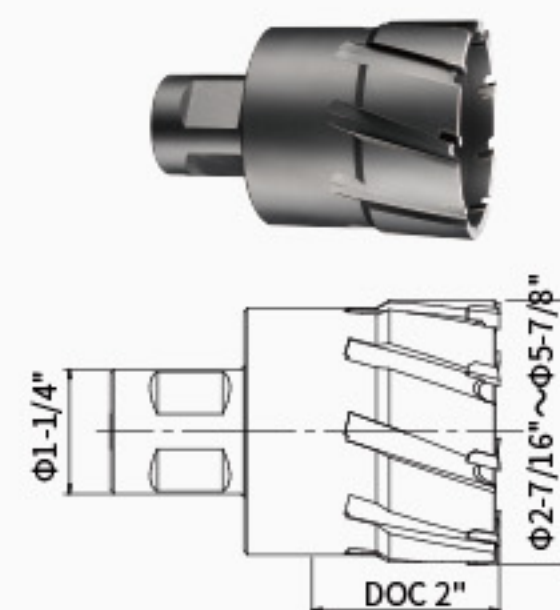

单位(Unit): inch

型号 MODEL	规格 SPECIFICATION	型号 MODEL	规格 SPECIFICATION	型号 MODEL	规格 SPECIFICATION	型号 MODEL	规格 SPECIFICATION
DNTP-D2437	2-7/16**2"	DNTP-D3125	3-1/8**2"	DNTP-D3812	3-13/16**2"	DNTP-D5000	5**2"
DNTP-D2500	2-1/2**2"	DNTP-D3187	3-3/16**2"	DNTP-D3875	3-7/8**2"	DNTP-D5125	5-1/8**2"
DNTP-D2562	2-9/16**2"	DNTP-D3250	3-1/4**2"	DNTP-D3937	3-15/16**2"	DNTP-D5250	5-1/4**2"
DNTP-D2625	2-5/8**2"	DNTP-D3312	3-5/16**2"	DNTP-D4000	4**2"	DNTP-D5375	5-3/8**2"
DNTP-D2687	2-11/16**2"	DNTP-D3375	3-3/8**2"	DNTP-D4125	4-1/8**2"	DNTP-D5500	5-1/2**2"
DNTP-D2750	2-3/4**2"	DNTP-D3437	3-7/16**2"	DNTP-D4250	4-1/4**2"	DNTP-D5625	5-5/8**2"
DNTP-D2812	2-13/16**2"	DNTP-D3500	3-1/2**2"	DNTP-D4375	4-3/8**2"	DNTP-D5750	5-3/4**2"
DNTP-D2875	2-7/8**2"	DNTP-D3562	3-9/16**2"	DNTP-D4500	4-1/2**2"	DNTP-D5875	5-7/8**2"
DNTP-D2937	2-15/16**2"	DNTP-D3625	3-5/8**2"	DNTP-D4625	4-5/8**2"		
DNTP-D3000	3**2"	DNTP-D3687	3-11/16**2"	DNTP-D4750	4-3/4**2"		
DNTP-D3062	3-1/16**2"	DNTP-D3750	3-3/4**2"	DNTP-D4875	4-7/8**2"		

公制规格详见P469 METRIC SIZE ON P469

选配件 OPTIONAL ACCESSORIES

钻头直径 DIAMETER	匹配顶针 MATCHING PILOT PIN			推荐钻机 RECOMMENDED MAGNETIC DRILLING MACHINE		
	型号 MODEL	规格 SPECIFICATION	顶针 PILOT PIN	钻头直径 DIAMETER	钻机型号 MAGNETIC DRILLING MACHING	匹配夹具 MATCHING TOOL HOLDER
2-7/16"-5-7/8"	DPB-81115	7.98*115		2-7/16"-5-7/8"	DX-120	DJPY-50X-MT4

DNTP CARBIDE TIPPED ANNULAR CUTTER WITH P-TYPE WELDON SHANK 硬质合金P型直角柄钢板钻

- 直角柄型, 保证大规格钻孔时的夹持力与夹持精度, 适合直径61mm与以上规格;
- 专用硬质合金刀片, 分层及低摩擦力切削几何;
- 适合多种磁座钻机、钻床等设备上钻孔与环形槽加工;
- Weldon shank ensures the clamping force and clamping accuracy when drilling large diameter, and it is suitable for the diameter of 61mm and above;
- Special carbide tips with layered and low friction cutting geometry;
- Applicable to drilling and process of annular groove on various magnetic drilling machines and press.

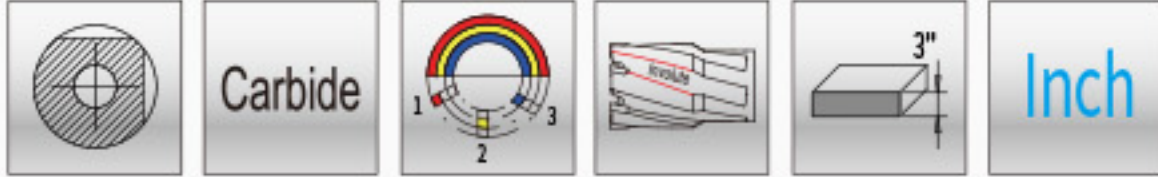
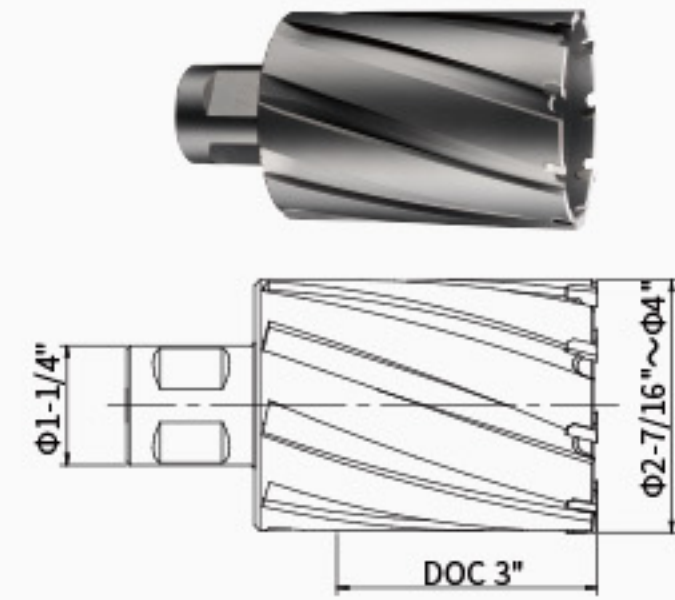

单位(Unit): inch

型号 MODEL	规格 SPECIFICATION	型号 MODEL	规格 SPECIFICATION	型号 MODEL	规格 SPECIFICATION	型号 MODEL	规格 SPECIFICATION
DNTP-E2437	2-7/16**3"	DNTP-E2875	2-7/8**3"	DNTP-E3312	3-5/16**3"	DNTP-E3750	3-3/4**3"
DNTP-E2500	2-1/2**3"	DNTP-E2937	2-15/16**3"	DNTP-E3375	3-3/8**3"	DNTP-E3812	3-13/16**3"
DNTP-E2562	2-9/16**3"	DNTP-E3000	3**3"	DNTP-E3437	3-7/16**3"	DNTP-E3875	3-7/8**3"
DNTP-E2625	2-5/8**3"	DNTP-E3062	3-1/16**3"	DNTP-E3500	3-1/2**3"	DNTP-E3937	3-15/16**3"
DNTP-E2687	2-11/16**3"	DNTP-E3125	3-1/8**3"	DNTP-E3562	3-9/16**3"	DNTP-E4000	4**3"
DNTP-E2750	2-3/4**3"	DNTP-E3187	3-3/16**3"	DNTP-E3625	3-5/8**3"		
DNTP-E2812	2-13/16**3"	DNTP-E3250	3-1/4**3"	DNTP-E3687	3-11/16**3"		

公制规格详见P470 METRIC SIZE ON P470

选配件 OPTIONAL ACCESSORIES

钻头直径 DIAMETER	匹配顶针 MATCHING PILOT PIN			推荐钻机 RECOMMENDED MAGNETIC DRILLING MACHINE		
	型号 MODEL	规格 SPECIFICATION	顶针 PILOT PIN	钻头直径 DIAMETER	钻机型号 MAGNETIC DRILLING MACHING	匹配夹具 MATCHING TOOL HOLDER
2-7/16"-4"	DPB-81145	7.98*145		2-7/16"-4"	DX-120	DJPY-75X-MT4



DNTP CARBIDE TIPPED ANNULAR CUTTER WITH P-TYPE WELDON SHANK 硬质合金P型直角柄钢板钻

- 直角柄型, 保证大规格钻孔时的夹持力与夹持精度, 适合直径61mm与以上规格;
- 专用硬质合金刀片, 分层及低摩擦力切削几何;
- 适合多种磁座钻机、钻床等设备上钻孔与环形槽加工;
- Weldon shank ensures the clamping force and clamping accuracy when drilling large diameter, and it is suitable for the diameter of 61mm and above;
- Special carbide tips with layered and low friction cutting geometry;
- Applicable to drilling and process of annular groove on various magnetic drilling machines and press.

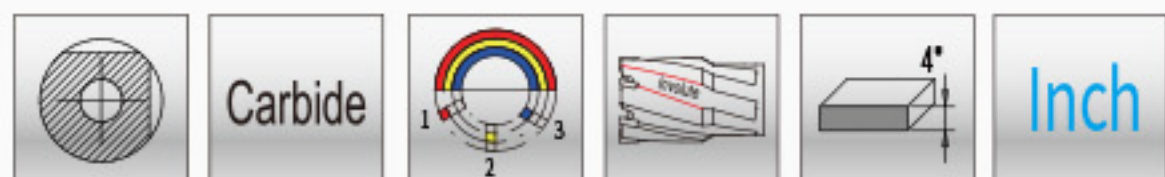
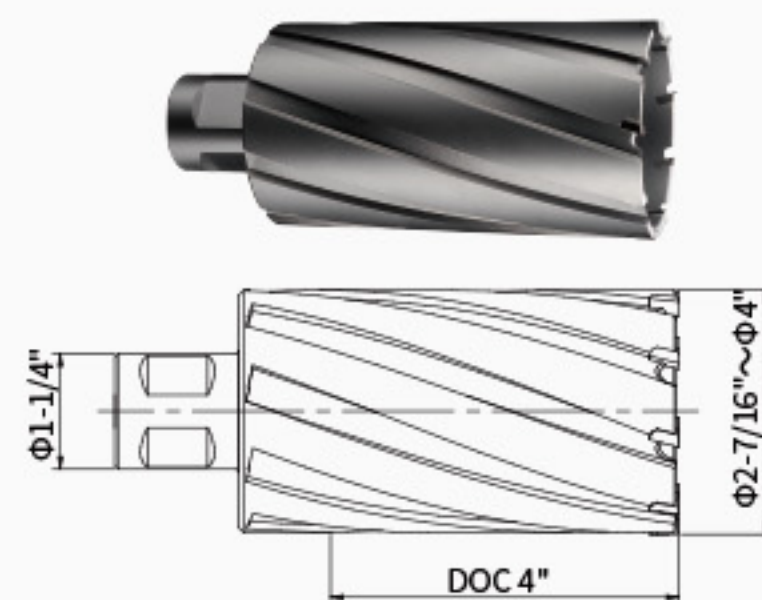

单位(Unit): inch

型号 MODEL	规格 SPECIFICATION	型号 MODEL	规格 SPECIFICATION	型号 MODEL	规格 SPECIFICATION	型号 MODEL	规格 SPECIFICATION
DNTP-F2437	2-7/16**4"	DNTP-F2875	2-7/8**4"	DNTP-F3312	3-5/16**4"	DNTP-F3750	3-3/4**4"
DNTP-F2500	2-1/2**4"	DNTP-F2937	2-15/16**4"	DNTP-F3375	3-3/8**4"	DNTP-F3812	3-13/16**4"
DNTP-F2562	2-9/16**4"	DNTP-F3000	3**4"	DNTP-F3437	3-7/16**4"	DNTP-F3875	3-7/8**4"
DNTP-F2625	2-5/8**4"	DNTP-F3062	3-1/16**4"	DNTP-F3500	3-1/2**4"	DNTP-F3937	3-15/16**4"
DNTP-F2687	2-11/16**4"	DNTP-F3125	3-1/8**4"	DNTP-F3562	3-9/16**4"	DNTP-F4000	4**4"
DNTP-F2750	2-3/4**4"	DNTP-F3187	3-3/16**4"	DNTP-F3625	3-5/8**4"		
DNTP-F2812	2-13/16**4"	DNTP-F3250	3-1/4**4"	DNTP-F3687	3-11/16**4"		

公制规格详见P471 METRIC SIZE ON P471

选配件 OPTIONAL ACCESSORIES

钻头直径 DIAMETER	匹配顶针 MATCHING PILOT PIN			推荐钻机 RECOMMENDED MAGNETIC DRILLING MACHINE		
	型号 MODEL	规格 SPECIFICATION	顶针 PILOT PIN	钻头直径 DIAMETER	钻机型号 MAGNETIC DRILLING MACHING	匹配夹具 MATCHING TOOL HOLDER
2-7/16"-4"	DPB-81167	7.98*167		2-7/16"-4"	DX-120	DJPY-100X-MT4

DNTP CARBIDE TIPPED ANNULAR CUTTER WITH P-TYPE WELDON SHANK 硬质合金P型直角柄钢板钻

- 直角柄型, 保证大规格钻孔时的夹持力与夹持精度, 适合直径61mm与以上规格;
- 专用硬质合金刀片, 分层及低摩擦力切削几何;
- 适合多种磁座钻机、钻床等设备上钻孔与环形槽加工;
- Weldon shank ensures the clamping force and clamping accuracy when drilling large diameter, and it is suitable for the diameter of 61mm and above;
- Special carbide tips with layered and low friction cutting geometry;
- Applicable to drilling and process of annular groove on various magnetic drilling machines and press.

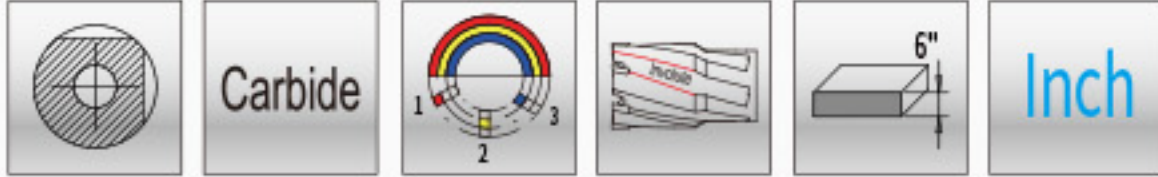
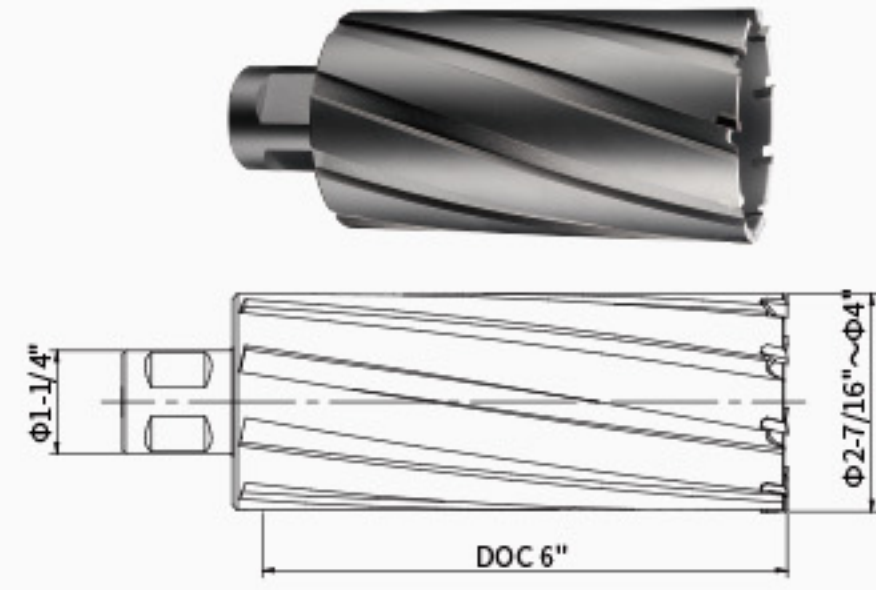

单位(Unit): inch

型号 MODEL	规格 SPECIFICATION	型号 MODEL	规格 SPECIFICATION	型号 MODEL	规格 SPECIFICATION	型号 MODEL	规格 SPECIFICATION
DNTP-G2437	2-7/16**6"	DNTP-G2875	2-7/8**6"	DNTP-G3312	3-5/16**6"	DNTP-G3750	3-3/4**6"
DNTP-G2500	2-1/2**6"	DNTP-G2937	2-15/16**6"	DNTP-G3375	3-3/8**6"	DNTP-G3812	3-13/16**6"
DNTP-G2562	2-9/16**6"	DNTP-G3000	3**6"	DNTP-G3437	3-7/16**6"	DNTP-G3875	3-7/8**6"
DNTP-G2625	2-5/8**6"	DNTP-G3062	3-1/16**6"	DNTP-G3500	3-1/2**6"	DNTP-G3937	3-15/16**6"
DNTP-G2687	2-11/16**6"	DNTP-G3125	3-1/8**6"	DNTP-G3562	3-9/16**6"	DNTP-G4000	4**6"
DNTP-G2750	2-3/4**6"	DNTP-G3187	3-3/16**6"	DNTP-G3625	3-5/8**6"		
DNTP-G2812	2-13/16**6"	DNTP-G3250	3-1/4**6"	DNTP-G3687	3-11/16**6"		

公制规格详见P472 METRIC SIZE ON P472

选配件 OPTIONAL ACCESSORIES

钻头直径 DIAMETER	匹配顶针 MATCHING PILOT PIN		
	型号 MODEL	规格 SPECIFICATION	顶针 PILOT PIN
2-7/16*-4"	DPT-82221	7.98*221	

顶针应用详见P635 PILOT PIN APPLICATION ON P635