

DNTR CARBIDE TIPPED ANNULAR CUTTER WITH R-TYPE ROUND SHANK 硬质合金R型圆销柄钢板钻

- 圆销柄型, 适合专用钻机接口;
- 专用硬质合金刀片, 分层及低摩擦力切削几何;
- Round shank. Suitable for special purpose magnetic drilling machines;
- Special carbide tips with layered and low friction cutting geometry.

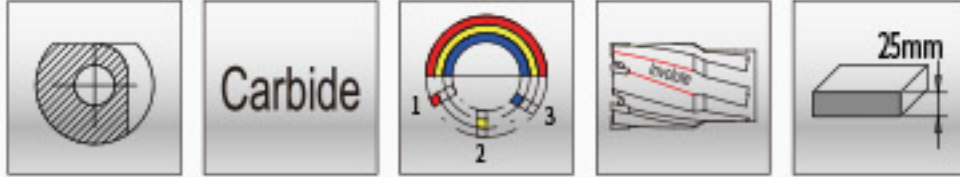
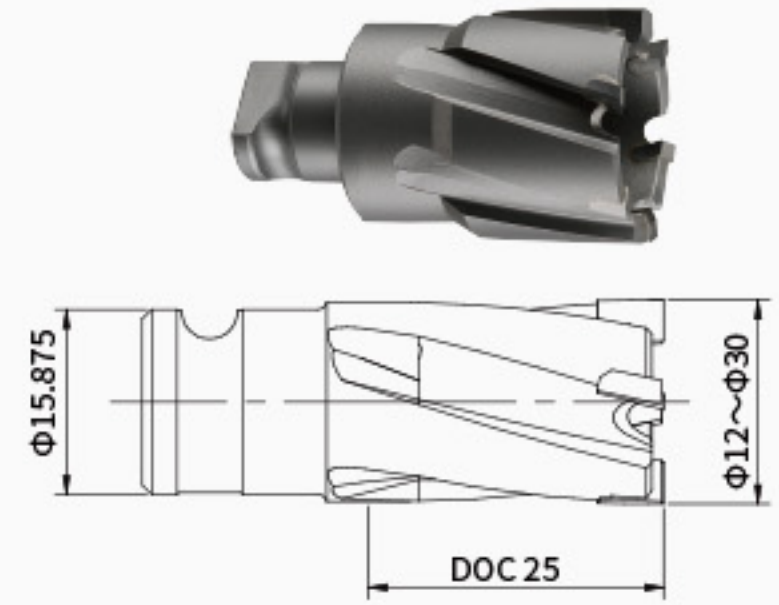

单位(Unit): mm

型号 MODEL	规格 SPECIFICATION	型号 MODEL	规格 SPECIFICATION	型号 MODEL	规格 SPECIFICATION	型号 MODEL	规格 SPECIFICATION
DNTR-20120	12*25	DNTR-20170	17*25	DNTR-20220	22*25	DNTR-20270	27*25
DNTR-20130	13*25	DNTR-20180	18*25	DNTR-20230	23*25	DNTR-20280	28*25
DNTR-20140	14*25	DNTR-20190	19*25	DNTR-20240	24*25	DNTR-20290	29*25
DNTR-20150	15*25	DNTR-20200	20*25	DNTR-20250	25*25	DNTR-20300	30*25
DNTR-20160	16*25	DNTR-20210	21*25	DNTR-20260	26*25		

选配件 OPTIONAL ACCESSORIES

匹配顶针 MATCHING PILOT PIN			
钻头直径 DIAMETER	型号 MODEL	规格 SPECIFICATION	顶针 PILOT PIN
12-30	DPB-41062	4.74*62	