

# DNTX CARBIDE TIPPED ANNULAR CUTTER WITH X-TYPE WELDON SHANK 硬质合金X型直角柄钢板钻

- 直角柄型, 有稳固的夹持力, 更好的保证钻孔稳定性与钻孔精度;
- 专用硬质合金刀片, 分层及低摩擦力切削几何;
- 适合多种磁座钻机、钻床等设备上钻孔与环形槽加工;
- Weldon shank, with more stable clamping force, better stability for drilling and better precision of holes;
- Special carbide tips with layered and low friction cutting geometry
- Applicable to drilling and process of annular groove on various magnetic drilling machines and press.

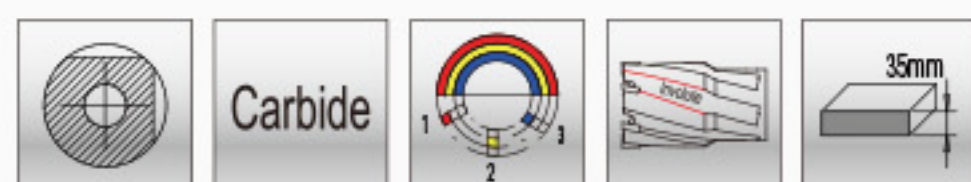
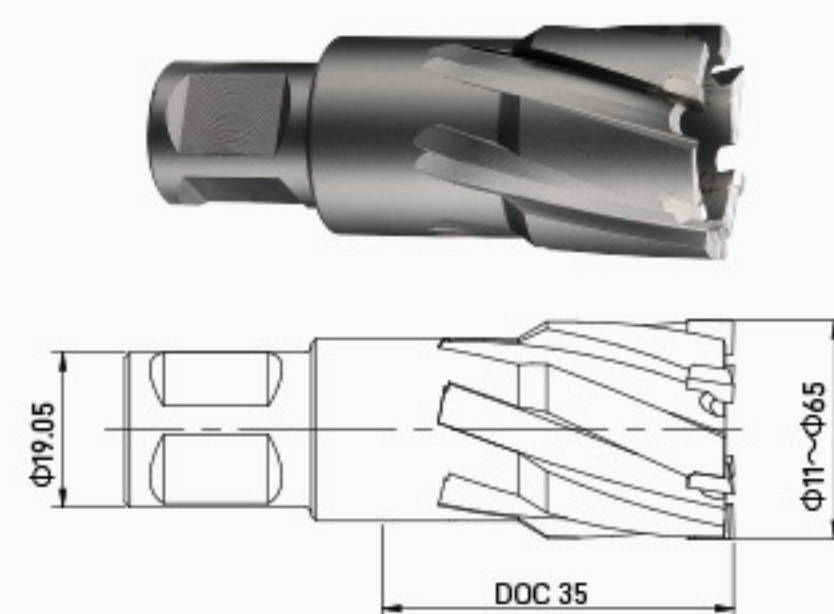

单位(Unit): mm

型号 MODEL	规格 SPECIFICATION	型号 MODEL	规格 SPECIFICATION	型号 MODEL	规格 SPECIFICATION	型号 MODEL	规格 SPECIFICATION
DNTX-30110	11*35	DNTX-30245	24.5*35	DNTX-30410	41*35	DNTX-30590	59*35
DNTX-30120	12*35	DNTX-30250	25*35	DNTX-30420	42*35	DNTX-30600	60*35
DNTX-30130	13*35	DNTX-30260	26*35	DNTX-30430	43*35	DNTX-30610	61*35
DNTX-30140	14*35	DNTX-30265	26.5*35	DNTX-30440	44*35	DNTX-30620	62*35
DNTX-30150	15*35	DNTX-30270	27*35	DNTX-30450	45*35	DNTX-30630	63*35
DNTX-30160	16*35	DNTX-30280	28*35	DNTX-30460	46*35	DNTX-30640	64*35
DNTX-30170	17*35	DNTX-30290	29*35	DNTX-30470	47*35	DNTX-30650	65*35
DNTX-30180	18*35	DNTX-30300	30*35	DNTX-30480	48*35		
DNTX-30185	18.5*35	DNTX-30310	31*35	DNTX-30490	49*35		
DNTX-30190	19*35	DNTX-30320	32*35	DNTX-30500	50*35		
DNTX-30200	20*35	DNTX-30330	33*35	DNTX-30510	51*35		
DNTX-30205	20.5*35	DNTX-30340	34*35	DNTX-30520	52*35		
DNTX-30210	21*35	DNTX-30350	35*35	DNTX-30530	53*35		
DNTX-30215	21.5*35	DNTX-30360	36*35	DNTX-30540	54*35		
DNTX-30220	22*35	DNTX-30370	37*35	DNTX-30550	55*35		
DNTX-30225	22.5*35	DNTX-30380	38*35	DNTX-30560	56*35		
DNTX-30230	23*35	DNTX-30390	39*35	DNTX-30570	57*35		
DNTX-30240	24*35	DNTX-30400	40*35	DNTX-30580	58*35		

英制规格详见P489 INCH SIZE ON P489

## 选配件 OPTIONAL ACCESSORIES

匹配顶针 MATCHING PILOT PIN				推荐钻机 RECOMMENDED MAGNETIC DRILLING MACHINE		
钻头直径 DIAMETER	型号 MODEL	规格 SPECIFICATION	顶针 PILOT PIN	钻头直径 DIAMETER	钻机型号 MAGNETIC DRILLING MACHING	匹配夹具 MATCHING TOOL HOLDER
11	DPB-42090	4.75*90		11	DX-35	—
12-17	DPB-62090	6.34*90		12-17	DX-35	—
18-65	DPB-81090	7.98*90			DX-35	—
					DX-60	DJXY-50D-MT3
					DX-120	DJXY-50X-MT4



# DNTX CARBIDE TIPPED ANNULAR CUTTER WITH X-TYPE WELDON SHANK

## 硬质合金X型直角柄钢板钻

- 直角柄型, 有稳固的夹持力, 更好的保证钻孔稳定性与钻孔精度;
- 专用硬质合金刀片, 分层及低摩擦力切削几何;
- 适合多种磁座钻机、钻床等设备上钻孔与环形槽加工;
- Weldon shank, with more stable clamping force, better stability for drilling and better precision of holes;
- Special carbide tips with layered and low friction cutting geometry
- Applicable to drilling and process of annular groove on various magnetic drilling machines and press.

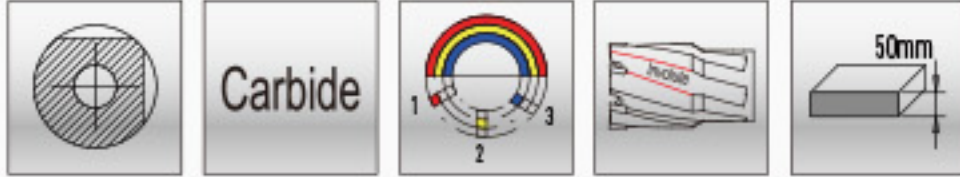
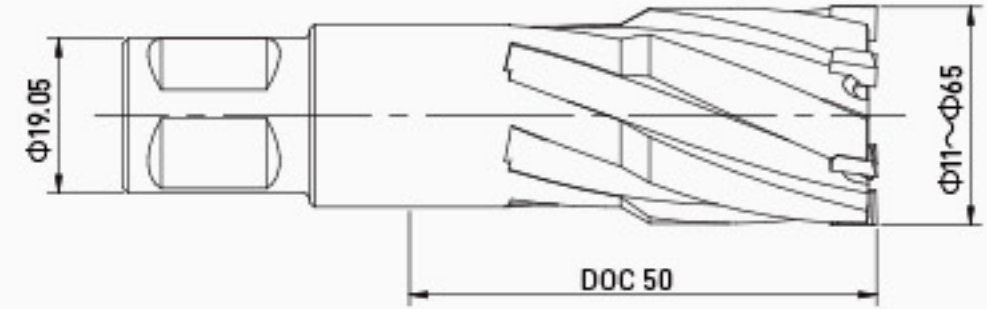

单位(Unit): mm

型号 MODEL	规格 SPECIFICATION	型号 MODEL	规格 SPECIFICATION	型号 MODEL	规格 SPECIFICATION	型号 MODEL	规格 SPECIFICATION
DNTX-40110	11*50	DNTX-40245	24.5*50	DNTX-40410	41*50	DNTX-40590	59*50
DNTX-40120	12*50	DNTX-40250	25*50	DNTX-40420	42*50	DNTX-40600	60*50
DNTX-40130	13*50	DNTX-40260	26*50	DNTX-40430	43*50	DNTX-40610	61*50
DNTX-40140	14*50	DNTX-40265	26.5*50	DNTX-40440	44*50	DNTX-40620	62*50
DNTX-40150	15*50	DNTX-40270	27*50	DNTX-40450	45*50	DNTX-40630	63*50
DNTX-40160	16*50	DNTX-40280	28*50	DNTX-40460	46*50	DNTX-40640	64*50
DNTX-40170	17*50	DNTX-40290	29*50	DNTX-40470	47*50	DNTX-40650	65*50
DNTX-40180	18*50	DNTX-40300	30*50	DNTX-40480	48*50		
DNTX-40185	18.5*50	DNTX-40310	31*50	DNTX-40490	49*50		
DNTX-40190	19*50	DNTX-40320	32*50	DNTX-40500	50*50		
DNTX-40200	20*50	DNTX-40330	33*50	DNTX-40510	51*50		
DNTX-40205	20.5*50	DNTX-40340	34*50	DNTX-40520	52*50		
DNTX-40210	21*50	DNTX-40350	35*50	DNTX-40530	53*50		
DNTX-40215	21.5*50	DNTX-40360	36*50	DNTX-40540	54*50		
DNTX-40220	22*50	DNTX-40370	37*50	DNTX-40550	55*50		
DNTX-40225	22.5*50	DNTX-40380	38*50	DNTX-40560	56*50		
DNTX-40230	23*50	DNTX-40390	39*50	DNTX-40570	57*50		
DNTX-40240	24*50	DNTX-40400	40*50	DNTX-40580	58*50		

英制规格详见P490 INCH SIZE ON P490

### 选配件 OPTIONAL ACCESSORIES

匹配顶针 MATCHING PILOT PIN				推荐钻机 RECOMMENDED MAGNETIC DRILLING MACHINE		
钻头直径 DIAMETER	型号 MODEL	规格 SPECIFICATION	顶针 PILOT PIN	钻头直径 DIAMETER	钻机型号 MAGNETIC DRILLING MACHING	匹配夹具 MATCHING TOOL HOLDER
11	DPB-42102	4.75*102		11	DX-35	—
12-17	DPB-62102	6.34*102		12-17	DX-35	—
18-65	DPB-81103	7.98*103			DX-35	—
					DX-60	DJXY-50D-MT3
					DX-120	DJXY-50X-MT4



# DNTX CARBIDE TIPPED ANNULAR CUTTER WITH X-TYPE WELDON SHANK 硬质合金X型直角柄钢板钻

- 直角柄型, 有稳固的夹持力, 更好的保证钻孔稳定性与钻孔精度;
- 专用硬质合金刀片, 分层及低摩擦力切削几何;
- 适合多种磁座钻机、钻床等设备上钻孔与环形槽加工;
- Weldon shank, with more stable clamping force, better stability for drilling and better precision of holes;
- Special carbide tips with layered and low friction cutting geometry
- Applicable to drilling and process of annular groove on various magnetic drilling machines and press.

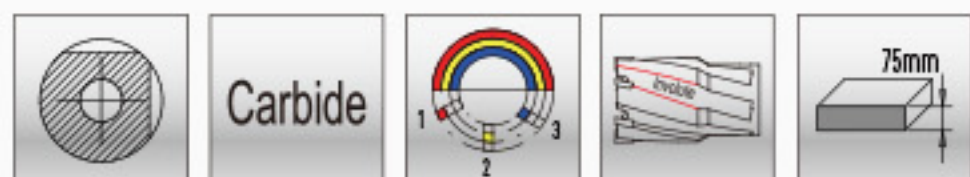
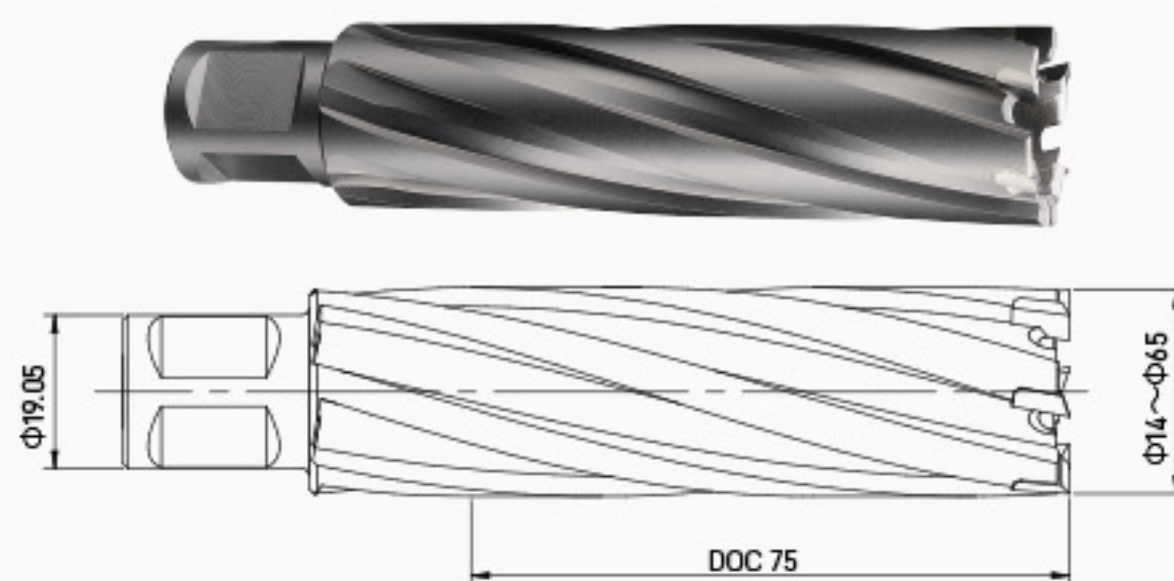

单位(Unit): mm

型号 MODEL	规格 SPECIFICATION	型号 MODEL	规格 SPECIFICATION	型号 MODEL	规格 SPECIFICATION	型号 MODEL	规格 SPECIFICATION
DNTX-50140	14*75	DNTX-50270	27*75	DNTX-50400	40*75	DNTX-50530	53*75
DNTX-50150	15*75	DNTX-50280	28*75	DNTX-50410	41*75	DNTX-50540	54*75
DNTX-50160	16*75	DNTX-50290	29*75	DNTX-50420	42*75	DNTX-50550	55*75
DNTX-50170	17*75	DNTX-50300	30*75	DNTX-50430	43*75	DNTX-50560	56*75
DNTX-50180	18*75	DNTX-50310	31*75	DNTX-50440	44*75	DNTX-50570	57*75
DNTX-50190	19*75	DNTX-50320	32*75	DNTX-50450	45*75	DNTX-50580	58*75
DNTX-50200	20*75	DNTX-50330	33*75	DNTX-50460	46*75	DNTX-50590	59*75
DNTX-50210	21*75	DNTX-50340	34*75	DNTX-50470	47*75	DNTX-50600	60*75
DNTX-50220	22*75	DNTX-50350	35*75	DNTX-50480	48*75	DNTX-50610	61*75
DNTX-50230	23*75	DNTX-50360	36*75	DNTX-50490	49*75	DNTX-50620	62*75
DNTX-50240	24*75	DNTX-50370	37*75	DNTX-50500	50*75	DNTX-50630	63*75
DNTX-50250	25*75	DNTX-50380	38*75	DNTX-50510	51*75	DNTX-50640	64*75
DNTX-50260	26*75	DNTX-50390	39*75	DNTX-50520	52*75	DNTX-50650	65*75

英制规格详见P491 INCH SIZE ON P491

## 选配件 OPTIONAL ACCESSORIES

匹配顶针 MATCHING PILOT PIN				推荐钻机 RECOMMENDED MAGNETIC DRILLING MACHINE		
钻头直径 DIAMETER	型号 MODEL	规格 SPECIFICATION	顶针 PILOT PIN	钻头直径 DIAMETER	钻机型号 MAGNETIC DRILLING MACHING	匹配夹具 MATCHING TOOL HOLDER
14-17	DPB-62130	6.34*130		14-17	DX-60	DJXY-75X-MT3
18-65	DPB-81130	7.98*130		18-65	DX-60	DJXY-75X-MT3
				18-65	DX-120	DJXY-75X-MT4



# DNTX CARBIDE TIPPED ANNULAR CUTTER WITH X-TYPE WELDON SHANK 硬质合金X型直角柄钢板钻

- 直角柄型, 有稳固的夹持力, 更好的保证钻孔稳定性与钻孔精度;
- 专用硬质合金刀片, 分层及低摩擦力切削几何;
- 适合多种磁座钻机、钻床等设备上钻孔与环形槽加工;
- Weldon shank, with more stable clamping force, better stability for drilling and better precision of holes;
- Special carbide tips with layered and low friction cutting geometry
- Applicable to drilling and process of annular groove on various magnetic drilling machines and press.

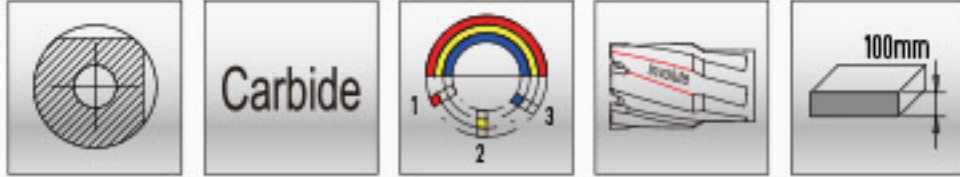
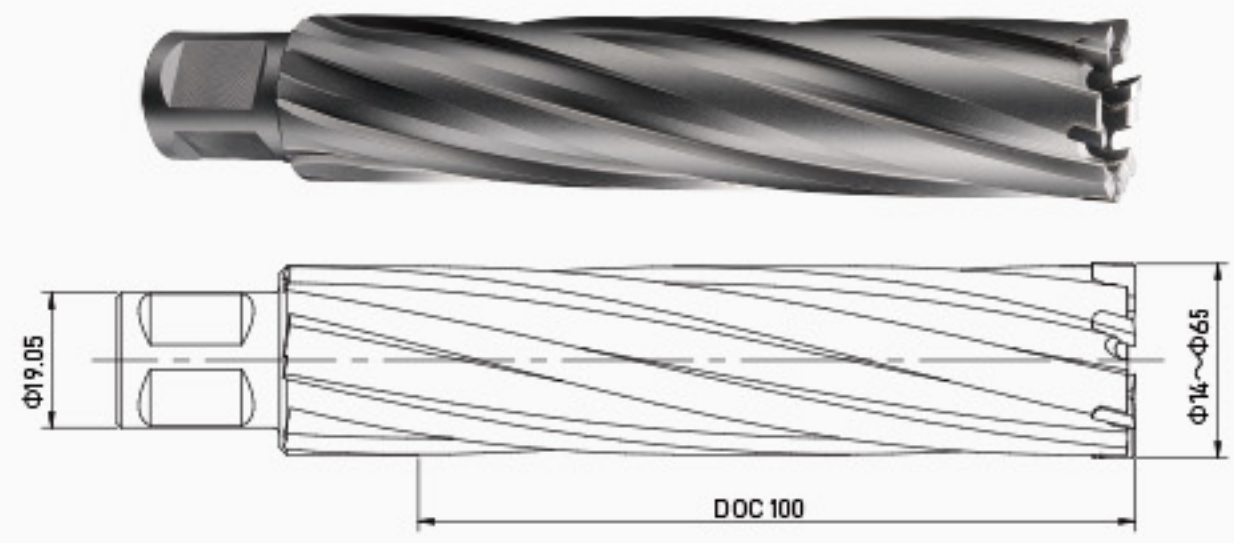

单位(Unit): mm

型号 MODEL	规格 SPECIFICATION	型号 MODEL	规格 SPECIFICATION	型号 MODEL	规格 SPECIFICATION	型号 MODEL	规格 SPECIFICATION
DNTX-60140	14*100	DNTX-60270	27*100	DNTX-60400	40*100	DNTX-60530	53*100
DNTX-60150	15*100	DNTX-60280	28*100	DNTX-60410	41*100	DNTX-60540	54*100
DNTX-60160	16*100	DNTX-60290	29*100	DNTX-60420	42*100	DNTX-60550	55*100
DNTX-60170	17*100	DNTX-60300	30*100	DNTX-60430	43*100	DNTX-60560	56*100
DNTX-60180	18*100	DNTX-60310	31*100	DNTX-60440	44*100	DNTX-60570	57*100
DNTX-60190	19*100	DNTX-60320	32*100	DNTX-60450	45*100	DNTX-60580	58*100
DNTX-60200	20*100	DNTX-60330	33*100	DNTX-60460	46*100	DNTX-60590	59*100
DNTX-60210	21*100	DNTX-60340	34*100	DNTX-60470	47*100	DNTX-60600	60*100
DNTX-60220	22*100	DNTX-60350	35*100	DNTX-60480	48*100	DNTX-60610	61*100
DNTX-60230	23*100	DNTX-60360	36*100	DNTX-60490	49*100	DNTX-60620	62*100
DNTX-60240	24*100	DNTX-60370	37*100	DNTX-60500	50*100	DNTX-60630	63*100
DNTX-60250	25*100	DNTX-60380	38*100	DNTX-60510	51*100	DNTX-60640	64*100
DNTX-60260	26*100	DNTX-60390	39*100	DNTX-60520	52*100	DNTX-60650	65*100

英制规格详见P492 INCH SIZE ON P492

## 选配件 OPTIONAL ACCESSORIES

匹配顶针 MATCHING PILOT PIN				推荐钻机 RECOMMENDED MAGNETIC DRILLING MACHINE		
钻头直径 DIAMETER	型号 MODEL	规格 SPECIFICATION	顶针 PILOT PIN	钻头直径 DIAMETER	钻机型号 MAGNETIC DRILLING MACHING	匹配夹具 MATCHING TOOL HOLDER
14-17	DPB-62160	6.34*160		14-17	DX-120	DJXY-100X-MT4
18-65	DPB-81160	7.98*160		18-65		



# DNTX CARBIDE TIPPED ANNULAR CUTTER WITH X-TYPE WELDON SHANK 硬质合金X型直角柄钢板钻

- 直角柄型, 有稳固的夹持力, 更好的保证钻孔稳定性与钻孔精度;
- 专用硬质合金刀片, 分层及低摩擦力切削几何;
- 适合多种磁座钻机、钻床等设备上钻孔与环形槽加工;
- Weldon shank, with more stable clamping force, better stability for drilling and better precision of holes;
- Special carbide tips with layered and low friction cutting geometry
- Applicable to drilling and process of annular groove on various magnetic drilling machines and press.

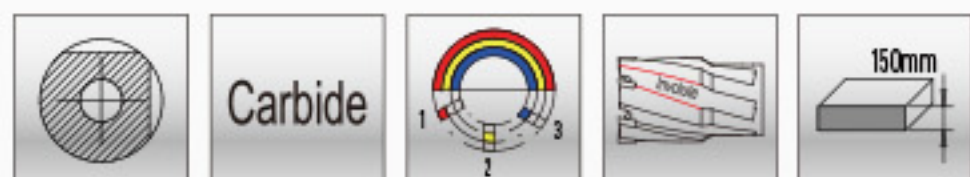
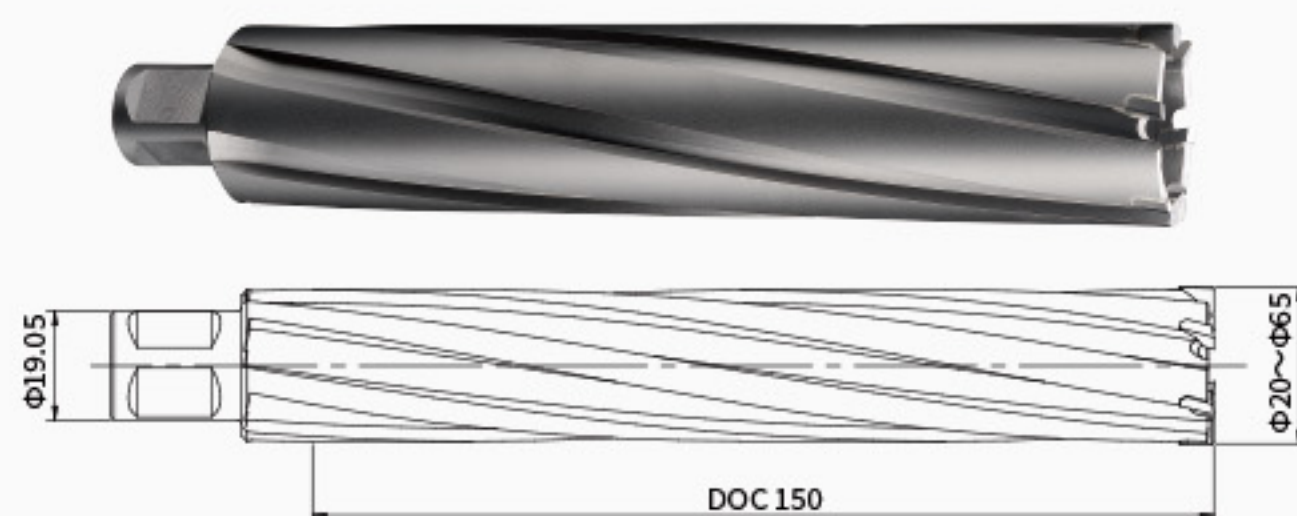

单位(Unit): mm

型号 MODEL	规格 SPECIFICATION	型号 MODEL	规格 SPECIFICATION	型号 MODEL	规格 SPECIFICATION	型号 MODEL	规格 SPECIFICATION
DNTX-70200	20*150	DNTX-70320	32*150	DNTX-70440	44*150	DNTX-70560	56*150
DNTX-70210	21*150	DNTX-70330	33*150	DNTX-70450	45*150	DNTX-70570	57*150
DNTX-70220	22*150	DNTX-70340	34*150	DNTX-70460	46*150	DNTX-70580	58*150
DNTX-70230	23*150	DNTX-70350	35*150	DNTX-70470	47*150	DNTX-70590	59*150
DNTX-70240	24*150	DNTX-70360	36*150	DNTX-70480	48*150	DNTX-70600	60*150
DNTX-70250	25*150	DNTX-70370	37*150	DNTX-70490	49*150	DNTX-70610	61*150
DNTX-70260	26*150	DNTX-70380	38*150	DNTX-70500	50*150	DNTX-70620	62*150
DNTX-70270	27*150	DNTX-70390	39*150	DNTX-70510	51*150	DNTX-70630	63*150
DNTX-70280	28*150	DNTX-70400	40*150	DNTX-70520	52*150	DNTX-70640	64*150
DNTX-70290	29*150	DNTX-70410	41*150	DNTX-70530	53*150	DNTX-70650	65*150
DNTX-70300	30*150	DNTX-70420	42*150	DNTX-70540	54*150		
DNTX-70310	31*150	DNTX-70430	43*150	DNTX-70550	55*150		

英制规格详见P493 INCH SIZE ON P493

## 选配件 OPTIONAL ACCESSORIES

匹配顶针 MATCHING PILOT PIN			
钻头直径 DIAMETER	型号 MODEL	规格 SPECIFICATION	顶针 PILOT PIN
20-65	DPT-82205	7.98*205	

顶针应用详见P635 PILOT PIN APPLICATION ON P631



# DNTX CARBIDE TIPPED ANNULAR CUTTER WITH X-TYPE WELDON SHANK 硬质合金X型直角柄钢板钻

- 直角柄型, 有稳固的夹持力, 更好的保证钻孔稳定性与钻孔精度;
- 专用硬质合金刀片, 分层及低摩擦力切削几何;
- 适合多种磁座钻机、钻床等设备上钻孔与环形槽加工;
- Weldon shank, with more stable clamping force, better stability for drilling and better precision of holes;
- Special carbide tips with layered and low friction cutting geometry
- Applicable to drilling and process of annular groove on various magnetic drilling machines and press.

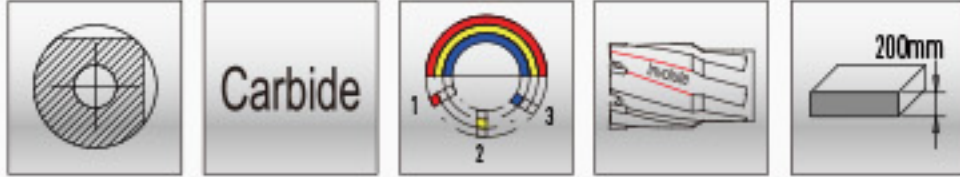
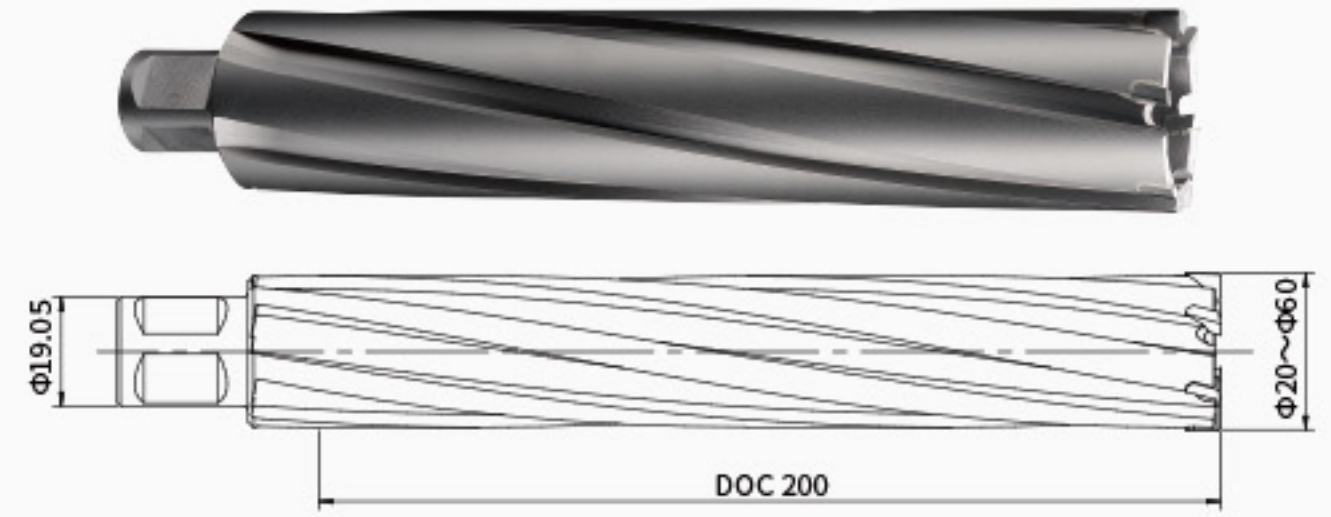

单位(Unit): mm

型号 MODEL	规格 SPECIFICATION	型号 MODEL	规格 SPECIFICATION	型号 MODEL	规格 SPECIFICATION	型号 MODEL	规格 SPECIFICATION
DNTX-80200	20*200	DNTX-80320	32*200	DNTX-80440	44*200	DNTX-80560	56*200
DNTX-80210	21*200	DNTX-80330	33*200	DNTX-80450	45*200	DNTX-80570	57*200
DNTX-80220	22*200	DNTX-80340	34*200	DNTX-80460	46*200	DNTX-80580	58*200
DNTX-80230	23*200	DNTX-80350	35*200	DNTX-80470	47*200	DNTX-80590	59*200
DNTX-80240	24*200	DNTX-80360	36*200	DNTX-80480	48*200	DNTX-80600	60*200
DNTX-80250	25*200	DNTX-80370	37*200	DNTX-80490	49*200		
DNTX-80260	26*200	DNTX-80380	38*200	DNTX-80500	50*200		
DNTX-80270	27*200	DNTX-80390	39*200	DNTX-80510	51*200		
DNTX-80280	28*200	DNTX-80400	40*200	DNTX-80520	52*200		
DNTX-80290	29*200	DNTX-80410	41*200	DNTX-80530	53*200		
DNTX-80300	30*200	DNTX-80420	42*200	DNTX-80540	54*200		
DNTX-80310	31*200	DNTX-80430	43*200	DNTX-80550	55*200		

## 选配件 OPTIONAL ACCESSORIES

匹配顶针 MATCHING PILOT PIN			
钻头直径 DIAMETER	型号 MODEL	规格 SPECIFICATION	顶针 PILOT PIN
20-60	DPT-82256	7.98*256	

顶针应用详见P635 PILOT PIN APPLICATION ON P631



# DNTX CARBIDE TIPPED ANNULAR CUTTER WITH X-TYPE WELDON SHANK 硬质合金X型直角柄钢板钻

- 直角柄型, 有稳固的夹持力, 更好的保证钻孔稳定性与钻孔精度;
- 专用硬质合金刀片, 分层及低摩擦力切削几何;
- 适合多种磁座钻机、钻床等设备上钻孔与环形槽加工;
- 可涂层;
- Weldon shank, with more stable clamping force, better stability for drilling and better precision of holes;
- Special carbide tips with layered and low friction cutting geometry;
- Applicable to drilling and process of annular groove on various magnetic drilling machines and press;
- PVD;

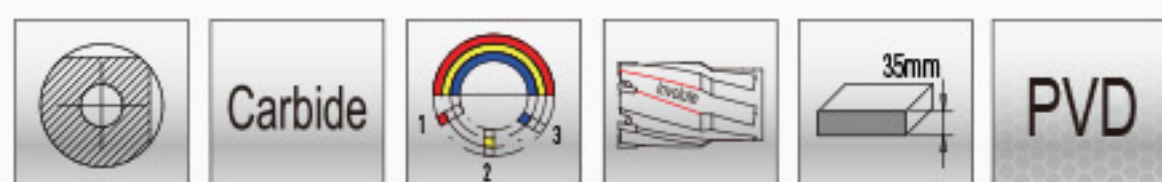
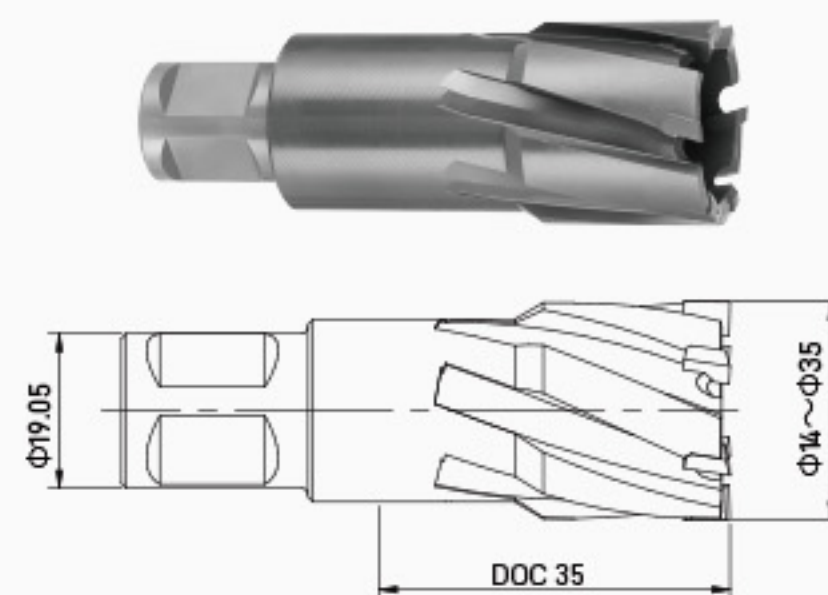

单位(Unit): mm

型号 MODEL	规格 SPECIFICATION	型号 MODEL	规格 SPECIFICATION	型号 MODEL	规格 SPECIFICATION	型号 MODEL	规格 SPECIFICATION
DNTX-30140EX6	14*35	DNTX-30200EX6	20*35	DNTX-30260EX6	26*35	DNTX-30320EX6	32*35
DNTX-30160EX6	16*35	DNTX-30220EX6	22*35	DNTX-30280EX6	28*35		
DNTX-30180EX6	18*35	DNTX-30240EX6	24*35	DNTX-30300EX6	30*35		

- 直角柄型, 有稳固的夹持力, 更好的保证钻孔稳定性与钻孔精度;
- 专用硬质合金刀片, 分层及低摩擦力切削几何;
- 适合多种磁座钻机、钻床等设备上钻孔与环形槽加工;
- 可涂层;
- Weldon shank, with more stable clamping force, better stability for drilling and better precision of holes;
- Special carbide tips with layered and low friction cutting geometry;
- Applicable to drilling and process of annular groove on various magnetic drilling machines and press;
- PVD;

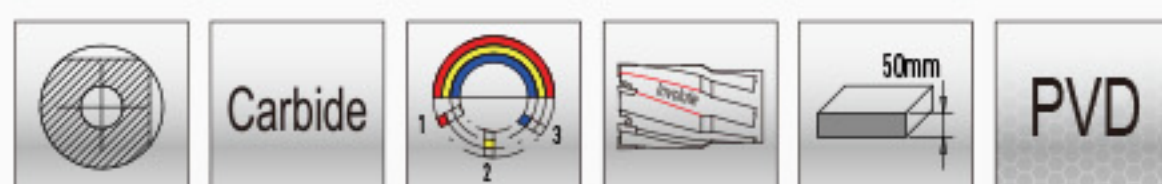
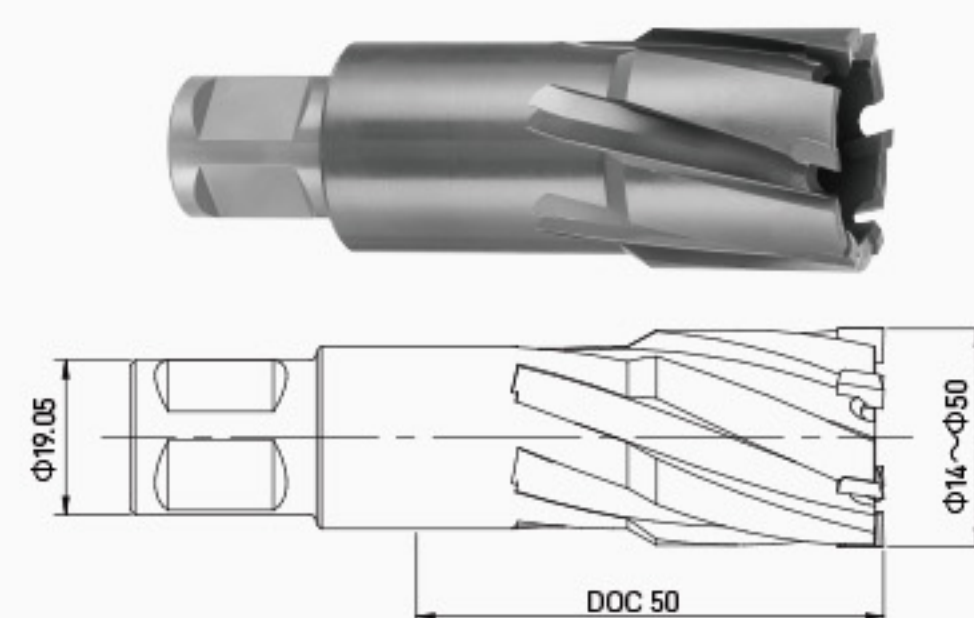

单位(Unit): mm

型号 MODEL	规格 SPECIFICATION	型号 MODEL	规格 SPECIFICATION	型号 MODEL	规格 SPECIFICATION	型号 MODEL	规格 SPECIFICATION
DNTX-40140EX6	14*50	DNTX-40200EX6	20*50	DNTX-40260EX6	26*50	DNTX-40320EX6	32*50
DNTX-40160EX6	16*50	DNTX-40220EX6	22*50	DNTX-40280EX6	28*50		
DNTX-40180EX6	18*50	DNTX-40240EX6	24*50	DNTX-40300EX6	30*50		

## 选配件 OPTIONAL ACCESSORIES

匹配顶针 MATCHING PILOT PIN				推荐钻机 RECOMMENDED MAGNETIC DRILLING MACHINE		
钻头直径 DIAMETER	型号 MODEL	规格 SPECIFICATION	顶针 PILOT PIN	钻头直径 DIAMETER	钻机型号 MAGNETIC DRILLING MACHINE	匹配夹具 MATCHING TOOL HOLDER
14-17	DPB-62090	6.34*90		14-17	DX-35	—
18-32	DPB-81090	7.98*90		18-32	DX-35	—



# DNTX CARBIDE TIPPED ANNULAR CUTTER WITH X-TYPE WELDON SHANK 硬质合金X型直角柄钢板钻

- 直角柄型, 有稳固的夹持力, 更好的保证钻孔稳定性与钻孔精度;
- 专用硬质合金刀片, 分层及低摩擦力切削几何;
- 适合多种磁座钻机、钻床等设备上钻孔与环形槽加工;
- Weldon shank, with more stable clamping force, better stability for drilling and better precision of holes;
- Special carbide tips with layered and low friction cutting geometry
- Applicable to drilling and process of annular groove on various magnetic drilling machines and press.

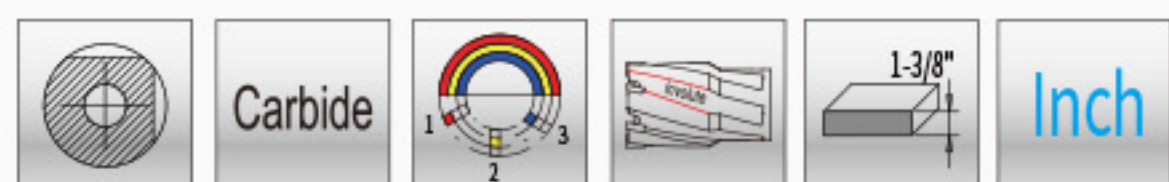
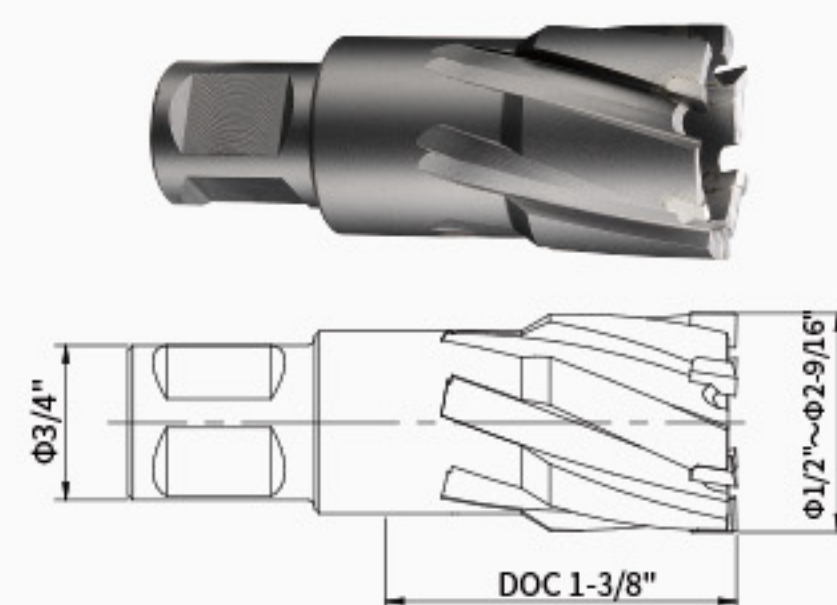

单位(Unit): inch

型号 MODEL	规格 SPECIFICATION	型号 MODEL	规格 SPECIFICATION	型号 MODEL	规格 SPECIFICATION	型号 MODEL	规格 SPECIFICATION
DNTX-C0437	7/16**1-3/8"	DNTX-C1000	1**1-3/8"	DNTX-C1562	1-9/16**1-3/8"	DNTX-C2125	2-1/8**1-3/8"
DNTX-C0500	1/2**1-3/8"	DNTX-C1062	1-1/16**1-3/8"	DNTX-C1625	1-5/8**1-3/8"	DNTX-C2187	2-3/16**1-3/8"
DNTX-C0562	9/16**1-3/8"	DNTX-C1125	1-1/8**1-3/8"	DNTX-C1687	1-11/16**1-3/8"	DNTX-C2250	2-1/4**1-3/8"
DNTX-C0625	5/8**1-3/8"	DNTX-C1187	1-3/16**1-3/8"	DNTX-C1750	1-3/4**1-3/8"	DNTX-C2312	2-5/16**1-3/8"
DNTX-C0687	11/16**1-3/8"	DNTX-C1250	1-1/4**1-3/8"	DNTX-C1812	1-13/16**1-3/8"	DNTX-C2375	2-3/8**1-3/8"
DNTX-C0750	3/4**1-3/8"	DNTX-C1312	1-5/16**1-3/8"	DNTX-C1875	1-7/8**1-3/8"	DNTX-C2437	2-7/16**1-3/8"
DNTX-C0812	13/16**1-3/8"	DNTX-C1375	1-3/8**1-3/8"	DNTX-C1937	1-15/16**1-3/8"	DNTX-C2500	2-1/2**1-3/8"
DNTX-C0875	7/8**1-3/8"	DNTX-C1437	1-7/16**1-3/8"	DNTX-C2000	2**1-3/8"	DNTX-C2562	2-9/16**1-3/8"
DNTX-C0937	15/16**1-3/8"	DNTX-C1500	1-1/2**1-3/8"	DNTX-C2062	2-1/16**1-3/8"		

公制规格详见P457 METRIC SIZE ON P457

## 选配件 OPTIONAL ACCESSORIES

匹配顶针 MATCHING PILOT PIN				推荐钻机 RECOMMENDED MAGNETIC DRILLING MACHINE		
钻头直径 DIAMETER	型号 MODEL	规格 SPECIFICATION	顶针 PILOT PIN	钻头直径 DIAMETER	钻机型号 MAGNETIC DRILLING MACHING	匹配夹具 MATCHING TOOL HOLDER
7/16"	DPB-42090	4.75*90		7/16"	DX-35	—
1/2"-11/16"	DPB-62090	6.34*90		1/2"-11/16"	DX-35	—
3/4"-2-9/16"	DPB-81090	7.98*90			DX-35	—
					DX-60	DJXY-50D-MT3
					DX-120	DJXY-50X-MT4



# DNTX CARBIDE TIPPED ANNULAR CUTTER WITH X-TYPE WELDON SHANK 硬质合金X型直角柄钢板钻

- 直角柄型, 有稳固的夹持力, 更好的保证钻孔稳定性与钻孔精度;
- 专用硬质合金刀片, 分层及低摩擦力切削几何;
- 适合多种磁座钻机、钻床等设备上钻孔与环形槽加工;
- Weldon shank, with more stable clamping force, better stability for drilling and better precision of holes;
- Special carbide tips with layered and low friction cutting geometry
- Applicable to drilling and process of annular groove on various magnetic drilling machines and press.

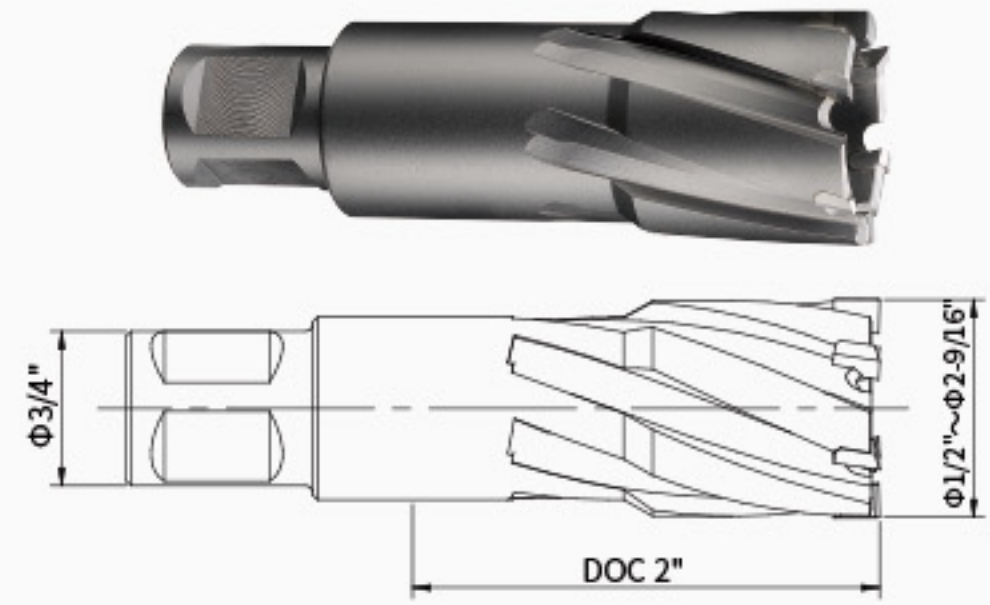

单位(Unit): inch

型号 MODEL	规格 SPECIFICATION	型号 MODEL	规格 SPECIFICATION	型号 MODEL	规格 SPECIFICATION	型号 MODEL	规格 SPECIFICATION
DNTX-D0437	7/16**2"	DNTX-D1000	1**2"	DNTX-D1562	1-9/16**2"	DNTX-D2125	2-1/8**2"
DNTX-D0500	1/2**2"	DNTX-D1062	1-1/16**2"	DNTX-D1625	1-5/8**2"	DNTX-D2187	2-3/16**2"
DNTX-D0562	9/16**2"	DNTX-D1125	1-1/8**2"	DNTX-D1687	1-11/16**2"	DNTX-D2250	2-1/4**2"
DNTX-D0625	5/8**2"	DNTX-D1187	1-3/16**2"	DNTX-D1750	1-3/4**2"	DNTX-D2312	2-5/16**2"
DNTX-D0687	11/16**2"	DNTX-D1250	1-1/4**2"	DNTX-D1812	1-13/16**2"	DNTX-D2375	2-3/8**2"
DNTX-D0750	3/4**2"	DNTX-D1312	1-5/16**2"	DNTX-D1875	1-7/8**2"	DNTX-D2437	2-7/16**2"
DNTX-D0812	13/16**2"	DNTX-D1375	1-3/8**2"	DNTX-D1937	1-15/16**2"	DNTX-D2500	2-1/2**2"
DNTX-D0875	7/8**2"	DNTX-D1437	1-7/16**2"	DNTX-D2000	2**2"	DNTX-D2562	2-9/16**2"
DNTX-D0937	15/16**2"	DNTX-D1500	1-1/2**2"	DNTX-D2062	2-1/16**2"		

公制规格详见P458 METRIC SIZE ON P458

## 选配件 OPTIONAL ACCESSORIES

匹配顶针 MATCHING PILOT PIN				推荐钻机 RECOMMENDED MAGNETIC DRILLING MACHINE		
钻头直径 DIAMETER	型号 MODEL	规格 SPECIFICATION	顶针 PILOT PIN	钻头直径 DIAMETER	钻机型号 MAGNETIC DRILLING MACHING	匹配夹具 MATCHING TOOL HOLDER
7/16"	DPB-42102	4.75*102		7/16"	DX-35	—
1/2"-11/16"	DPB-62102	6.34*102		1/2"-11/16"	DX-35	—
3/4"-2-9/16"	DPB-81103	7.98*103			DX-35	—
					DX-60	DJXY-50D-MT3
					DX-120	DJXY-50X-MT4



# DNTX CARBIDE TIPPED ANNULAR CUTTER WITH X-TYPE WELDON SHANK 硬质合金X型直角柄钢板钻

- 直角柄型, 有稳固的夹持力, 更好的保证钻孔稳定性与钻孔精度;
- 专用硬质合金刀片, 分层及低摩擦力切削几何;
- 适合多种磁座钻机、钻床等设备上钻孔与环形槽加工;
- Weldon shank, with more stable clamping force, better stability for drilling and better precision of holes;
- Special carbide tips with layered and low friction cutting geometry
- Applicable to drilling and process of annular groove on various magnetic drilling machines and press.



单位(Unit): inch

型号 MODEL	规格 SPECIFICATION	型号 MODEL	规格 SPECIFICATION	型号 MODEL	规格 SPECIFICATION	型号 MODEL	规格 SPECIFICATION
DNTX-E0562	9/16**3"	DNTX-E1125	1-1/8**3"	DNTX-E1687	1-11/16**3"	DNTX-E2250	2-1/4**3"
DNTX-E0625	5/8**3"	DNTX-E1187	1-3/16**3"	DNTX-E1750	1-3/4**3"	DNTX-E2312	2-5/16**3"
DNTX-E0687	11/16**3"	DNTX-E1250	1-1/4**3"	DNTX-E1812	1-13/16**3"	DNTX-E2375	2-3/8**3"
DNTX-E0750	3/4**3"	DNTX-E1312	1-5/16**3"	DNTX-E1875	1-7/8**3"	DNTX-E2437	2-7/16**3"
DNTX-E0812	13/16**3"	DNTX-E1375	1-3/8**3"	DNTX-E1937	1-15/16**3"	DNTX-E2500	2-1/2**3"
DNTX-E0875	7/8**3"	DNTX-E1437	1-7/16**3"	DNTX-E2000	2**3"	DNTX-E2562	2-9/16**3"
DNTX-E0937	15/16**3"	DNTX-E1500	1-1/2**3"	DNTX-E2062	2-1/16**3"		
DNTX-E1000	1**3"	DNTX-E1562	1-9/16**3"	DNTX-E2125	2-1/8**3"		
DNTX-E1062	1-1/16**3"	DNTX-E1625	1-5/8**3"	DNTX-E2187	2-3/16**3"		

公制规格详见P459 METRIC SIZE ON P459

## 选配件 OPTIONAL ACCESSORIES

匹配顶针 MATCHING PILOT PIN				推荐钻机 RECOMMENDED MAGNETIC DRILLING MACHINE		
钻头直径 DIAMETER	型号 MODEL	规格 SPECIFICATION	顶针 PILOT PIN	钻头直径 DIAMETER	钻机型号 MAGNETIC DRILLING MACHING	匹配夹具 MATCHING TOOL HOLDER
Φ9/16"-5/8"	DPB-62130	6.34*130		Φ9/16"-5/8"	DX-60	DJXY-75X-MT3
11/16"-2-9/16"	DPB-81130	7.98*130		11/16"-2-9/16"	DX-60	DJXY-75X-MT3
					DX-120	DJXY-75X-MT4



# DNTX CARBIDE TIPPED ANNULAR CUTTER WITH X-TYPE WELDON SHANK 硬质合金X型直角柄钢板钻

- 直角柄型, 有稳固的夹持力, 更好的保证钻孔稳定性与钻孔精度;
- 专用硬质合金刀片, 分层及低摩擦力切削几何;
- 适合多种磁座钻机、钻床等设备上钻孔与环形槽加工;
- Weldon shank, with more stable clamping force, better stability for drilling and better precision of holes;
- Special carbide tips with layered and low friction cutting geometry
- Applicable to drilling and process of annular groove on various magnetic drilling machines and press.

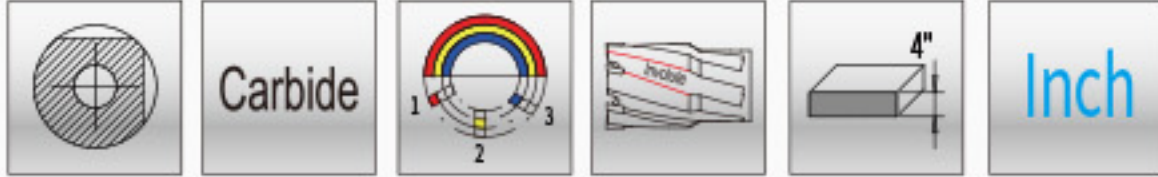
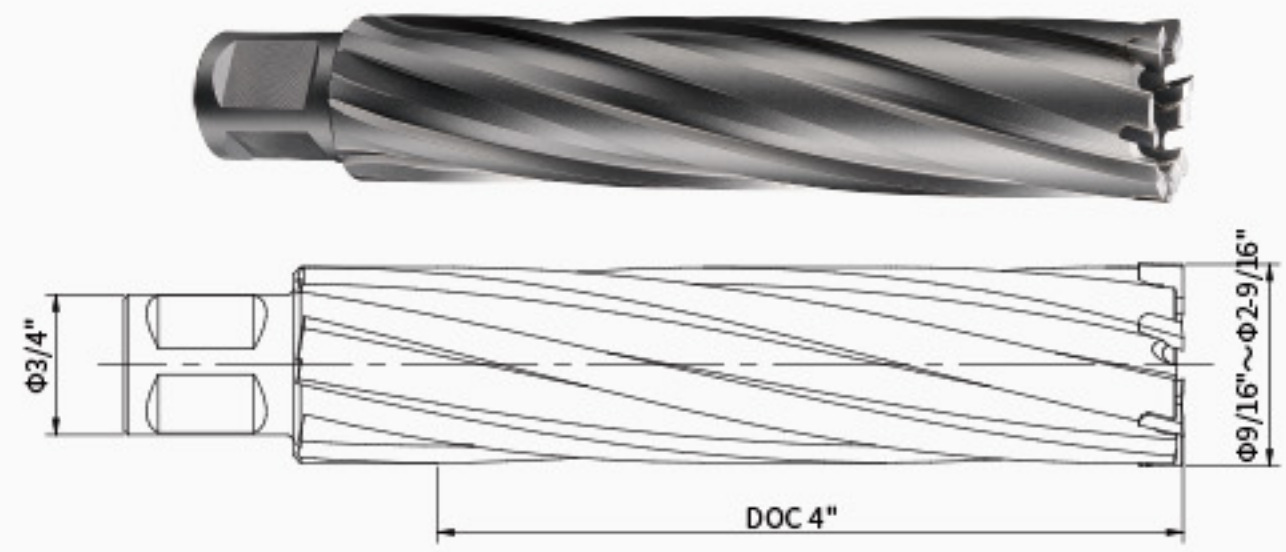

单位(Unit): inch

型号 MODEL	规格 SPECIFICATION	型号 MODEL	规格 SPECIFICATION	型号 MODEL	规格 SPECIFICATION	型号 MODEL	规格 SPECIFICATION
DNTX-F0562	9/16**4"	DNTX-F1125	1-1/8**4"	DNTX-F1687	1-11/16**4"	DNTX-F2250	2-1/4**4"
DNTX-F0625	5/8**4"	DNTX-F1187	1-3/16**4"	DNTX-F1750	1-3/4**4"	DNTX-F2312	2-5/16**4"
DNTX-F0687	11/16**4"	DNTX-F1250	1-1/4**4"	DNTX-F1812	1-13/16**4"	DNTX-F2375	2-3/8**4"
DNTX-F0750	3/4**4"	DNTX-F1312	1-5/16**4"	DNTX-F1875	1-7/8**4"	DNTX-F2437	2-7/16**4"
DNTX-F0812	13/16**4"	DNTX-F1375	1-3/8**4"	DNTX-F1937	1-15/16**4"	DNTX-F2500	2-1/2**4"
DNTX-F0875	7/8**4"	DNTX-F1437	1-7/16**4"	DNTX-F2000	2**4"	DNTX-F2562	2-9/16**4"
DNTX-F0937	15/16**4"	DNTX-F1500	1-1/2**4"	DNTX-F2062	2-1/16**4"		
DNTX-F1000	1**4"	DNTX-F1562	1-9/16**4"	DNTX-F2125	2-1/8**4"		
DNTX-F1062	1-1/16**4"	DNTX-F1625	1-5/8**4"	DNTX-F2187	2-3/16**4"		

公制规格详见P460 METRIC SIZE ON P460

## 选配件 OPTIONAL ACCESSORIES

匹配顶针 MATCHING PILOT PIN				推荐钻机 RECOMMENDED MAGNETIC DRILLING MACHINE		
钻头直径 DIAMETER	型号 MODEL	规格 SPECIFICATION	顶针 PILOT PIN	钻头直径 DIAMETER	钻机型号 MAGNETIC DRILLING MACHING	匹配夹具 MATCHING TOOL HOLDER
Φ9/16"-5/8"	DPB-62160	6.34*160		Φ9/16"-5/8"	DX-120	DJXY-100X-MT4
11/16"-2-9/16"	DPB-81160	7.98*160		11/16"-2-9/16"		



# DNTX CARBIDE TIPPED ANNULAR CUTTER WITH X-TYPE WELDON SHANK 硬质合金X型直角柄钢板钻

- 直角柄型, 有稳固的夹持力, 更好的保证钻孔稳定性与钻孔精度;
- 专用硬质合金刀片, 分层及低摩擦力切削几何;
- 适合多种磁座钻机、钻床等设备上钻孔与环形槽加工;
- Weldon shank, with more stable clamping force, better stability for drilling and better precision of holes;
- Special carbide tips with layered and low friction cutting geometry
- Applicable to drilling and process of annular groove on various magnetic drilling machines and press.

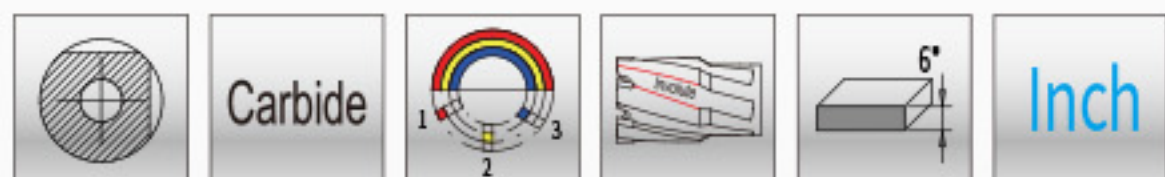
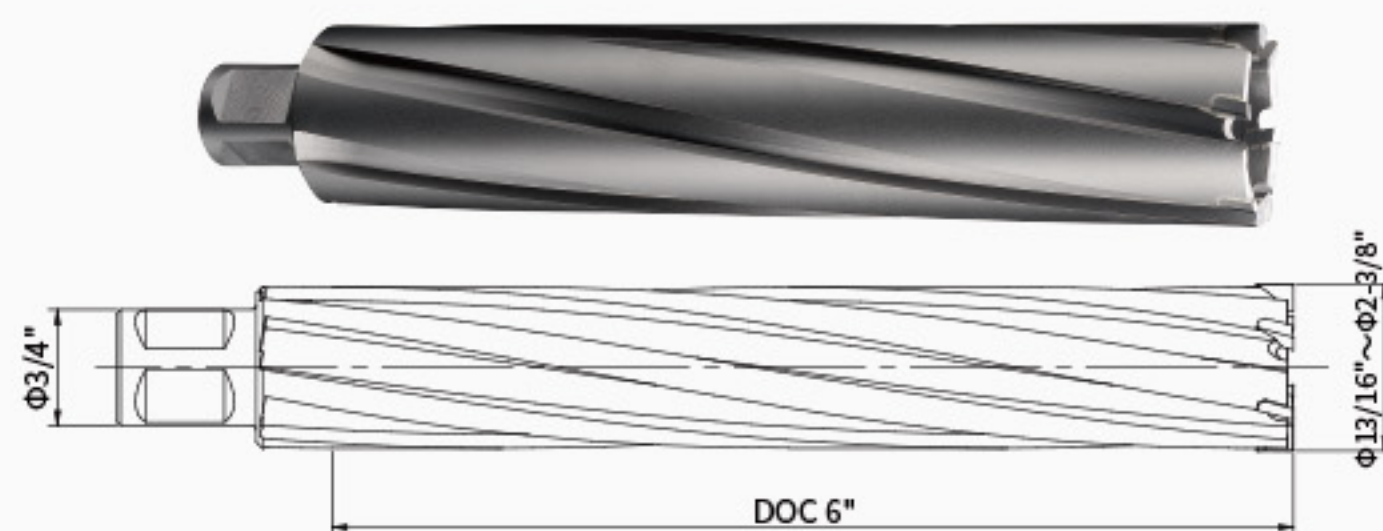

单位(Unit): inch

型号 MODEL	规格 SPECIFICATION	型号 MODEL	规格 SPECIFICATION	型号 MODEL	规格 SPECIFICATION	型号 MODEL	规格 SPECIFICATION
DNTX-G0812	13/16**6"	DNTX-G1250	1-1/4**6"	DNTX-G1687	1-11/16**6"	DNTX-G2125	2-1/8**6"
DNTX-G0875	7/8**6"	DNTX-G1312	1-5/16**6"	DNTX-G1750	1-3/4**6"	DNTX-G2187	2-3/16**6"
DNTX-G0937	15/16**6"	DNTX-G1375	1-3/8**6"	DNTX-G1812	1-13/16**6"	DNTX-G2250	2-1/4**6"
DNTX-G1000	1**6"	DNTX-G1437	1-7/16**6"	DNTX-G1875	1-7/8**6"	DNTX-G2312	2-5/16**6"
DNTX-G1062	1-1/16**6"	DNTX-G1500	1-1/2**6"	DNTX-G1937	1-15/16**6"	DNTX-G2375	2-3/8**6"
DNTX-G1125	1-1/8**6"	DNTX-G1562	1-9/16**6"	DNTX-G2000	2**6"		
DNTX-G1187	1-3/16**6"	DNTX-G1625	1-5/8**6"	DNTX-G2062	2-1/16**6"		

公制规格详见P461 METRIC SIZE ON P461

## 选配件 OPTIONAL ACCESSORIES

匹配顶针 MATCHING PILOT PIN			
钻头直径 DIAMETER	型号 MODEL	规格 SPECIFICATION	顶针 PILOT PIN
13/16"-2-3/8"	DPT-82205	7.98*205	

顶针应用详见P635 PILOT PIN APPLICATION ON P635