

# DNAX HSS-PM ANNULAR CUTTER WITH X-TYPE WELDON SHANK 粉末高速钢X型直角柄钢板钻

- 直角柄型, 适合各种钻机接口;
- 粉末高速钢, 分层及低摩擦力切削几何;
- 适合多种磁座钻机、钻床等设备上钻孔与环形槽加工;
- 可选TiAlN, TiN, AlCrN三种涂层, 提升性能;
- Weldon shank, suitable for various magnetic drilling machine;
- HSS-PM with layered and low friction cutting geometry;
- Applicable to hole drilling and process of annular flute on various magnetic drills and press.
- Choose TiAlN, TiN and AlCrN coatings to improve performance.

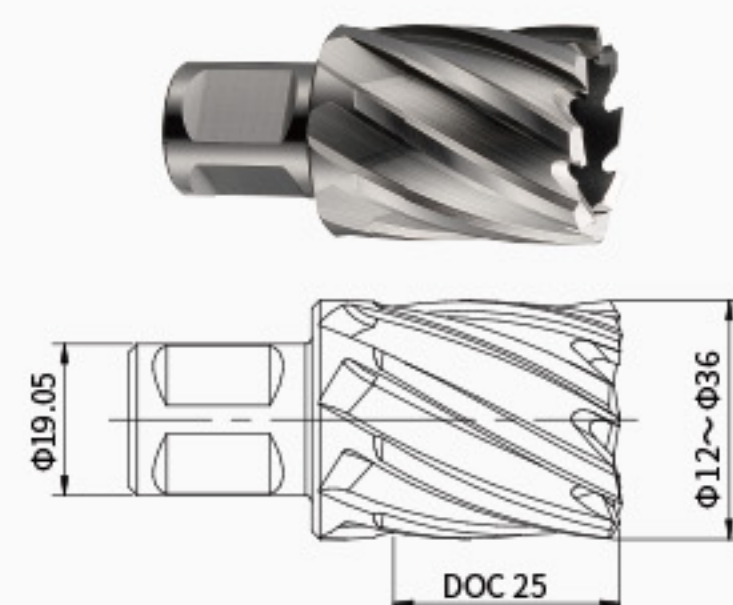

单位(Unit): mm

型号 MODEL	规格 SPECIFICATION	型号 MODEL	规格 SPECIFICATION	型号 MODEL	规格 SPECIFICATION	型号 MODEL	规格 SPECIFICATION
DNAX-20120	12*25	DNAX-20190	19*25	DNAX-20260	26*25	DNAX-20330	33*25
DNAX-20130	13*25	DNAX-20200	20*25	DNAX-20270	27*25	DNAX-20340	34*25
DNAX-20140	14*25	DNAX-20210	21*25	DNAX-20280	28*25	DNAX-20350	35*25
DNAX-20150	15*25	DNAX-20220	22*25	DNAX-20290	29*25	DNAX-20360	36*25
DNAX-20160	16*25	DNAX-20230	23*25	DNAX-20300	30*25		
DNAX-20170	17*25	DNAX-20240	24*25	DNAX-20310	31*25		
DNAX-20180	18*25	DNAX-20250	25*25	DNAX-20320	32*25		

## 选配件 OPTIONAL ACCESSORIES

匹配顶针 MATCHING PILOT PIN				推荐钻机 RECOMMENDED MAGNETIC DRILLING MACHINE		
钻头直径 DIAMETER	型号 MODEL	规格 SPECIFICATION	顶针 PILOT PIN	钻头直径 DIAMETER	钻机型号 MAGNETIC DRILLING MACHING	匹配夹具 MATCHING TOOL HOLDER
12-36	DPB-62077	6.34*77			DX-35	—
					DX-60	DJXY-50D-MT3
					DX-120	DJXY-50X-MT4



# DNAX HSS-PM ANNULAR CUTTER WITH X-TYPE WELDON SHANK 粉末高速钢X型直角柄钢板钻

- 直角柄型, 适合各种钻机接口;
- 粉末高速钢, 分层及低摩擦力切削几何;
- 适合多种磁座钻机、钻床等设备上钻孔与环形槽加工;
- 可选TiAlN, TiN, AlCrN三种涂层, 提升性能;
- Weldon shank, suitable for various magnetic drilling machine;
- HSS-PM with layered and low friction cutting geometry;
- Applicable to hole drilling and process of annular flute on various magnetic drills and press.
- Choose TiAlN, TiN and AlCrN coatings to improve performance.

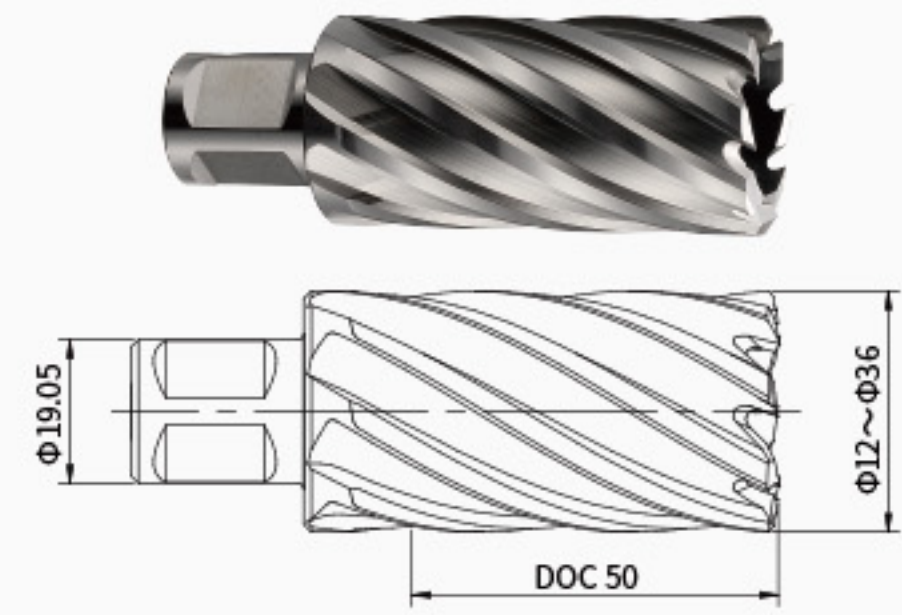

单位(Unit): mm

型号 MODEL	规格 SPECIFICATION	型号 MODEL	规格 SPECIFICATION	型号 MODEL	规格 SPECIFICATION	型号 MODEL	规格 SPECIFICATION
DNAX-40120	12*50	DNAX-40190	19*50	DNAX-40260	26*50	DNAX-40330	33*50
DNAX-40130	13*50	DNAX-40200	20*50	DNAX-40270	27*50	DNAX-40340	34*50
DNAX-40140	14*50	DNAX-40210	21*50	DNAX-40280	28*50	DNAX-40350	35*50
DNAX-40150	15*50	DNAX-40220	22*50	DNAX-40290	29*50	DNAX-40360	36*50
DNAX-40160	16*50	DNAX-40230	23*50	DNAX-40300	30*50		
DNAX-40170	17*50	DNAX-40240	24*50	DNAX-40310	31*50		
DNAX-40180	18*50	DNAX-40250	25*50	DNAX-40320	32*50		

## 选配件 OPTIONAL ACCESSORIES

匹配顶针 MATCHING PILOT PIN				推荐钻机 RECOMMENDED MAGNETIC DRILLING MACHINE		
钻头直径 DIAMETER	型号 MODEL	规格 SPECIFICATION	顶针 PILOT PIN	钻头直径 DIAMETER	钻机型号 MAGNETIC DRILLING MACHING	匹配夹具 MATCHING TOOL HOLDER
12-36	DPB-62102	6.34*102		12-36	DX-35 DX-60 DX-120	— DJXY-50D-MT3 DJXY-50X-MT4

