

DNFX HSS ANNULAR CUTTER WITH X-TYPE WELDON SHANK 高速钢X型直角柄钢板钻

- 直角柄型, 有稳固的夹持力, 更好的保证钻孔稳定性与钻孔精度;
- 高速钢, 分层及低摩擦力切削几何;
- 适合多种磁座钻机、钻床等设备上钻孔与环形槽加工;
- 可选TiAlN, TiN, AlCrN三种涂层, 提升性能;
- Weldon shank with more stable clamping, better to ensure the stability and accuracy of drilling;
- HSS with layered and low friction cutting geometry;
- Applicable to hole cutting and process of annular flute on various magnetic drills and press.
- Choose TiAlN, TiN and AlCrN coatings to improve performance.

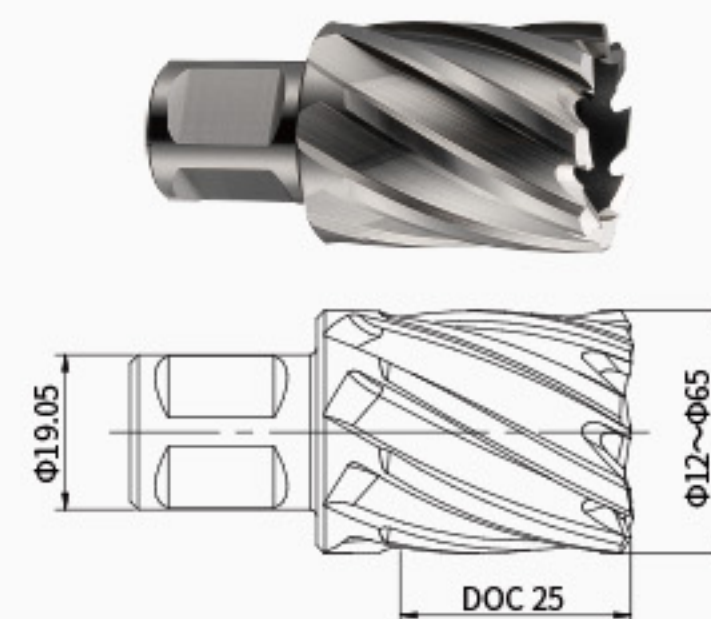

单位(Unit): mm

型号 MODEL	规格 SPECIFICATION	型号 MODEL	规格 SPECIFICATION	型号 MODEL	规格 SPECIFICATION	型号 MODEL	规格 SPECIFICATION
DNFX-20120	12*25	DNFX-20280	28*25	DNFX-20440	44*25	DNFX-20600	60*25
DNFX-20130	13*25	DNFX-20290	29*25	DNFX-20450	45*25	DNFX-20610	61*25
DNFX-20140	14*25	DNFX-20300	30*25	DNFX-20460	46*25	DNFX-20620	62*25
DNFX-20150	15*25	DNFX-20310	31*25	DNFX-20470	47*25	DNFX-20630	63*25
DNFX-20160	16*25	DNFX-20320	32*25	DNFX-20480	48*25	DNFX-20640	64*25
DNFX-20170	17*25	DNFX-20330	33*25	DNFX-20490	49*25	DNFX-20650	65*25
DNFX-20180	18*25	DNFX-20340	34*25	DNFX-20500	50*25		
DNFX-20190	19*25	DNFX-20350	35*25	DNFX-20510	51*25		
DNFX-20200	20*25	DNFX-20360	36*25	DNFX-20520	52*25		
DNFX-20210	21*25	DNFX-20370	37*25	DNFX-20530	53*25		
DNFX-20220	22*25	DNFX-20380	38*25	DNFX-20540	54*25		
DNFX-20230	23*25	DNFX-20390	39*25	DNFX-20550	55*25		
DNFX-20240	24*25	DNFX-20400	40*25	DNFX-20560	56*25		
DNFX-20250	25*25	DNFX-20410	41*25	DNFX-20570	57*25		
DNFX-20260	26*25	DNFX-20420	42*25	DNFX-20580	58*25		
DNFX-20270	27*25	DNFX-20430	43*25	DNFX-20590	59*25		

选配件 OPTIONAL ACCESSORIES

匹配顶针 MATCHING PILOT PIN				推荐钻机 RECOMMENDED MAGNETIC DRILLING MACHINE		
钻头直径 DIAMETER	型号 MODEL	规格 SPECIFICATION	顶针 PILOT PIN	钻头直径 DIAMETER	钻机型号 MAGNETIC DRILLING MACHING	匹配夹具 MATCHING TOOL HOLDER
12-65	DPB-62077	6.34*77		12-65	DX-35	—
				12-65	DX-60	DJXY-50D-MT3
				12-65	DX-120	DJXY-50X-MT4

DNFX HSS ANNULAR CUTTER WITH X-TYPE WELDON SHANK 高速钢X型直角柄钢板钻

- 直角柄型, 有稳固的夹持力, 更好的保证钻孔稳定性与钻孔精度;
- 高速钢, 分层及低摩擦力切削几何;
- 适合多种磁座钻机、钻床等设备上钻孔与环形槽加工;
- 可选TiAlN, TiN, AlCrN三种涂层, 提升性能;
- Weldon shank with more stable clamping, better to ensure the stability and accuracy of drilling;
- HSS with layered and low friction cutting geometry;
- Applicable to hole cutting and process of annular flute on various magnetic drills and press.
- Choose TiAlN, TiN and AlCrN coatings to improve performance.

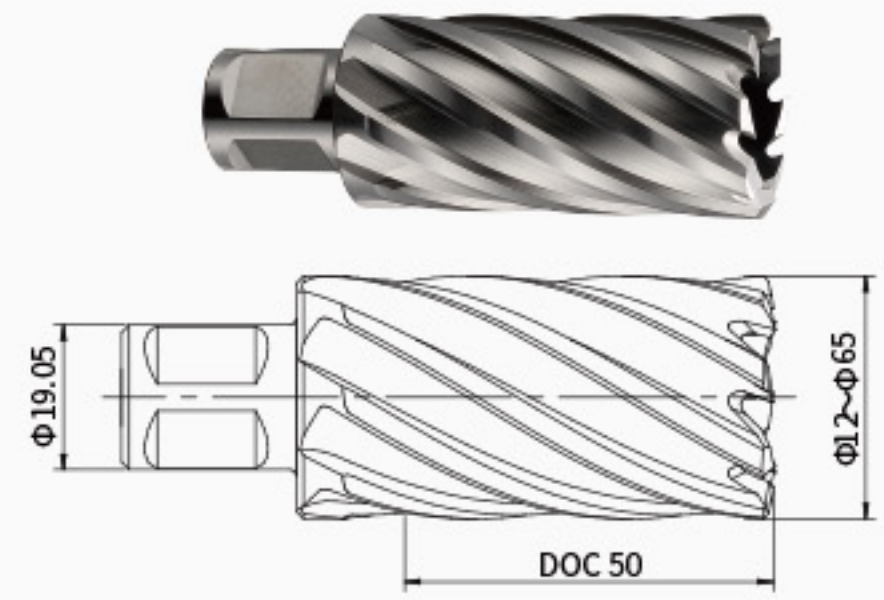

单位(Unit): mm

型号 MODEL	规格 SPECIFICATION	型号 MODEL	规格 SPECIFICATION	型号 MODEL	规格 SPECIFICATION	型号 MODEL	规格 SPECIFICATION
DNFX-40120	12*50	DNFX-40280	28*50	DNFX-40440	44*50	DNFX-40600	60*50
DNFX-40130	13*50	DNFX-40290	29*50	DNFX-40450	45*50	DNFX-40610	61*50
DNFX-40140	14*50	DNFX-40300	30*50	DNFX-40460	46*50	DNFX-40620	62*50
DNFX-40150	15*50	DNFX-40310	31*50	DNFX-40470	47*50	DNFX-40630	63*50
DNFX-40160	16*50	DNFX-40320	32*50	DNFX-40480	48*50	DNFX-40640	64*50
DNFX-40170	17*50	DNFX-40330	33*50	DNFX-40490	49*50	DNFX-40650	65*50
DNFX-40180	18*50	DNFX-40340	34*50	DNFX-40500	50*50		
DNFX-40190	19*50	DNFX-40350	35*50	DNFX-40510	51*50		
DNFX-40200	20*50	DNFX-40360	36*50	DNFX-40520	52*50		
DNFX-40210	21*50	DNFX-40370	37*50	DNFX-40530	53*50		
DNFX-40220	22*50	DNFX-40380	38*50	DNFX-40540	54*50		
DNFX-40230	23*50	DNFX-40390	39*50	DNFX-40550	55*50		
DNFX-40240	24*50	DNFX-40400	40*50	DNFX-40560	56*50		
DNFX-40250	25*50	DNFX-40410	41*50	DNFX-40570	57*50		
DNFX-40260	26*0	DNFX-40420	42*50	DNFX-40580	58*50		
DNFX-40270	27*50	DNFX-40430	43*50	DNFX-40590	59*50		

选配件 OPTIONAL ACCESSORIES

匹配顶针 MATCHING PILOT PIN				推荐钻机 RECOMMENDED MAGNETIC DRILLING MACHINE		
钻头直径 DIAMETER	型号 MODEL	规格 SPECIFICATION	顶针 PILOT PIN	钻头直径 DIAMETER	钻机型号 MAGNETIC DRILLING MACHING	匹配夹具 MATCHING TOOL HOLDER
12-65	DPB-62102	6.34*102			DX-35	—
					DX-60	DJXY-50D-MT3
					DX-120	DJXY-50X-MT4