

DNHC HSS ANNULAR CUTTER WITH C-TYPE UNIVERSAL SHANK 高速钢C型通用柄钢板钻

- 通用柄型, 适合各种钻机接口;
- 超硬高速钢, 分层及低摩擦力切削几何;
- 适合多种磁座钻机、钻床等设备上钻孔与环形槽加工;
- 可选TiAlN, TiN, AlCrN三种涂层, 提升性能;
- Universal shank, suitable for various magnetic drilling machine;
- HSS-E with layered and low friction cutting geometry;
- Applicable to hole drilling and process of annular flute on various magnetic drills and press;
- Choose TiAlN, TiN and AlCrN coatings to improve performance.

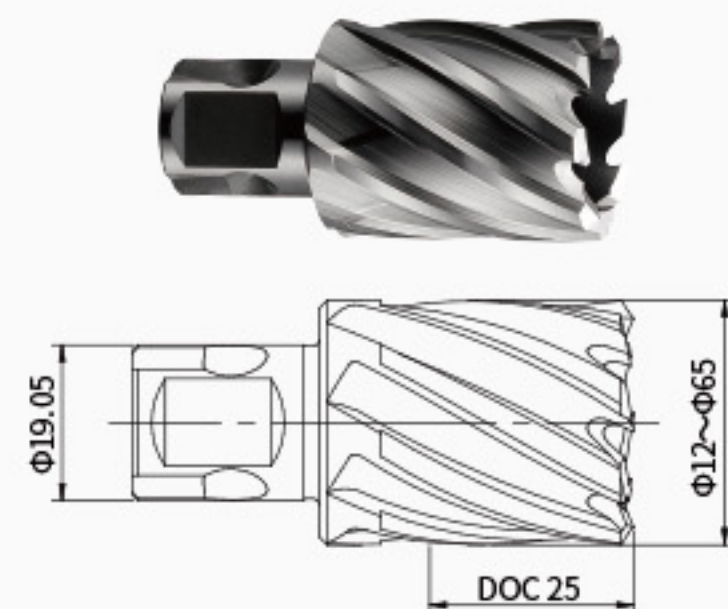

单位(Unit): mm

型号 MODEL	规格 SPECIFICATION	型号 MODEL	规格 SPECIFICATION	型号 MODEL	规格 SPECIFICATION	型号 MODEL	规格 SPECIFICATION
DNHC-20120	12*25	DNHC-20250	25*25	DNHC-20420	42*25	DNHC-20600	60*25
DNHC-20130	13*25	DNHC-20260	26*25	DNHC-20430	43*25	DNHC-20610	61*25
DNHC-20140	14*25	DNHC-20265	26.5*25	DNHC-20440	44*25	DNHC-20620	62*25
DNHC-20150	15*25	DNHC-20270	27*25	DNHC-20450	45*25	DNHC-20630	63*25
DNHC-20160	16*25	DNHC-20280	28*25	DNHC-20460	46*25	DNHC-20640	64*25
DNHC-20170	17*25	DNHC-20290	29*25	DNHC-20470	47*25	DNHC-20650	65*25
DNHC-20180	18*25	DNHC-20300	30*25	DNHC-20480	48*25		
DNHC-20185	18.5*25	DNHC-20310	31*25	DNHC-20490	49*25		
DNHC-20190	19*25	DNHC-20320	32*25	DNHC-20500	50*25		
DNHC-20200	20*25	DNHC-20330	33*25	DNHC-20510	51*25		
DNHC-20205	20.5*25	DNHC-20340	34*25	DNHC-20520	52*25		
DNHC-20210	21*25	DNHC-20350	35*25	DNHC-20530	53*25		
DNHC-20215	21.5*25	DNHC-20360	36*25	DNHC-20540	54*25		
DNHC-20220	22*25	DNHC-20370	37*25	DNHC-20550	55*25		
DNHC-20225	22.5*25	DNHC-20380	38*25	DNHC-20560	56*25		
DNHC-20230	23*25	DNHC-20390	39*25	DNHC-20570	57*25		
DNHC-20240	24*25	DNHC-20400	40*25	DNHC-20580	58*25		
DNHC-20245	24.5*25	DNHC-20410	41*25	DNHC-20590	59*25		

英制规格详见P547 INCH SIZE ON P547

选配件 OPTIONAL ACCESSORIES

匹配顶针 MATCHING PILOT PIN				推荐钻机 RECOMMENDED MAGNETIC DRILLING MACHINE		
钻头直径 DIAMETER	型号 MODEL	规格 SPECIFICATION	顶针 PILOT PIN	钻头直径 DIAMETER	钻机型号 MAGNETIC DRILLING MACHING	匹配夹具 MATCHING TOOL HOLDER
12-65	DPB-62077	6.34*77		12-65	DX-35	—
					DX-60	DJXY-50D-MT3
					DX-120	DJXY-50X-MT4

DNHC HSS ANNULAR CUTTER WITH C-TYPE UNIVERSAL SHANK 高速钢C型通用柄钢板钻

- 通用柄型, 适合各种钻机接口;
- 超硬高速钢, 分层及低摩擦力切削几何;
- 适合多种磁座钻机、钻床等设备上钻孔与环形槽加工;
- 可选TiAlN, TiN, AlCrN三种涂层, 提升性能;
- Universal shank, suitable for various magnetic drilling machine;
- HSS-E with layered and low friction cutting geometry;
- Applicable to hole drilling and process of annular flute on various magnetic drills and press;
- Choose TiAlN, TiN and AlCrN coatings to improve performance.

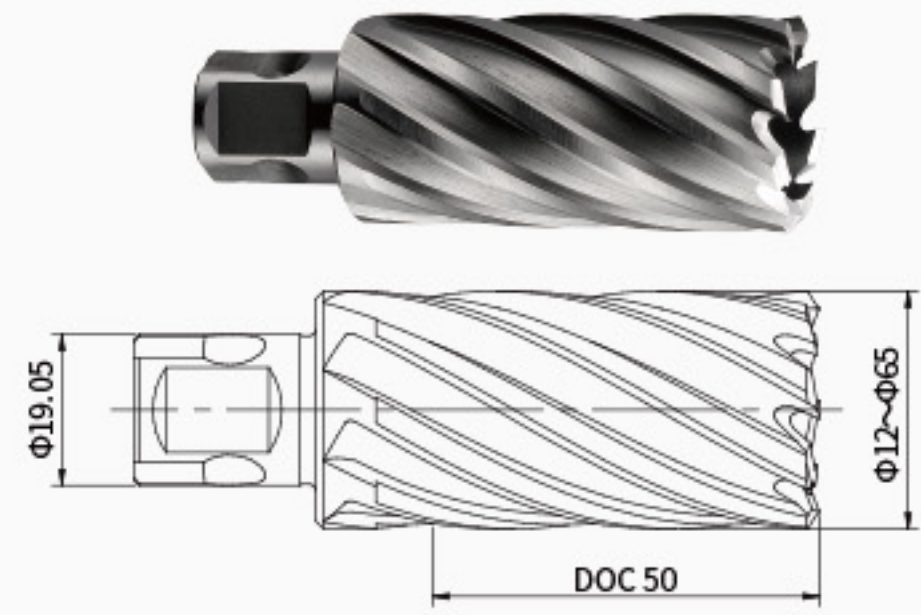

单位(Unit): mm

型号 MODEL	规格 SPECIFICATION	型号 MODEL	规格 SPECIFICATION	型号 MODEL	规格 SPECIFICATION	型号 MODEL	规格 SPECIFICATION
DNHC-40120	12*50	DNHC-40250	25*50	DNHC-40420	42*50	DNHC-40600	60*50
DNHC-40130	13*50	DNHC-40260	26*50	DNHC-40430	43*50	DNHC-40610	61*50
DNHC-40140	14*50	DNHC-40265	26.5*50	DNHC-40440	44*50	DNHC-40620	62*50
DNHC-40150	15*50	DNHC-40270	27*50	DNHC-40450	45*50	DNHC-40630	63*50
DNHC-40160	16*50	DNHC-40280	28*50	DNHC-40460	46*50	DNHC-40640	64*50
DNHC-40170	17*50	DNHC-40290	29*50	DNHC-40470	47*50	DNHC-40650	65*50
DNHC-40180	18*50	DNHC-40300	30*50	DNHC-40480	48*50		
DNHC-40185	18.5*50	DNHC-40310	31*50	DNHC-40490	49*50		
DNHC-40190	19*50	DNHC-40320	32*50	DNHC-40500	50*50		
DNHC-40200	20*50	DNHC-40330	33*50	DNHC-40510	51*50		
DNHC-40205	20.5*50	DNHC-40340	34*50	DNHC-40520	52*50		
DNHC-40210	21*50	DNHC-40350	35*50	DNHC-40530	53*50		
DNHC-40215	21.5*50	DNHC-40360	36*50	DNHC-40540	54*50		
DNHC-40220	22*50	DNHC-40370	37*50	DNHC-40550	55*50		
DNHC-40225	22.5*50	DNHC-40380	38*50	DNHC-40560	56*50		
DNHC-40230	23*50	DNHC-40390	39*50	DNHC-40570	57*50		
DNHC-40240	24*50	DNHC-40400	40*50	DNHC-40580	58*50		
DNHC-40245	24.5*50	DNHC-40410	41*50	DNHC-40590	59*50		

英制规格详见P548 INCH SIZE ON P548

选配件 OPTIONAL ACCESSORIES

匹配顶针 MATCHING PILOT PIN				推荐钻机 RECOMMENDED MAGNETIC DRILLING MACHINE		
钻头直径 DIAMETER	型号 MODEL	规格 SPECIFICATION	顶针 PILOT PIN	钻头直径 DIAMETER	钻机型号 MAGNETIC DRILLING MACHING	匹配夹具 MATCHING TOOL HOLDER
12-65	DPB-62102	6.34*102		12-65	DX-35	—
					DX-60	DJXY-50D-MT3
					DX-120	DJXY-50X-MT4

DNHC HSS ANNULAR CUTTER WITH C-TYPE UNIVERSAL SHANK 高速钢C型通用柄钢板钻

- 通用柄型, 适合各种钻机接口;
- 超硬高速钢, 分层及低摩擦力切削几何;
- 适合多种磁座钻机、钻床等设备上钻孔与环形槽加工;
- 可选TiAlN, TiN, AlCrN三种涂层, 提升性能;
- Universal shank, suitable for various magnetic drilling machine;
- HSS-E with layered and low friction cutting geometry;
- Applicable to hole drilling and process of annular flute on various magnetic drills and press;
- Choose TiAlN, TiN and AlCrN coatings to improve performance.

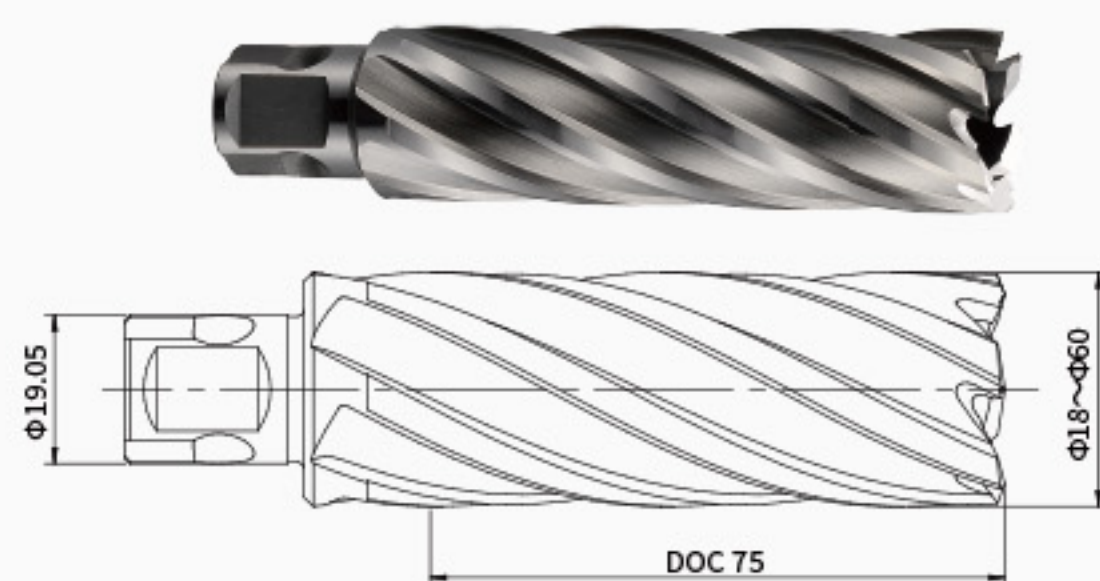

单位(Unit): mm

型号 MODEL	规格 SPECIFICATION	型号 MODEL	规格 SPECIFICATION	型号 MODEL	规格 SPECIFICATION	型号 MODEL	规格 SPECIFICATION
DNHC-50180	18*75	DNHC-50300	30*75	DNHC-50420	42*75	DNHC-50540	54*75
DNHC-50190	19*75	DNHC-50310	31*75	DNHC-50430	43*75	DNHC-50550	55*75
DNHC-50200	20*75	DNHC-50320	32*75	DNHC-50440	44*75	DNHC-50560	56*75
DNHC-50210	21*75	DNHC-50330	33*75	DNHC-50450	45*75	DNHC-50570	57*75
DNHC-50220	22*75	DNHC-50340	34*75	DNHC-50460	46*75	DNHC-50580	58*75
DNHC-50230	23*75	DNHC-50350	35*75	DNHC-50470	47*75	DNHC-50590	59*75
DNHC-50240	24*75	DNHC-50360	36*75	DNHC-50480	48*75	DNHC-50600	60*75
DNHC-50250	25*75	DNHC-50370	37*75	DNHC-50490	49*75		
DNHC-50260	26*75	DNHC-50380	38*75	DNHC-50500	50*75		
DNHC-50270	27*75	DNHC-50390	39*75	DNHC-50510	51*75		
DNHC-50280	28*75	DNHC-50400	40*75	DNHC-50520	52*75		
DNHC-50290	29*75	DNHC-50410	41*75	DNHC-50530	53*75		

英制规格详见P549 INCH SIZE ON P549

选配件 OPTIONAL ACCESSORIES

匹配顶针 MATCHING PILOT PIN				推荐钻机 RECOMMENDED MAGNETIC DRILLING MACHINE		
钻头直径 DIAMETER	型号 MODEL	规格 SPECIFICATION	顶针 PILOT PIN	钻头直径 DIAMETER	钻机型号 MAGNETIC DRILLING MACHING	匹配夹具 MATCHING TOOL HOLDER
18-60	DPB-81130	7.98*130		18-60	DX-60	DJXY-75X-MT3
					DX-120	DJXY-75X-MT4

DNHC HSS ANNULAR CUTTER WITH C-TYPE UNIVERSAL SHANK 高速钢C型通用柄钢板钻

- 通用柄型, 适合各种钻机接口;
- 超硬高速钢, 分层及低摩擦力切削几何;
- 适合多种磁座钻机、钻床等设备上钻孔与环形槽加工;
- 可选TiAlN, TiN, AlCrN三种涂层, 提升性能;
- Universal shank, suitable for various magnetic drilling machine;
- HSS-E with layered and low friction cutting geometry;
- Applicable to hole drilling and process of annular flute on various magnetic drills and press;
- Choose TiAlN, TiN and AlCrN coatings to improve performance.

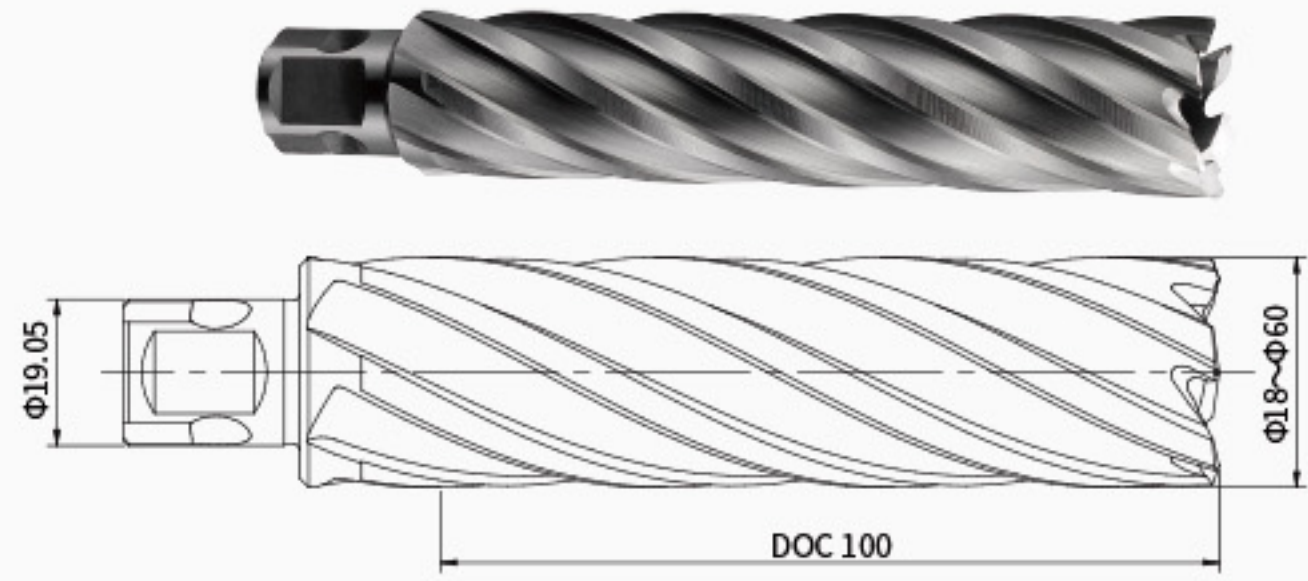

单位(Unit): mm

型号 MODEL	规格 SPECIFICATION	型号 MODEL	规格 SPECIFICATION	型号 MODEL	规格 SPECIFICATION	型号 MODEL	规格 SPECIFICATION
DNHC-60180	18*100	DNHC-60300	30*100	DNHC-60420	42*100	DNHC-60540	54*100
DNHC-60190	19*100	DNHC-60310	31*100	DNHC-60430	43*100	DNHC-60550	55*100
DNHC-60200	20*100	DNHC-60320	32*100	DNHC-60440	44*100	DNHC-60560	56*100
DNHC-60210	21*100	DNHC-60330	33*100	DNHC-60450	45*100	DNHC-60570	57*100
DNHC-60220	22*100	DNHC-60340	34*100	DNHC-60460	46*100	DNHC-60580	58*100
DNHC-60230	23*100	DNHC-60350	35*100	DNHC-60470	47*100	DNHC-60590	59*100
DNHC-60240	24*100	DNHC-60360	36*100	DNHC-60480	48*100	DNHC-60600	60*100
DNHC-60250	25*100	DNHC-60370	37*100	DNHC-60490	49*100		
DNHC-60260	26*100	DNHC-60380	38*100	DNHC-60500	50*100		
DNHC-60270	27*100	DNHC-60390	39*100	DNHC-60510	51*100		
DNHC-60280	28*100	DNHC-60400	40*100	DNHC-60520	52*100		
DNHC-60290	29*100	DNHC-60410	41*100	DNHC-60530	53*100		

英制规格详见P550 INCH SIZE ON P550

选配件 OPTIONAL ACCESSORIES

匹配顶针 MATCHING PILOT PIN				推荐钻机 RECOMMENDED MAGNETIC DRILLING MACHINE		
钻头直径 DIAMETER	型号 MODEL	规格 SPECIFICATION	顶针 PILOT PIN	钻头直径 DIAMETER	钻机型号 MAGNETIC DRILLING MACHING	匹配夹具 MATCHING TOOL HOLDER
18-60	DPB-81160	7.98*160		18-60	DX-120	DJXY-100X-MT4



DNHC HSS ANNULAR CUTTER WITH C-TYPE UNIVERSAL SHANK 高速钢C型通用柄钢板钻

- 通用柄型, 适合各种钻机接口;
- 超硬高速钢, 分层及低摩擦力切削几何;
- 适合多种磁座钻机、钻床等设备上钻孔与环形槽加工;
- 可选TiAlN, TiN, AlCrN三种涂层, 提升性能;
- Universal shank, suitable for various magnetic drilling machine;
- HSS-E with layered and low friction cutting geometry;
- Applicable to hole drilling and process of annular flute on various magnetic drills and press;
- Choose TiAlN, TiN and AlCrN coatings to improve performance.

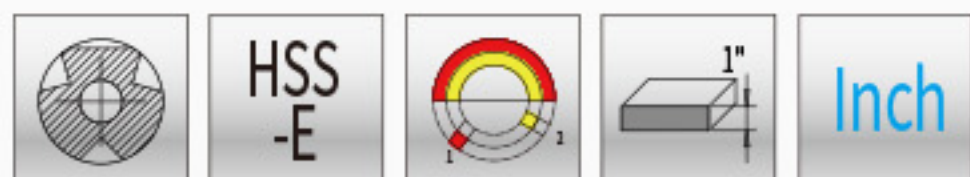
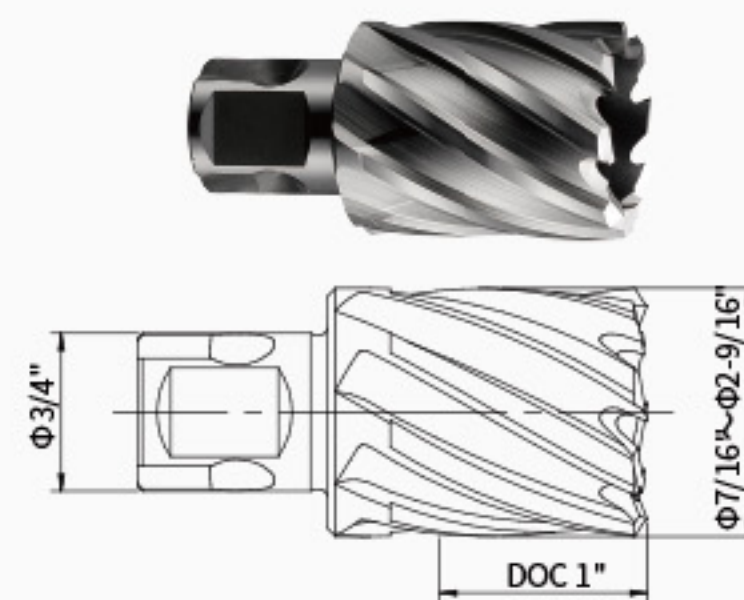

单位(Unit): inch

型号 MODEL	规格 SPECIFICATION	型号 MODEL	规格 SPECIFICATION	型号 MODEL	规格 SPECIFICATION
DNHC-B0437	7/16**1"	DNHC-B1187	1-3/16**1"	DNHC-B1937	1-15/16**1"
DNHC-B0500	1/2**1"	DNHC-B1250	1-1/4**1"	DNHC-B2000	2**1"
DNHC-B0562	9/16**1"	DNHC-B1312	1-5/16**1"	DNHC-B2062	2-1/16**1"
DNHC-B0625	5/8**1"	DNHC-B1375	1-3/8**1"	DNHC-B2125	2-1/8**1"
DNHC-B0687	11/16**1"	DNHC-B1437	1-7/16**1"	DNHC-B2187	2-3/16**1"
DNHC-B0750	3/4**1"	DNHC-B1500	1-1/2**1"	DNHC-B2250	2-1/4**1"
DNHC-B0812	13/16**1"	DNHC-B1562	1-9/16**1"	DNHC-B2312	2-5/16**1"
DNHC-B0875	7/8**1"	DNHC-B1625	1-5/8**1"	DNHC-B2375	2-3/8**1"
DNHC-B0937	15/16**1"	DNHC-B1687	1-11/16**1"	DNHC-B2437	2-7/16**1"
DNHC-B1000	1**1"	DNHC-B1750	1-3/4**1"	DNHC-B2500	2-1/2**1"
DNHC-B1062	1-1/16**1"	DNHC-B1812	1-13/16**1"	DNHC-B2562	2-9/16**1"
DNHC-B1125	1-1/8**1"	DNHC-B1875	1-7/8**1"		

公制规格详见P521 METRIC SIZE ON P521

选配件 OPTIONAL ACCESSORIES

匹配顶针 MATCHING PILOT PIN				推荐钻机 RECOMMENDED MAGNETIC DRILLING MACHINE		
钻头直径 DIAMETER	型号 MODEL	规格 SPECIFICATION	顶针 PILOT PIN	钻头直径 DIAMETER	钻机型号 MAGNETIC DRILLING MACHING	匹配夹具 MATCHING TOOL HOLDER
7/16"	DPB-42077	4.74*77		7/16"	DX-35	—
1/2"-2-9/16"	DPB-62077	6.34*77			DX-35	—
					DX-60	DJXY-50D-MT3
					DX-120	DJXY-50X-MT4

DNHC HSS ANNULAR CUTTER WITH C-TYPE UNIVERSAL SHANK 高速钢C型通用柄钢板钻

- 通用柄型, 适合各种钻机接口;
- 超硬高速钢, 分层及低摩擦力切削几何;
- 适合多种磁座钻机、钻床等设备上钻孔与环形槽加工;
- 可选TiAlN, TiN, AlCrN三种涂层, 提升性能;
- Universal shank, suitable for various magnetic drilling machine;
- HSS-E with layered and low friction cutting geometry;
- Applicable to hole drilling and process of annular flute on various magnetic drills and press;
- Choose TiAlN, TiN and AlCrN coatings to improve performance.

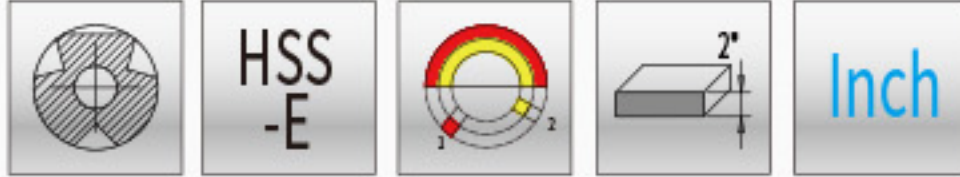
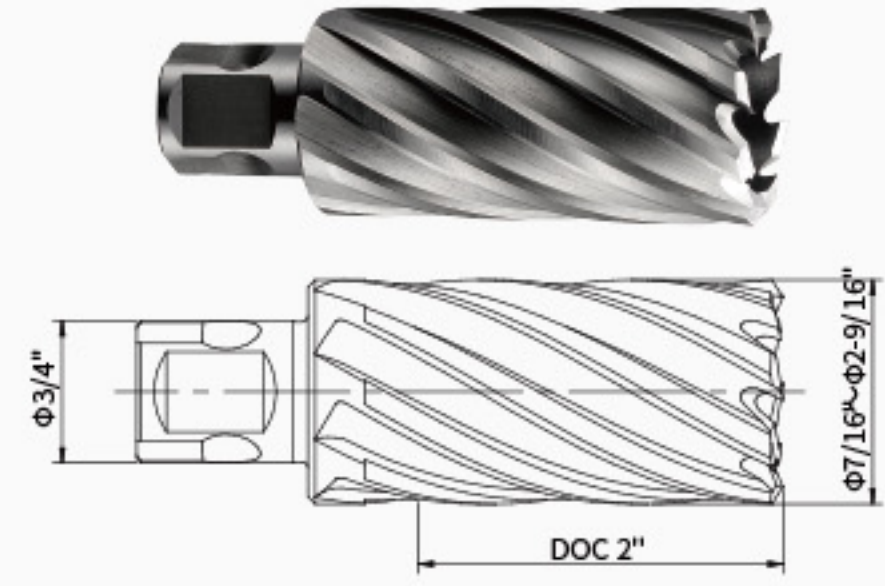

单位(Unit): inch

型号 MODEL	规格 SPECIFICATION	型号 MODEL	规格 SPECIFICATION	型号 MODEL	规格 SPECIFICATION
DNHC-D0437	7/16**2"	DNHC-D1187	1-3/16**2"	DNHC-D1937	1-15/16**2"
DNHC-D0500	1/2**2"	DNHC-D1250	1-1/4**2"	DNHC-D2000	2**2"
DNHC-D0562	9/16**2"	DNHC-D1312	1-5/16**2"	DNHC-D2062	2-1/16**2"
DNHC-D0625	5/8**2"	DNHC-D1375	1-3/8**2"	DNHC-D2125	2-1/8**2"
DNHC-D0687	11/16**2"	DNHC-D1437	1-7/16**2"	DNHC-D2187	2-3/16**2"
DNHC-D0750	3/4**2"	DNHC-D1500	1-1/2**2"	DNHC-D2250	2-1/4**2"
DNHC-D0812	13/16**2"	DNHC-D1562	1-9/16**2"	DNHC-D2312	2-5/16**2"
DNHC-D0875	7/8**2"	DNHC-D1625	1-5/8**2"	DNHC-D2375	2-3/8**2"
DNHC-D0937	15/16**2"	DNHC-D1687	1-11/16**2"	DNHC-D2437	2-7/16**2"
DNHC-D1000	1**2"	DNHC-D1750	1-3/4**2"	DNHC-D2500	2-1/2**2"
DNHC-D1062	1-1/16**2"	DNHC-D1812	1-13/16**2"	DNHC-D2562	2-9/16**2"
DNHC-D1125	1-1/8**2"	DNHC-D1875	1-7/8**2"		

公制规格详见P522 METRIC SIZE ON P522

选配件 OPTIONAL ACCESSORIES

匹配顶针 MATCHING PILOT PIN				推荐钻机 RECOMMENDED MAGNETIC DRILLING MACHINE		
钻头直径 DIAMETER	型号 MODEL	规格 SPECIFICATION	顶针 PILOT PIN	钻头直径 DIAMETER	钻机型号 MAGNETIC DRILLING MACHING	匹配夹具 MATCHING TOOL HOLDER
7/16"	DPB-42102	4.74*102		7/16"	DX-35	—
1/2"-2-9/16"	DPB-62102	6.34*102		1/2"	DX-35	—
				1-1/2"	DX-60	DJXY-50D-MT3
				2-9/16"	DX-120	DJXY-50X-MT4



DNHC HSS ANNULAR CUTTER WITH C-TYPE UNIVERSAL SHANK 高速钢C型通用柄钢板钻

- 通用柄型, 适合各种钻机接口;
- 超硬高速钢, 分层及低摩擦力切削几何;
- 适合多种磁座钻机、钻床等设备上钻孔与环形槽加工;
- 可选TiAlN, TiN, AlCrN三种涂层, 提升性能;
- Universal shank, suitable for various magnetic drilling machine;
- HSS-E with layered and low friction cutting geometry;
- Applicable to hole drilling and process of annular flute on various magnetic drills and press;
- Choose TiAlN, TiN and AlCrN coatings to improve performance.

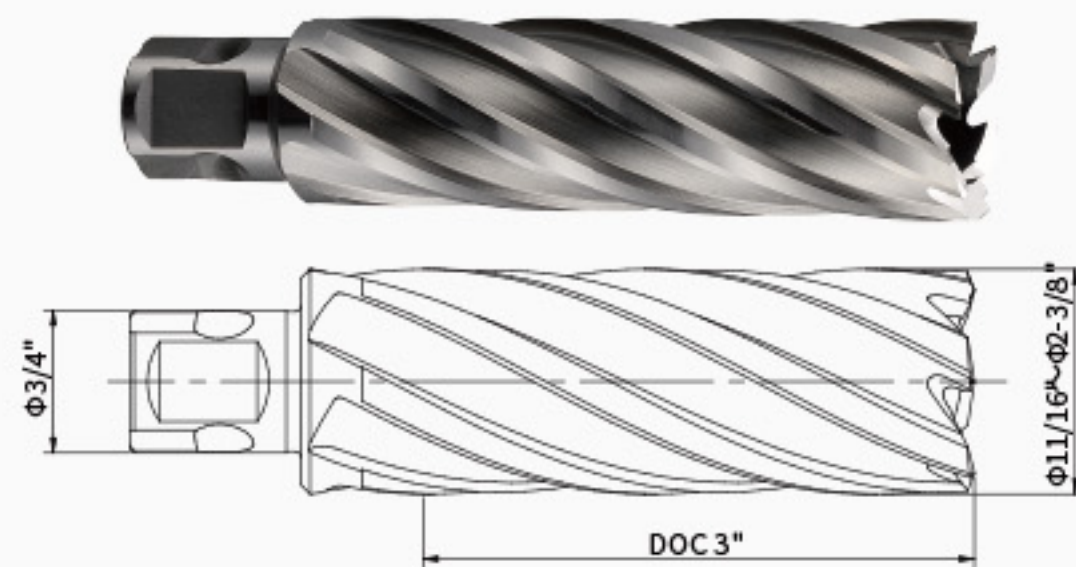

单位(Unit): inch

型号 MODEL	规格 SPECIFICATION	型号 MODEL	规格 SPECIFICATION	型号 MODEL	规格 SPECIFICATION	型号 MODEL	规格 SPECIFICATION
DNHC-E0687	11/16**3"	DNHC-E1125	1-1/8**3"	DNHC-E1562	1-9/16**3"	DNHC-E2000	2**3"
DNHC-E0750	3/4**3"	DNHC-E1187	1-3/16**3"	DNHC-E1625	1-5/8**3"	DNHC-E2062	2-1/16**3"
DNHC-E0812	13/16**3"	DNHC-E1250	1-1/4**3"	DNHC-E1687	1-11/16**3"	DNHC-E2125	2-1/8**3"
DNHC-E0875	7/8**3"	DNHC-E1312	1-5/16**3"	DNHC-E1750	1-3/4**3"	DNHC-E2187	2-3/16**3"
DNHC-E0937	15/16**3"	DNHC-E1375	1-3/8**3"	DNHC-E1812	1-13/16**3"	DNHC-E2250	2-1/4**3"
DNHC-E1000	1**3"	DNHC-E1437	1-7/16**3"	DNHC-E1875	1-7/8**3"	DNHC-E2312	2-5/16**3"
DNHC-E1062	1-1/16**3"	DNHC-E1500	1-1/2**3"	DNHC-E1937	1-15/16**3"	DNHC-E2375	2-3/8**3"

公制规格详见P523 METRIC SIZE ON P523

选配件 OPTIONAL ACCESSORIES

匹配顶针 MATCHING PILOT PIN				推荐钻机 RECOMMENDED MAGNETIC DRILLING MACHINE		
钻头直径 DIAMETER	型号 MODEL	规格 SPECIFICATION	顶针 PILOT PIN	钻头直径 DIAMETER	钻机型号 MAGNETIC DRILLING MACHINE	匹配夹具 MATCHING TOOL HOLDER
11/16"-2-3/8"	DPB-81130	7.98*130		11/16"-2-3/8"	DX-60	DJXY-75X-MT3
					DX-120	DJXY-75X-MT4



DNHC HSS ANNULAR CUTTER WITH C-TYPE UNIVERSAL SHANK 高速钢C型通用柄钢板钻

- 通用柄型, 适合各种钻机接口;
- 超硬高速钢, 分层及低摩擦力切削几何;
- 适合多种磁座钻机、钻床等设备上钻孔与环形槽加工;
- 可选TiAlN, TiN, AlCrN三种涂层, 提升性能;
- Universal shank, suitable for various magnetic drilling machine;
- HSS-E with layered and low friction cutting geometry;
- Applicable to hole drilling and process of annular flute on various magnetic drills and press;
- Choose TiAlN, TiN and AlCrN coatings to improve performance.

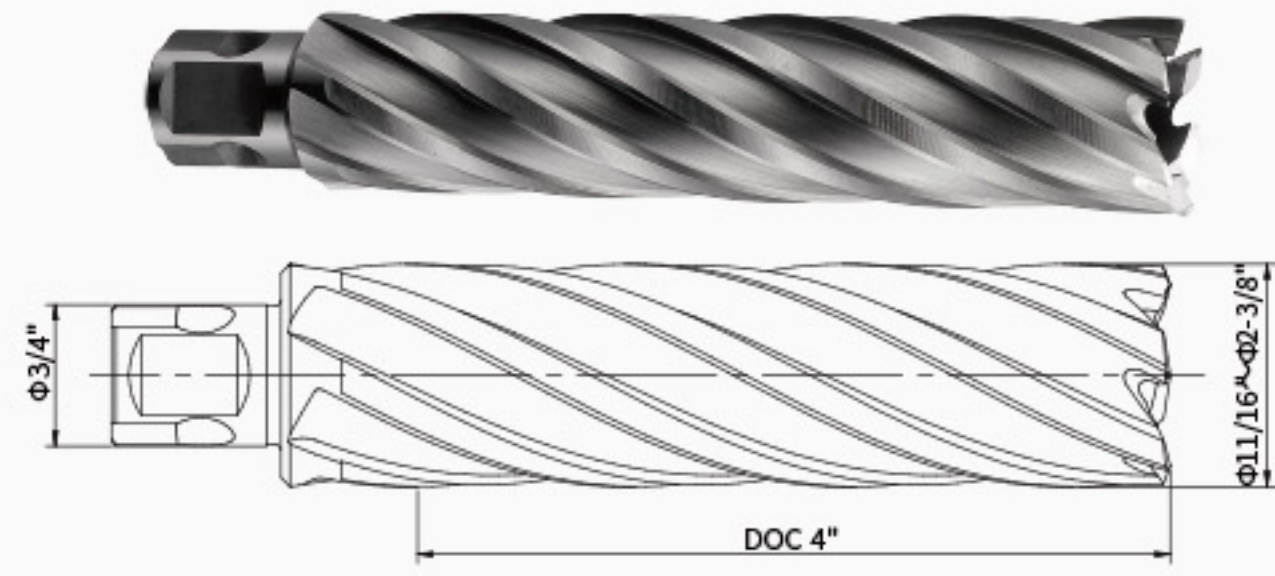

单位(Unit): inch

型号 MODEL	规格 SPECIFICATION	型号 MODEL	规格 SPECIFICATION	型号 MODEL	规格 SPECIFICATION	型号 MODEL	规格 SPECIFICATION
DNHC-F0687	11/16**4"	DNHC-F1125	1-1/8**4"	DNHC-F1562	1-9/16**4"	DNHC-F2000	2**4"
DNHC-F0750	3/4**4"	DNHC-F1187	1-3/16**4"	DNHC-F1625	1-5/8**4"	DNHC-F2062	2-1/16**4"
DNHC-F0812	13/16**4"	DNHC-F1250	1-1/4**4"	DNHC-F1687	1-11/16**4"	DNHC-F2125	2-1/8**4"
DNHC-F0875	7/8**4"	DNHC-F1312	1-5/16**4"	DNHC-F1750	1-3/4**4"	DNHC-F2187	2-3/16**4"
DNHC-F0937	15/16**4"	DNHC-F1375	1-3/8**4"	DNHC-F1812	1-13/16**4"	DNHC-F2250	2-1/4**4"
DNHC-F1000	1**4"	DNHC-F1437	1-7/16**4"	DNHC-F1875	1-7/8**4"	DNHC-F2312	2-5/16**4"
DNHC-F1062	1-1/16**4"	DNHC-F1500	1-1/2**4"	DNHC-F1937	1-15/16**4"	DNHC-F2375	2-3/8**4"

公制规格详见P520 METRIC SIZE ON P520

选配件 OPTIONAL ACCESSORIES

匹配顶针 MATCHING PILOT PIN				推荐钻机 RECOMMENDED MAGNETIC DRILLING MACHINE		
钻头直径 DIAMETER	型号 MODEL	规格 SPECIFICATION	顶针 PILOT PIN	钻头直径 DIAMETER	钻机型号 MAGNETIC DRILLING MACHING	匹配夹具 MATCHING TOOL HOLDER
11/16"-2-3/8"	DPB-81160	7.98*160		11/16"-2-3/8"	DX-120	DJXY-100X-MT4

