

# DNHK HSS ANNULAR CUTTER WITH K-TYPE WELDON SHANK 高速钢K型直角柄钢板钻

- 单孔直角柄型, 有稳固的夹持力, 更好的保证钻孔稳定性与钻孔精度, 同时也能适合单粒快速夹具夹持;
- 超硬高速钢, 分层及低摩擦力切削几何;
- 适合多种磁座钻机、钻床等设备上钻孔与环形槽加工;
- 可选TiAlN, TiN, AlCrN三种涂层, 提升性能;
- Weldon shank+1 additional hole with more stable clamping, better to ensure the stability and accuracy of drilling. Suitable for quick-change arbor with one ball;
- HSS-E with layered and low friction cutting geometry;
- Applicable to hole cutting and process of annular flute on various magnetic drills and press.
- Choose TiAlN, tin and AlCrN coatings to improve performance.

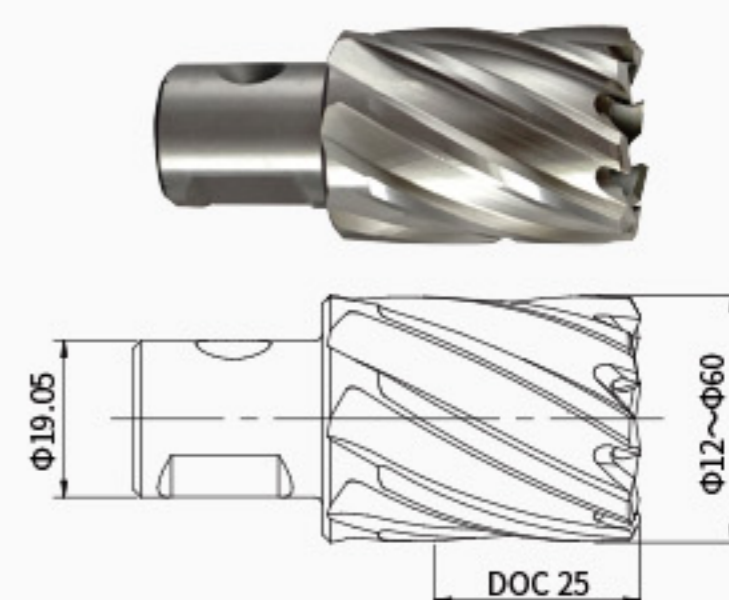

单位(Unit): mm

型号 MODEL	规格 SPECIFICATION	型号 MODEL	规格 SPECIFICATION	型号 MODEL	规格 SPECIFICATION	型号 MODEL	规格 SPECIFICATION
DNHK-20120	12*25	DNHK-20260	26*25	DNHK-20400	40*25	DNHK-20540	54*25
DNHK-20130	13*25	DNHK-20270	27*25	DNHK-20410	41*25	DNHK-20550	55*25
DNHK-20140	14*25	DNHK-20280	28*25	DNHK-20420	42*25	DNHK-20560	56*25
DNHK-20150	15*25	DNHK-20290	29*25	DNHK-20430	43*25	DNHK-20570	57*25
DNHK-20160	16*25	DNHK-20300	30*25	DNHK-20440	44*25	DNHK-20580	58*25
DNHK-20170	17*25	DNHK-20310	31*25	DNHK-20450	45*25	DNHK-20590	59*25
DNHK-20180	18*25	DNHK-20320	32*25	DNHK-20460	46*25	DNHK-20600	60*25
DNHK-20190	19*25	DNHK-20330	33*25	DNHK-20470	47*25		
DNHK-20200	20*25	DNHK-20340	34*25	DNHK-20480	48*25		
DNHK-20210	21*25	DNHK-20350	35*25	DNHK-20490	49*25		
DNHK-20220	22*25	DNHK-20360	36*25	DNHK-20500	50*25		
DNHK-20230	23*25	DNHK-20370	37*25	DNHK-20510	51*25		
DNHK-20240	24*25	DNHK-20380	38*25	DNHK-20520	52*25		
DNHK-20250	25*25	DNHK-20390	39*25	DNHK-20530	53*25		

英制规格详见P555 INCH SIZE ON P555

## 选配件 OPTIONAL ACCESSORIES

匹配顶针 MATCHING PILOT PIN				推荐钻机 RECOMMENDED MAGNETIC DRILLING MACHINE		
钻头直径 DIAMETER	型号 MODEL	规格 SPECIFICATION	顶针 PILOT PIN	钻头直径 DIAMETER	钻机型号 MAGNETIC DRILLING MACHINE	匹配夹具 MATCHING TOOL HOLDER
12-60	DPB-62077	6.34*77			DX-35	—
					DX-60	DJXY-50D-MT3
					DX-120	DJXY-50X-MT4

# DNHK HSS ANNULAR CUTTER WITH K-TYPE WELDON SHANK 高速钢K型直角柄钢板钻

- 单孔直角柄型, 有稳固的夹持力, 更好的保证钻孔稳定性与钻孔精度, 同时也能适合单粒快速夹具夹持;
- 超硬高速钢, 分层及低摩擦力切削几何;
- 适合多种磁座钻机、钻床等设备上钻孔与环形槽加工;
- 可选TiAlN, TiN, AlCrN三种涂层, 提升性能;
- Weldon shank+1 additional hole with more stable clamping, better to ensure the stability and accuracy of drilling. Suitable for quick-change arbor with one ball;
- HSS-E with layered and low friction cutting geometry;
- Applicable to hole cutting and process of annular flute on various magnetic drills and press.
- Choose TiAlN, tin and AlCrN coatings to improve performance.

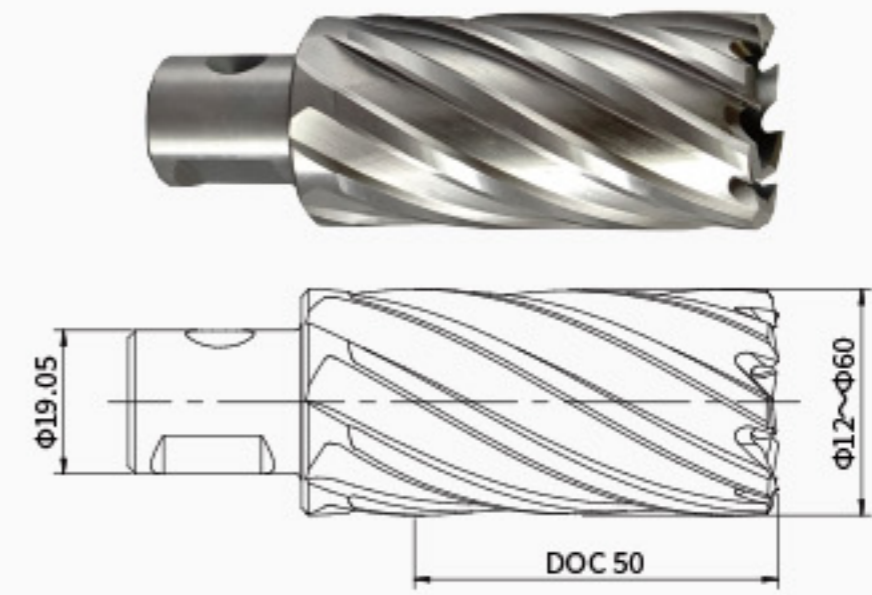

单位(Unit): mm

型号 MODEL	规格 SPECIFICATION	型号 MODEL	规格 SPECIFICATION	型号 MODEL	规格 SPECIFICATION	型号 MODEL	规格 SPECIFICATION
DNHK-40120	12*50	DNHK-40260	26*50	DNHK-40400	40*50	DNHK-40540	54*50
DNHK-40130	13*50	DNHK-40270	27*50	DNHK-40410	41*50	DNHK-40550	55*50
DNHK-40140	14*50	DNHK-40280	28*50	DNHK-40420	42*50	DNHK-40560	56*50
DNHK-40150	15*50	DNHK-40290	29*50	DNHK-40430	43*50	DNHK-40570	57*50
DNHK-40160	16*50	DNHK-40300	30*50	DNHK-40440	44*50	DNHK-40580	58*50
DNHK-40170	17*50	DNHK-40310	31*50	DNHK-40450	45*50	DNHK-40590	59*50
DNHK-40180	18*50	DNHK-40320	32*50	DNHK-40460	46*50	DNHK-40600	60*50
DNHK-40190	19*50	DNHK-40330	33*50	DNHK-40470	47*50		
DNHK-40200	20*50	DNHK-40340	34*50	DNHK-40480	48*50		
DNHK-40210	21*50	DNHK-40350	35*50	DNHK-40490	49*50		
DNHK-40220	22*50	DNHK-40360	36*50	DNHK-40500	50*50		
DNHK-40230	23*50	DNHK-40370	37*50	DNHK-40510	51*50		
DNHK-40240	24*50	DNHK-40380	38*50	DNHK-40520	52*50		
DNHK-40250	25*50	DNHK-40390	39*50	DNHK-40530	53*50		

英制规格详见P556 INCH SIZE ON P556

## 选配件 OPTIONAL ACCESSORIES

匹配顶针 MATCHING PILOT PIN				推荐钻机 RECOMMENDED MAGNETIC DRILLING MACHINE		
钻头直径 DIAMETER	型号 MODEL	规格 SPECIFICATION	顶针 PILOT PIN	钻头直径 DIAMETER	钻机型号 MAGNETIC DRILLING MACHING	匹配夹具 MATCHING TOOL HOLDER
12-60	DPB-62102	6.34*102		12-60	DX-35	—
					DX-60	DJXY-50D-MT3
					DX-120	DJXY-50X-MT4

# DNHK HSS ANNULAR CUTTER WITH K-TYPE WELDON SHANK 高速钢K型直角柄钢板钻

- 单孔直角柄型, 有稳固的夹持力, 更好的保证钻孔稳定性与钻孔精度, 同时也能适合单粒快速夹具夹持;
- 超硬高速钢, 分层及低摩擦力切削几何;
- 适合多种磁座钻机、钻床等设备上钻孔与环形槽加工;
- 可选TiAlN, TiN, AlCrN三种涂层, 提升性能;
- Weldon shank+1 additional hole with more stable clamping, better to ensure the stability and accuracy of drilling. Suitable for quick-change arbor with one ball;
- HSS-E with layered and low friction cutting geometry;
- Applicable to hole cutting and process of annular flute on various magnetic drills and press.
- Choose TiAlN, tin and AlCrN coatings to improve performance.

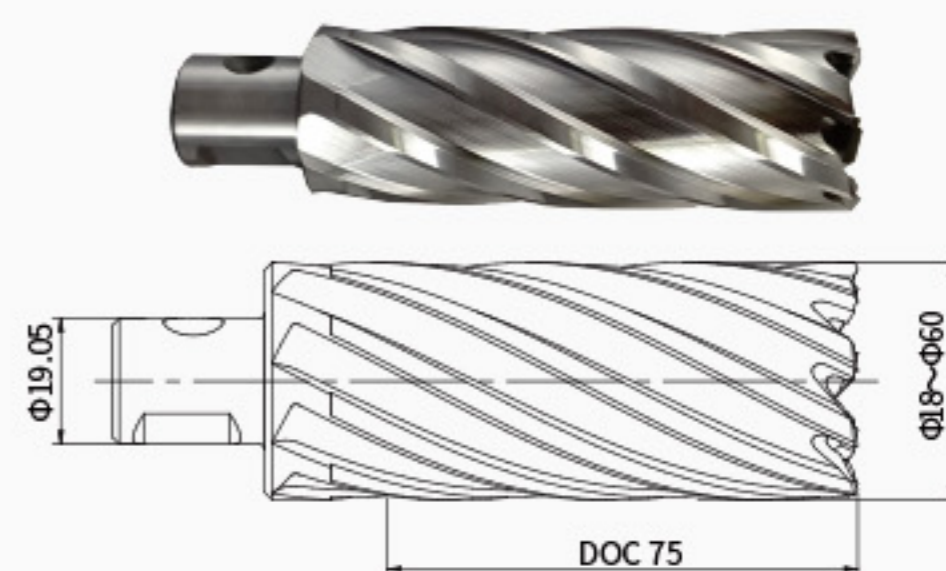

单位(Unit): mm

型号 MODEL	规格 SPECIFICATION	型号 MODEL	规格 SPECIFICATION	型号 MODEL	规格 SPECIFICATION	型号 MODEL	规格 SPECIFICATION
DNHK-50180	18*75	DNHK-50300	30*75	DNHK-50420	42*75	DNHK-50540	54*75
DNHK-50190	19*75	DNHK-50310	31*75	DNHK-50430	43*75	DNHK-50550	55*75
DNHK-50200	20*75	DNHK-50320	32*75	DNHK-50440	44*75	DNHK-50560	56*75
DNHK-50210	21*75	DNHK-50330	33*75	DNHK-50450	45*75	DNHK-50570	57*75
DNHK-50220	22*75	DNHK-50340	34*75	DNHK-50460	46*75	DNHK-50580	58*75
DNHK-50230	23*75	DNHK-50350	35*75	DNHK-50470	47*75	DNHK-50590	59*75
DNHK-50240	24*75	DNHK-50360	36*75	DNHK-50480	48*75	DNHK-50600	60*75
DNHK-50250	25*75	DNHK-50370	37*75	DNHK-50490	49*75		
DNHK-50260	26*75	DNHK-50380	38*75	DNHK-50500	50*75		
DNHK-50270	27*75	DNHK-50390	39*75	DNHK-50510	51*75		
DNHK-50280	28*75	DNHK-50400	40*75	DNHK-50520	52*75		
DNHK-50290	29*75	DNHK-50410	41*75	DNHK-50530	53*75		

英制规格详见P557 INCH SIZE ON P557

## 选配件 OPTIONAL ACCESSORIES

匹配顶针 MATCHING PILOT PIN				推荐钻机 RECOMMENDED MAGNETIC DRILLING MACHINE		
钻头直径 DIAMETER	型号 MODEL	规格 SPECIFICATION	顶针 PILOT PIN	钻头直径 DIAMETER	钻机型号 MAGNETIC DRILLING MACHING	匹配夹具 MATCHING TOOL HOLDER
18-60	DPB-81130	7.98*130		18-60	DX-60	DJXY-75X-MT3
					DX-120	DJXY-75X-MT4

# DNHK HSS ANNULAR CUTTER WITH K-TYPE WELDON SHANK 高速钢K型直角柄钢板钻

- 单孔直角柄型, 有稳固的夹持力, 更好的保证钻孔稳定性与钻孔精度, 同时也能适合单粒快速夹具夹持;
- 超硬高速钢, 分层及低摩擦力切削几何;
- 适合多种磁座钻机、钻床等设备上钻孔与环形槽加工;
- 可选TiAlN, TiN, AlCrN三种涂层, 提升性能;
- Weldon shank+1 additional hole with more stable clamping, better to ensure the stability and accuracy of drilling. Suitable for quick-change arbor with one ball;
- HSS-E with layered and low friction cutting geometry;
- Applicable to hole cutting and process of annular flute on various magnetic drills and press.
- Choose TiAlN, tin and AlCrN coatings to improve performance.

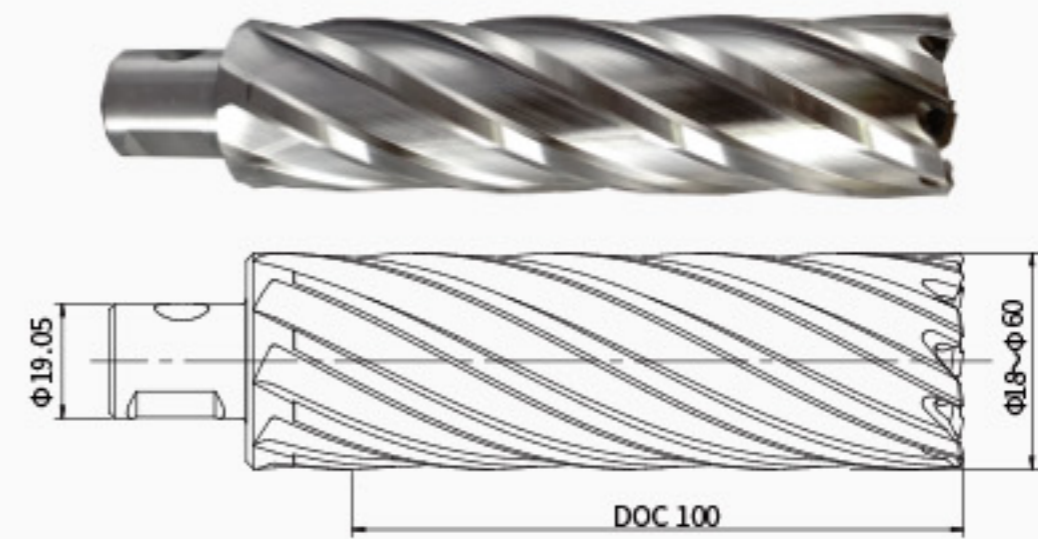

单位(Unit): mm

型号 MODEL	规格 SPECIFICATION	型号 MODEL	规格 SPECIFICATION	型号 MODEL	规格 SPECIFICATION	型号 MODEL	规格 SPECIFICATION
DNHK-60180	18*100	DNHK-60300	30*100	DNHK-60420	42*100	DNHK-60540	54*100
DNHK-60190	19*100	DNHK-60310	31*100	DNHK-60430	43*100	DNHK-60550	55*100
DNHK-60200	20*100	DNHK-60320	32*100	DNHK-60440	44*100	DNHK-60560	56*100
DNHK-60210	21*100	DNHK-60330	33*100	DNHK-60450	45*100	DNHK-60570	57*100
DNHK-60220	22*100	DNHK-60340	34*100	DNHK-60460	46*100	DNHK-60580	58*100
DNHK-60230	23*100	DNHK-60350	35*100	DNHK-60470	47*100	DNHK-60590	59*100
DNHK-60240	24*100	DNHK-60360	36*100	DNHK-60480	48*100	DNHK-60600	60*100
DNHK-60250	25*100	DNHK-60370	37*100	DNHK-60490	49*100		
DNHK-60260	26*100	DNHK-60380	38*100	DNHK-60500	50*100		
DNHK-60270	27*100	DNHK-60390	39*100	DNHK-60510	51*100		
DNHK-60280	28*100	DNHK-60400	40*100	DNHK-60520	52*100		
DNHK-60290	29*100	DNHK-60410	41*100	DNHK-60530	53*100		

英制规格详见P558 INCH SIZE ON P558

## 选配件 OPTIONAL ACCESSORIES

匹配顶针 MATCHING PILOT PIN				推荐钻机 RECOMMENDED MAGNETIC DRILLING MACHINE		
钻头直径 DIAMETER	型号 MODEL	规格 SPECIFICATION	顶针 PILOT PIN	钻头直径 DIAMETER	钻机型号 MAGNETIC DRILLING MACHING	匹配夹具 MATCHING TOOL HOLDER
18-60	DPB-81160	7.98*160		18-60	DX-120	DJXY-100X-MT4



# DNHK HSS ANNULAR CUTTER WITH K-TYPE WELDON SHANK 高速钢K型直角柄钢板钻

- 单孔直角柄型, 有稳固的夹持力, 更好的保证钻孔稳定性与钻孔精度, 同时也能适合单粒快速夹具夹持;
- 超硬高速钢, 分层及低摩擦力切削几何;
- 适合多种磁座钻机、钻床等设备上钻孔与环形槽加工;
- 可选TiAlN, TiN, AlCrN三种涂层, 提升性能;
- Weldon shank+1 additional hole with more stable clamping, better to ensure the stability and accuracy of drilling. Suitable for quick-change arbor with one ball;
- HSS-E with layered and low friction cutting geometry;
- Applicable to hole cutting and process of annular flute on various magnetic drills and press.
- Choose TiAlN, tin and AlCrN coatings to improve performance.

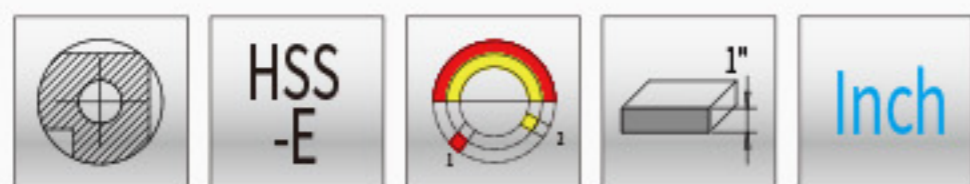
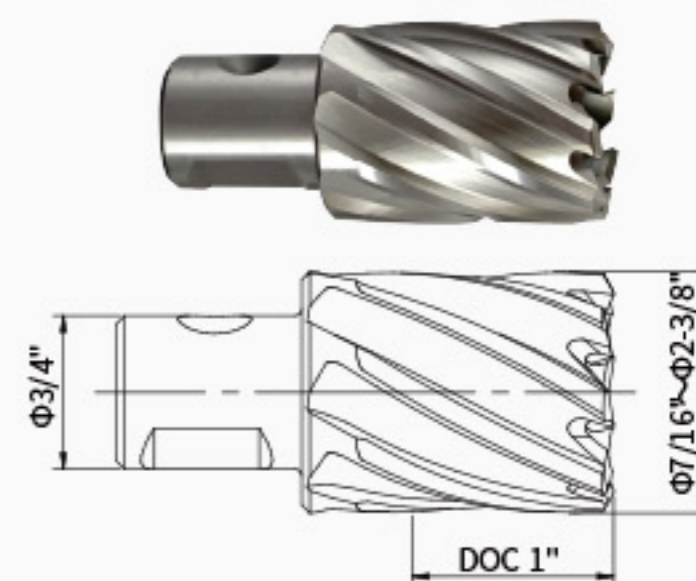

单位(Unit): inch

型号 MODEL	规格 SPECIFICATION	型号 MODEL	规格 SPECIFICATION	型号 MODEL	规格 SPECIFICATION
DNHK-B0437	7/16**1"	DNHK-B1187	1-3/16**1"	DNHK-B1937	1-15/16**1"
DNHK-B0500	1/2**1"	DNHK-B1250	1-1/4**1"	DNHK-B2000	2**1"
DNHK-B0562	9/16**1"	DNHK-B1312	1-5/16**1"	DNHK-B2062	2-1/16**1"
DNHK-B0625	5/8**1"	DNHK-B1375	1-3/8**1"	DNHK-B2125	2-1/8**1"
DNHK-B0687	11/16**1"	DNHK-B1437	1-7/16**1"	DNHK-B2187	2-3/16**1"
DNHK-B0750	3/4**1"	DNHK-B1500	1-1/2**1"	DNHK-B2250	2-1/4**1"
DNHK-B0812	13/16**1"	DNHK-B1562	1-9/16**1"	DNHK-B2312	2-5/16**1"
DNHK-B0875	7/8**1"	DNHK-B1625	1-5/8**1"	DNHK-B2375	2-3/8**1"
DNHK-B0937	15/16**1"	DNHK-B1687	1-11/16**1"		
DNHK-B1000	1**1"	DNHK-B1750	1-3/4**1"		
DNHK-B1062	1-1/16**1"	DNHK-B1812	1-13/16**1"		
DNHK-B1125	1-1/8**1"	DNHK-B1875	1-7/8**1"		

公制规格详见P533 METRIC SIZE ON P533

## 选配件 OPTIONAL ACCESSORIES

匹配顶针 MATCHING PILOT PIN				推荐钻机 RECOMMENDED MAGNETIC DRILLING MACHINE		
钻头直径 DIAMETER	型号 MODEL	规格 SPECIFICATION	顶针 PILOT PIN	钻头直径 DIAMETER	钻机型号 MAGNETIC DRILLING MACHING	匹配夹具 MATCHING TOOL HOLDER
7/16"	DPB-42077	4.74*77		7/16"	DX-35	—
1/2"-2-3/8"	DPB-62077	6.34*77		DX-35	—	
				DX-60	DJXY-50D-MT3	
				DX-120	DJXY-50X-MT4	

# DNHK HSS ANNULAR CUTTER WITH K-TYPE WELDON SHANK 高速钢K型直角柄钢板钻

- 单孔直角柄型, 有稳固的夹持力, 更好的保证钻孔稳定性与钻孔精度, 同时也能适合单粒快速夹具夹持;
- 超硬高速钢, 分层及低摩擦力切削几何;
- 适合多种磁座钻机、钻床等设备上钻孔与环形槽加工;
- 可选TiAlN, TiN, AlCrN三种涂层, 提升性能;
- Weldon shank+1 additional hole with more stable clamping, better to ensure the stability and accuracy of drilling. Suitable for quick-change arbor with one ball;
- HSS-E with layered and low friction cutting geometry;
- Applicable to hole cutting and process of annular flute on various magnetic drills and press.
- Choose TiAlN, tin and AlCrN coatings to improve performance.

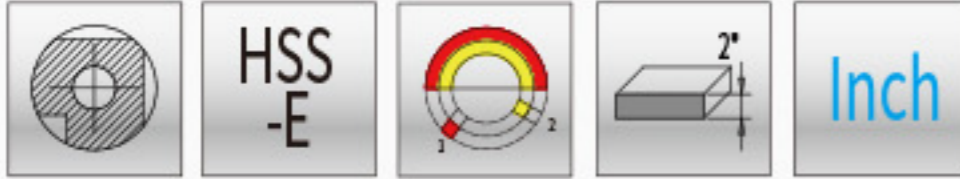
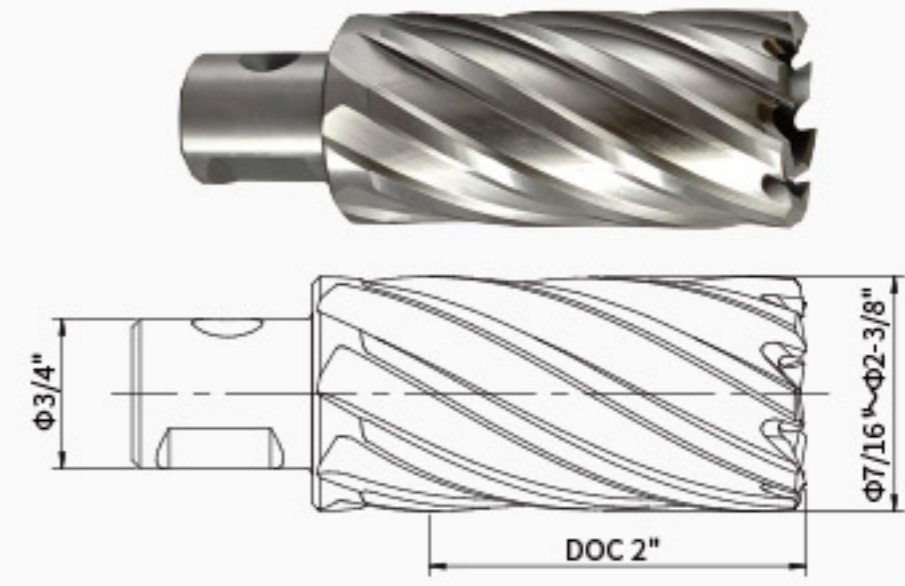

单位(Unit): inch

型号 MODEL	规格 SPECIFICATION	型号 MODEL	规格 SPECIFICATION	型号 MODEL	规格 SPECIFICATION
DNHK-D0437	7/16**2"	DNHK-D1187	1-3/16**2"	DNHK-D1937	1-15/16**2"
DNHK-D0500	1/2**2"	DNHK-D1250	1-1/4**2"	DNHK-D2000	2**2"
DNHK-D0562	9/16**2"	DNHK-D1312	1-5/16**2"	DNHK-D2062	2-1/16**2"
DNHK-D0625	5/8**2"	DNHK-D1375	1-3/8**2"	DNHK-D2125	2-1/8**2"
DNHK-D0687	11/16**2"	DNHK-D1437	1-7/16**2"	DNHK-D2187	2-3/16**2"
DNHK-D0750	3/4**2"	DNHK-D1500	1-1/2**2"	DNHK-D2250	2-1/4**2"
DNHK-D0812	13/16**2"	DNHK-D1562	1-9/16**2"	DNHK-D2312	2-5/16**2"
DNHK-D0875	7/8**2"	DNHK-D1625	1-5/8**2"	DNHK-D2375	2-3/8**2"
DNHK-D0937	15/16**2"	DNHK-D1687	1-11/16**2"		
DNHK-D1000	1**2"	DNHK-D1750	1-3/4**2"		
DNHK-D1062	1-1/16**2"	DNHK-D1812	1-13/16**2"		
DNHK-D1125	1-1/8**2"	DNHK-D1875	1-7/8**2"		

公制规格详见P534 METRIC SIZE ON P534

## 选配件 OPTIONAL ACCESSORIES

匹配顶针 MATCHING PILOT PIN				推荐钻机 RECOMMENDED MAGNETIC DRILLING MACHINE		
钻头直径 DIAMETER	型号 MODEL	规格 SPECIFICATION	顶针 PILOT PIN	钻头直径 DIAMETER	钻机型号 MAGNETIC DRILLING MACHING	匹配夹具 MATCHING TOOL HOLDER
7/16"	DPB-42102	4.74*102		7/16"	DX-35	—
1/2"~2-3/8"	DPB-62102	6.34*102			DX-35	—
					DX-60	DJXY-50D-MT3
					DX-120	DJXY-50X-MT4

# DNHK HSS ANNULAR CUTTER WITH K-TYPE WELDON SHANK 高速钢K型直角柄钢板钻

- 单孔直角柄型, 有稳固的夹持力, 更好的保证钻孔稳定性与钻孔精度, 同时也能适合单粒快速夹具夹持;
- 超硬高速钢, 分层及低摩擦力切削几何;
- 适合多种磁座钻机、钻床等设备上钻孔与环形槽加工;
- 可选TiAlN, TiN, AlCrN三种涂层, 提升性能;
- Weldon shank+1 additional hole with more stable clamping, better to ensure the stability and accuracy of drilling. Suitable for quick-change arbor with one ball;
- HSS-E with layered and low friction cutting geometry;
- Applicable to hole cutting and process of annular flute on various magnetic drills and press.
- Choose TiAlN, tin and AlCrN coatings to improve performance.

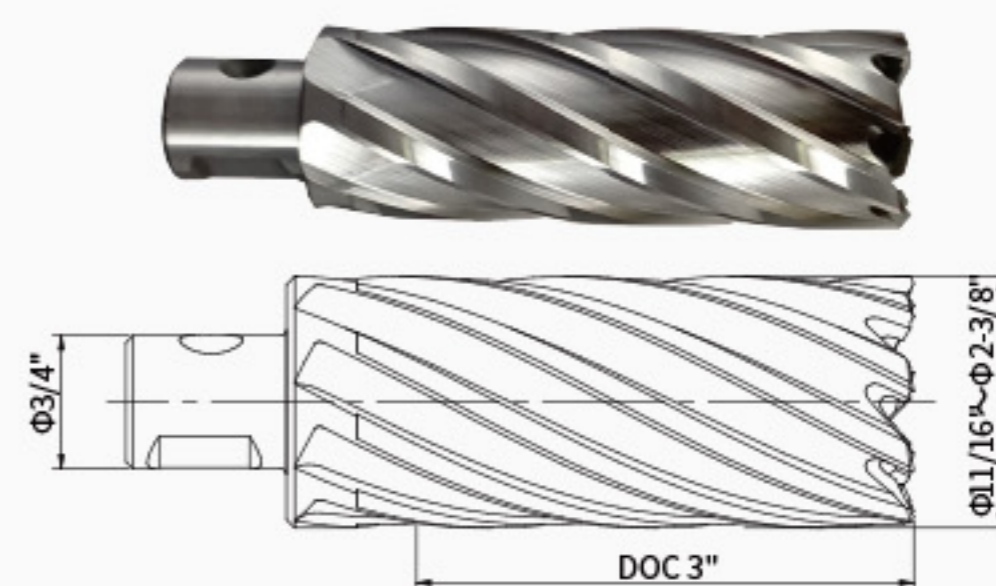

单位(Unit): inch

型号 MODEL	规格 SPECIFICATION	型号 MODEL	规格 SPECIFICATION	型号 MODEL	规格 SPECIFICATION	型号 MODEL	规格 SPECIFICATION
DNHK-E0687	11/16**3"	DNHK-E1125	1-1/8**3"	DNHK-E1562	1-9/16**3"	DNHK-E2000	2**3"
DNHK-E0750	3/4**3"	DNHK-E1187	1-3/16**3"	DNHK-E1625	1-5/8**3"	DNHK-E2062	2-1/16**3"
DNHK-E0812	13/16**3"	DNHK-E1250	1-1/4**3"	DNHK-E1687	1-11/16**3"	DNHK-E2125	2-1/8**3"
DNHK-E0875	7/8**3"	DNHK-E1312	1-5/16**3"	DNHK-E1750	1-3/4**3"	DNHK-E2187	2-3/16**3"
DNHK-E0937	15/16**3"	DNHK-E1375	1-3/8**3"	DNHK-E1812	1-13/16**3"	DNHK-E2250	2-1/4**3"
DNHK-E1000	1**3"	DNHK-E1437	1-7/16**3"	DNHK-E1875	1-7/8**3"	DNHK-E2312	2-5/16**3"
DNHK-E1062	1-1/16**3"	DNHK-E1500	1-1/2**3"	DNHK-E1937	1-15/16**3"	DNHK-E2375	2-3/8**3"

公制规格详见P535 METRIC SIZE ON P535

## 选配件 OPTIONAL ACCESSORIES

匹配顶针 MATCHING PILOT PIN				推荐钻机 RECOMMENDED MAGNETIC DRILLING MACHINE		
钻头直径 DIAMETER	型号 MODEL	规格 SPECIFICATION	顶针 PILOT PIN	钻头直径 DRILL DIAMETER	钻机型号 MAGNETIC DRILLING MACHINE	匹配夹具 MATCHING TOOL HOLDER
11/16"-2-3/8"	DPB-81130	7.98*130		11/16"-2-3/8"	DX-60 DX-120	DJXY-75X-MT3 DJXY-75X-MT4

# DNHK HSS ANNULAR CUTTER WITH K-TYPE WELDON SHANK 高速钢K型直角柄钢板钻

- 单孔直角柄型, 有稳固的夹持力, 更好的保证钻孔稳定性与钻孔精度, 同时也能适合单粒快速夹具夹持;
- 超硬高速钢, 分层及低摩擦力切削几何;
- 适合多种磁座钻机、钻床等设备上钻孔与环形槽加工;
- 可选TiAlN, TiN, AlCrN三种涂层, 提升性能;
- Weldon shank+1 additional hole with more stable clamping, better to ensure the stability and accuracy of drilling. Suitable for quick-change arbor with one ball;
- HSS-E with layered and low friction cutting geometry;
- Applicable to hole cutting and process of annular flute on various magnetic drills and press.
- Choose TiAlN, tin and AlCrN coatings to improve performance.

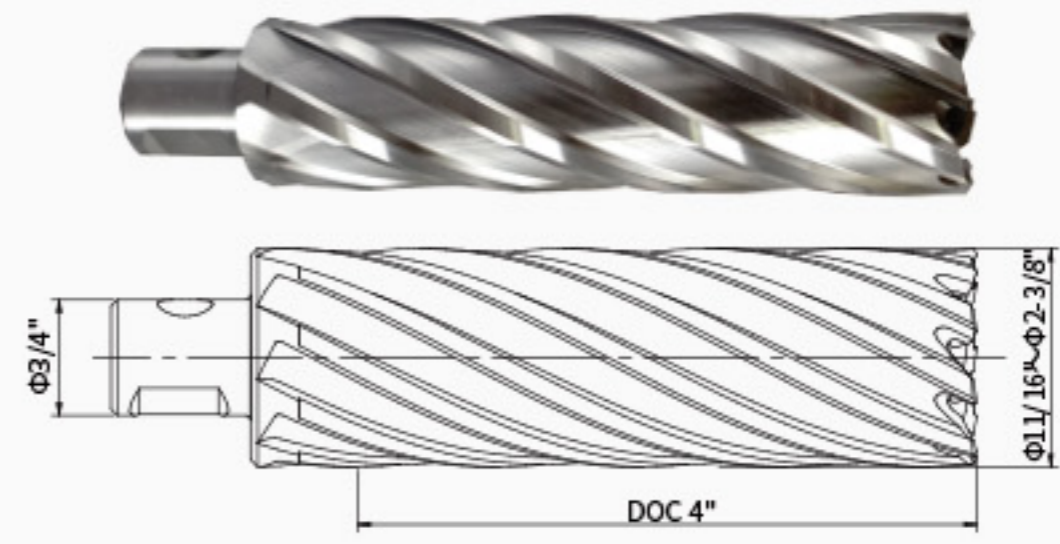

单位(Unit): inch

型号 MODEL	规格 SPECIFICATION	型号 MODEL	规格 SPECIFICATION	型号 MODEL	规格 SPECIFICATION	型号 MODEL	规格 SPECIFICATION
DNHK-F0687	11/16**4"	DNHK-F1125	1-1/8**4"	DNHK-F1562	1-9/16**4"	DNHK-F2000	2**4"
DNHK-F0750	3/4**4"	DNHK-F1187	1-3/16**4"	DNHK-F1625	1-5/8**4"	DNHK-F2062	2-1/16**4"
DNHK-F0812	13/16**4"	DNHK-F1250	1-1/4**4"	DNHK-F1687	1-11/16**4"	DNHK-F2125	2-1/8**4"
DNHK-F0875	7/8**4"	DNHK-F1312	1-5/16**4"	DNHK-F1750	1-3/4**4"	DNHK-F2187	2-3/16**4"
DNHK-F0937	15/16**4"	DNHK-F1375	1-3/8**4"	DNHK-F1812	1-13/16**4"	DNHK-F2250	2-1/4**4"
DNHK-F1000	1**4"	DNHK-F1437	1-7/16**4"	DNHK-F1875	1-7/8**4"	DNHK-F2312	2-5/16**4"
DNHK-F1062	1-1/16**4"	DNHK-F1500	1-1/2**4"	DNHK-F1937	1-15/16**4"	DNHK-F2375	2-3/8**4"

公制规格详见P536 METRIC SIZE ON P536

## 选配件 OPTIONAL ACCESSORIES

匹配顶针 MATCHING PILOT PIN				推荐钻机 RECOMMENDED MAGNETIC DRILLING MACHINE		
钻头直径 DIAMETER	型号 MODEL	规格 SPECIFICATION	顶针 PILOT PIN	钻头直径 DIAMETER	钻机型号 MAGNETIC DRILLING MACHING	匹配夹具 MATCHING TOOL HOLDER
11/16"-2-3/8"	DPB-81160	7.98*160		11/16"-2-3/8"	DX-120	DJXY-100X-MT4

