

DNHL HSS ANNULAR CUTTER WITH L-TYPE THREAD SHANK 高速钢L型螺纹柄钢板钻

- 螺纹柄型, 适合专用钻机接口;
- 超硬高速钢, 分层及低摩擦力切削几何;
- 可选TiAlN, TiN, AlCrN三种涂层, 提升性能;
- Thread shank. Suitable for connector of special purpose magnetic drilling machines.;
- HSS-E with layered and low friction cutting geometry;
- Choose TiAlN, TiN and AlCrN coatings to improve performance.

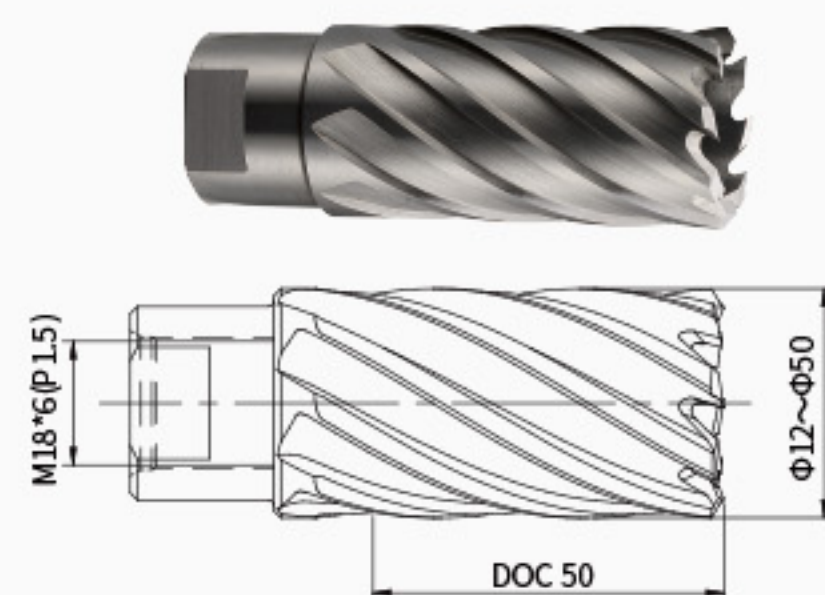

单位(Unit): mm

型号 MODEL	规格 SPECIFICATION	型号 MODEL	规格 SPECIFICATION	型号 MODEL	规格 SPECIFICATION	型号 MODEL	规格 SPECIFICATION
DNHL-40120	12*50	DNHL-40220	22*50	DNHL-40320	32*50	DNHL-40420	42*50
DNHL-40130	13*50	DNHL-40230	23*50	DNHL-40330	33*50	DNHL-40430	43*50
DNHL-40140	14*50	DNHL-40240	24*50	DNHL-40340	34*50	DNHL-40440	44*50
DNHL-40150	15*50	DNHL-40250	25*50	DNHL-40350	35*50	DNHL-40450	45*50
DNHL-40160	16*50	DNHL-40260	26*50	DNHL-40360	36*50	DNHL-40460	46*50
DNHL-40170	17*50	DNHL-40270	27*50	DNHL-40370	37*50	DNHL-40470	47*50
DNHL-40180	18*50	DNHL-40280	28*50	DNHL-40380	38*50	DNHL-40480	48*50
DNHL-40190	19*50	DNHL-40290	29*50	DNHL-40390	39*50	DNHL-40490	49*50
DNHL-40200	20*50	DNHL-40300	30*50	DNHL-40400	40*50	DNHL-40500	50*50
DNHL-40210	21*50	DNHL-40310	31*50	DNHL-40410	41*50		

选配件 OPTIONAL ACCESSORIES

匹配夹具 MATCHING TOOL HOLDER			
钻头直径 DIAMETER	型号 MODEL	规格 SPECIFICATION	夹具 TOOL HOLDER
12-50	DJLY-50K-MT2	MT2*50*M18 x6(P1.5)	