

# DNHP HSS ANNULAR CUTTER WITH P-TYPE WELDON SHANK 高速钢P型直角柄钢板钻

- 直角柄型, 保证大规格钻孔时的夹持力与夹持精度, 适合直径61mm与以上规格;
- 超硬高速钢, 分层及低摩擦力切削几何;
- 适合多种磁座钻机、钻床等设备上钻孔与环形槽加工;
- 可选TiAlN, TiN, AlCrN三种涂层, 提升性能;
- Weldon shank ensures the clamping force and clamping accuracy when drilling large diameter, and it is suitable for the diameter of 61mm and above;
- HSS-E with layered and low friction cutting geometry;
- Applicable to hole cutting and process of annular flute on various magnetic drills and press.
- Choose TiAlN, TiN and AlCrN coatings to improve performance.

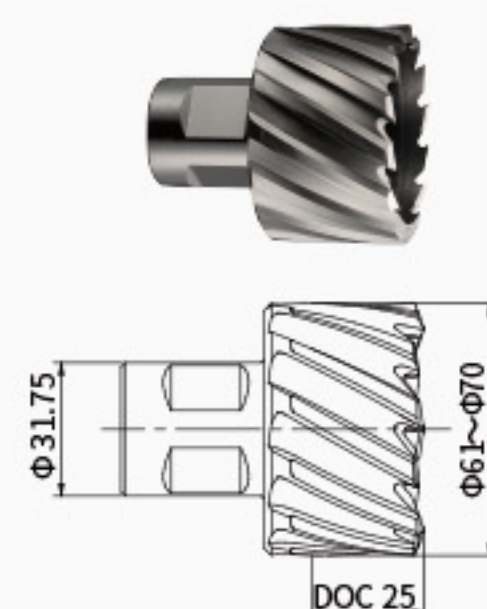

单位(Unit): mm

型号 MODEL	规格 SPECIFICATION	型号 MODEL	规格 SPECIFICATION
DNHP-20610	61*25	DNHP-20660	66*25
DNHP-20620	62*25	DNHP-20670	67*25
DNHP-20630	63*25	DNHP-20680	68*25
DNHP-20640	64*25	DNHP-20690	69*25
DNHP-20650	65*25	DNHP-20700	70*25

## 选配件 OPTIONAL ACCESSORIES

匹配顶针 MATCHING PILOT PIN				推荐钻机 RECOMMENDED MAGNETIC DRILLING MACHINE		
钻头直径 DIAMETER	型号 MODEL	规格 SPECIFICATION	顶针 PILOT PIN	钻头直径 DIAMETER	钻机型号 MAGNETIC DRILLING MACHINE	匹配夹具 MATCHING TOOL HOLDER
61-70	DPB-81090	7.98*90		61-70	DX-120	DJPY-50X-MT4

# DNHP HSS ANNULAR CUTTER WITH P-TYPE WELDON SHANK 高速钢P型直角柄钢板钻

- 直角柄型, 保证大规格钻孔时的夹持力与夹持精度, 适合直径61mm与以上规格;
- 超硬高速钢, 分层及低摩擦力切削几何;
- 适合多种磁座钻机、钻床等设备上钻孔与环形槽加工;
- 可选TiAlN, TiN, AlCrN三种涂层, 提升性能;
- Weldon shank ensures the clamping force and clamping accuracy when drilling large diameter, and it is suitable for the diameter of 61mm and above;
- HSS-E with layered and low friction cutting geometry;
- Applicable to hole cutting and process of annular flute on various magnetic drills and press.
- Choose TiAlN, TiN and AlCrN coatings to improve performance.

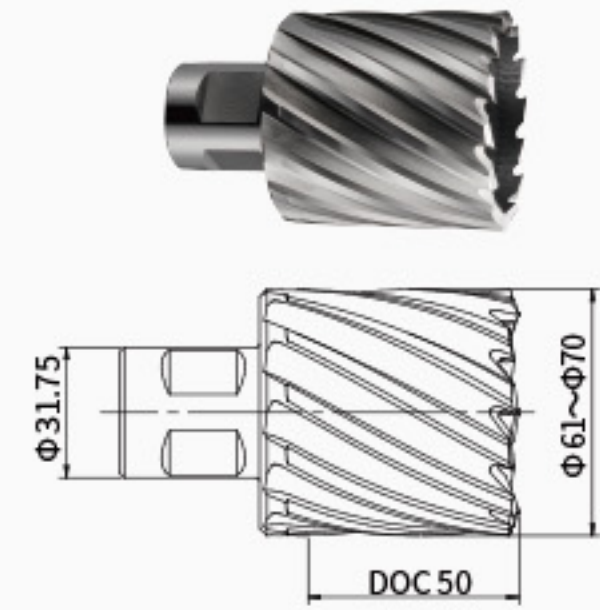

单位(Unit): mm

型号 MODEL	规格 SPECIFICATION	型号 MODEL	规格 SPECIFICATION
DNHP-40610	61*50	DNHP-40660	66*50
DNHP-40620	62*50	DNHP-40670	67*50
DNHP-40630	63*50	DNHP-40680	68*50
DNHP-40640	64*50	DNHP-40690	69*50
DNHP-40650	65*50	DNHP-40700	70*50

## 选配件 OPTIONAL ACCESSORIES

匹配顶针 MATCHING PILOT PIN				推荐钻机 RECOMMENDED MAGNETIC DRILLING MACHINE		
钻头直径 DIAMETER	型号 MODEL	规格 SPECIFICATION	顶针 PILOT PIN	钻头直径 DIAMETER	钻机型号 MAGNETIC DRILLING MACHINE	匹配夹具 MATCHING TOOL HOLDER
61-70	DPB-81113	7.98*113		61-70	DX-120	DJPY-50X-MT4

