

DNHR HSS ANNULAR CUTTER WITH R-TYPE ROUND SHANK 高速钢R型圆销柄钢板钻

- 圆销柄型, 适合专用钻机接口;
- 超硬高速钢, 分层及低摩擦力切削几何;
- 可选TiAlN, TiN, AlCrN三种涂层, 提升性能;
- 免工具快速装夹;
- Round shank. Suitable for connector of special purpose magnetic drilling machines.;
- HSS-E with layered and low friction cutting geometry;
- Choose TiAlN, TiN and AlCrN coatings to improve performance.
- Tool-free quick clamping.

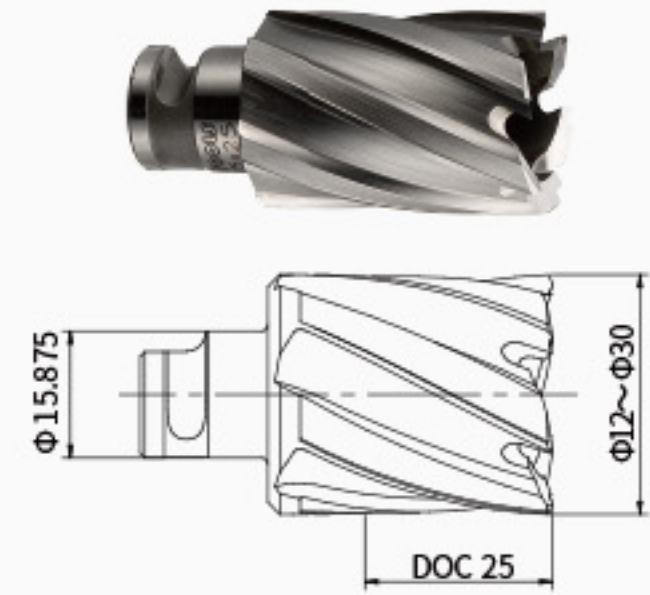

单位(Unit): mm

型号 MODEL	规格 SPECIFICATION	型号 MODEL	规格 SPECIFICATION	型号 MODEL	规格 SPECIFICATION
DNHR-20120	12*25	DNHR-20190	19*25	DNHR-20260	26*25
DNHR-20130	13*25	DNHR-20200	20*25	DNHR-20270	27*25
DNHR-20140	14*25	DNHR-20210	21*25	DNHR-20280	28*25
DNHR-20150	15*25	DNHR-20220	22*25	DNHR-20290	29*25
DNHR-20160	16*25	DNHR-20230	23*25	DNHR-20300	30*25
DNHR-20170	17*25	DNHR-20240	24*25		
DNHR-20180	18*25	DNHR-20250	25*25		

选配件 OPTIONAL ACCESSORIES

匹配顶针 MATCHING PILOT PIN			
钻头直径 DIAMETER	型号 MODEL	规格 SPECIFICATION	顶针 PILOT PIN
12-30	DPB-41062	4.74*62	

