

DRSX DRSX CARBIDE TIPPED S-TYPE RAIL CUTTER 硬质合金钢轨钻 S型

- $\Phi 19.0$ mm柄径;
- 高红硬性硬质合金刀片;
- 低温高强度焊接工艺;
- 专用切削几何;
- 水剂冷却、油雾冷却应用;
- The diameter of shank $\Phi 19.0$ mm;
- Special carbide tips with special heat treatment;
- Low temperature and high strength welding process;
- Specialized cutting geometry;
- Water cooling and Oil mist cooling are available.

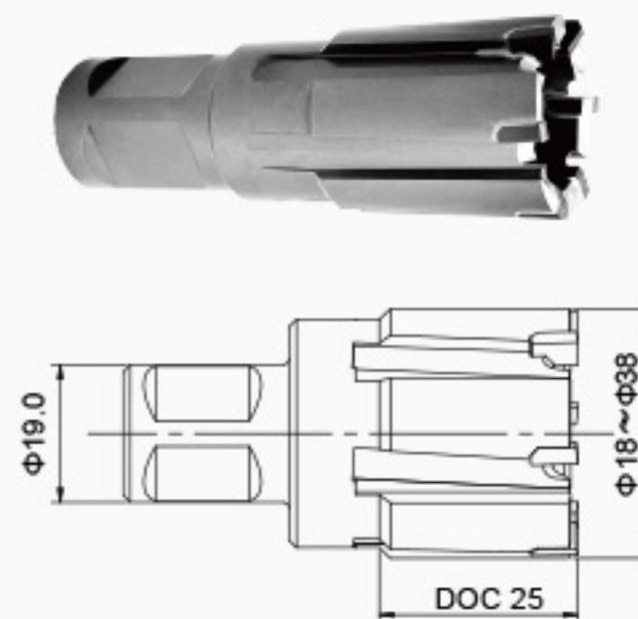

单位(Unit): mm

型号 MODEL	规格 SPECIFICATION	型号 MODEL	规格 SPECIFICATION	型号 MODEL	规格 SPECIFICATION
DRSX-20180SL	18*25	DRSX-20250SL	25*25	DRSX-20320SL	32*25
DRSX-20190SL	19*25	DRSX-20260SL	26*25	DRSX-20330SL	33*25
DRSX-20200SL	20*25	DRSX-20270SL	27*25	DRSX-20340SL	34*25
DRSX-20210SL	21*25	DRSX-20280SL	28*25	DRSX-20350SL	35*25
DRSX-20220SL	22*25	DRSX-20290SL	29*25	DRSX-20360SL	36*25
DRSX-20230SL	23*25	DRSX-20300SL	30*25	DRSX-20370SL	37*25
DRSX-20240SL	24*25	DRSX-20310SL	31*25	DRSX-20380SL	38*25

适配顶针 SUITABLE PILOT PIN

钻头直径 DIAMETER	匹配顶针 MATCHING PILOT PIN		顶针 PILOT PIN
	型号 MODEL	规格 SPECIFICATION	
$\Phi 18-38$	DPB-81077	7.98*77	

DRSX DRSX CARBIDE TIPPED S-TYPE RAIL CUTTER 硬质合金钢轨钻 S型

- $\Phi 19.0$ mm柄径;
- 高红硬性硬质合金刀片;
- 低温高强度焊接工艺;
- 专用切削几何;
- 水剂冷却、油雾冷却应用;
- The diameter of shank $\Phi 19.0$ mm;
- Speical carbide tips with special heat treatment;
- Low temperature and high strength welding process;
- Specialized cutting geometry;
- Water cooling and Oil mist cooling are available.

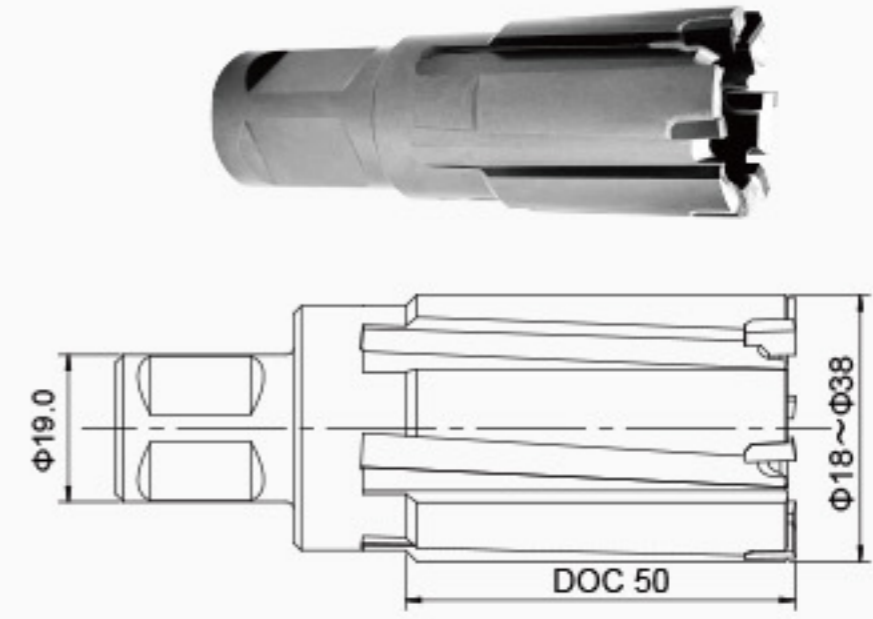

单位(Unit): mm

型号 MODEL	规格 SPECIFICATION	型号 MODEL	规格 SPECIFICATION	型号 MODEL	规格 SPECIFICATION
DRSX-40180SL	18*50	DRSX-40250SL	25*50	DRSX-40320SL	32*50
DRSX-40190SL	19*50	DRSX-40260SL	26*50	DRSX-40330SL	33*50
DRSX-40200SL	20*50	DRSX-40270SL	27*50	DRSX-40340SL	34*50
DRSX-40210SL	21*50	DRSX-40280SL	28*50	DRSX-40350SL	35*50
DRSX-40220SL	22*50	DRSX-40290SL	29*50	DRSX-40360SL	36*50
DRSX-40230SL	23*50	DRSX-40300SL	30*50	DRSX-40370SL	37*50
DRSX-40240SL	24*50	DRSX-40310SL	31*50	DRSX-40380SL	38*50

适配顶针 SUITABLE PILOT PIN

钻头直径 DIAMETER	匹配顶针 MATCHING PILOT PIN		顶针 PILOT PIN
	型号 MODEL	规格 SPECIFICATION	
$\Phi 18-38$	DPB-81103	7.98*103	

DRSX DRSX CARBIDE TIPPED S-TYPE RAIL CUTTER 硬质合金钢轨钻 S型

- $\Phi 19.05\text{mm}$ 柄径;
- 高红硬性硬质合金刀片;
- 低温高强度焊接工艺;
- 专用切削几何;
- 水剂冷却、油雾冷却应用;
- The diameter of shank $\Phi 19.05\text{mm}$;
- Special carbide tips with special heat treatment;
- Low temperature and high strength welding process;
- Specialized cutting geometry;
- Water cooling and Oil mist cooling are available.

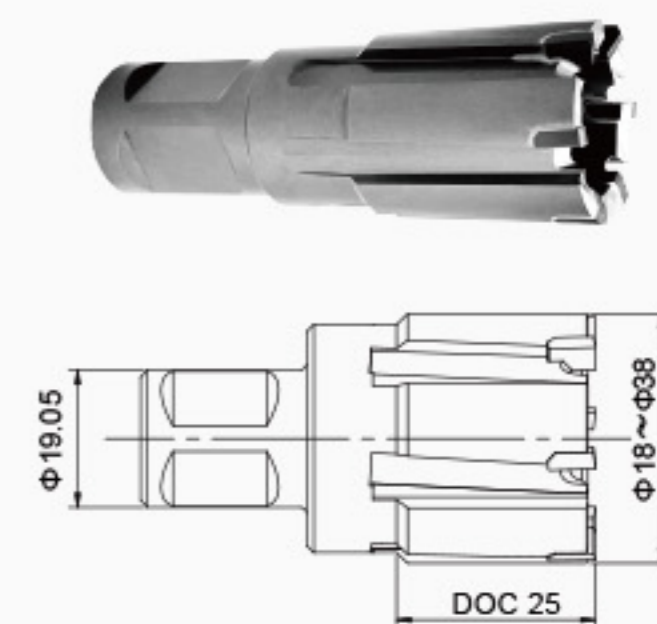

单位(Unit): mm

型号 MODEL	规格 SPECIFICATION	型号 MODEL	规格 SPECIFICATION	型号 MODEL	规格 SPECIFICATION
DRSX-20180	18*25	DRSX-20250	25*25	DRSX-20320	32*25
DRSX-20190	19*25	DRSX-20260	26*25	DRSX-20330	33*25
DRSX-20200	20*25	DRSX-20270	27*25	DRSX-20340	34*25
DRSX-20210	21*25	DRSX-20280	28*25	DRSX-20350	35*25
DRSX-20220	22*25	DRSX-20290	29*25	DRSX-20360	36*25
DRSX-20230	23*25	DRSX-20300	30*25	DRSX-20370	37*25
DRSX-20240	24*25	DRSX-20310	31*25	DRSX-20380	38*25

适配顶针 SUITABLE PILOT PIN

钻头直径 DIAMETER	匹配顶针 MATCHING PILOT PIN		顶针 PILOT PIN
	型号 MODEL	规格 SPECIFICATION	
$\Phi 18-38$	DPB-81077	7.98*77	

DRSX DRSX CARBIDE TIPPED S-TYPE RAIL CUTTER 硬质合金钢轨钻 S型

- $\Phi 19.05\text{mm}$ 柄径;
- 高红硬性硬质合金刀片;
- 低温高强度焊接工艺;
- 专用切削几何;
- 水剂冷却、油雾冷却应用;
- The diameter of shank $\Phi 19.0\text{mm}$;
- Speical carbide tips with special heat treatment;
- Low temperature and high strength welding process;
- Specialized cutting geometry;
- Water cooling and Oil mist cooling are available.

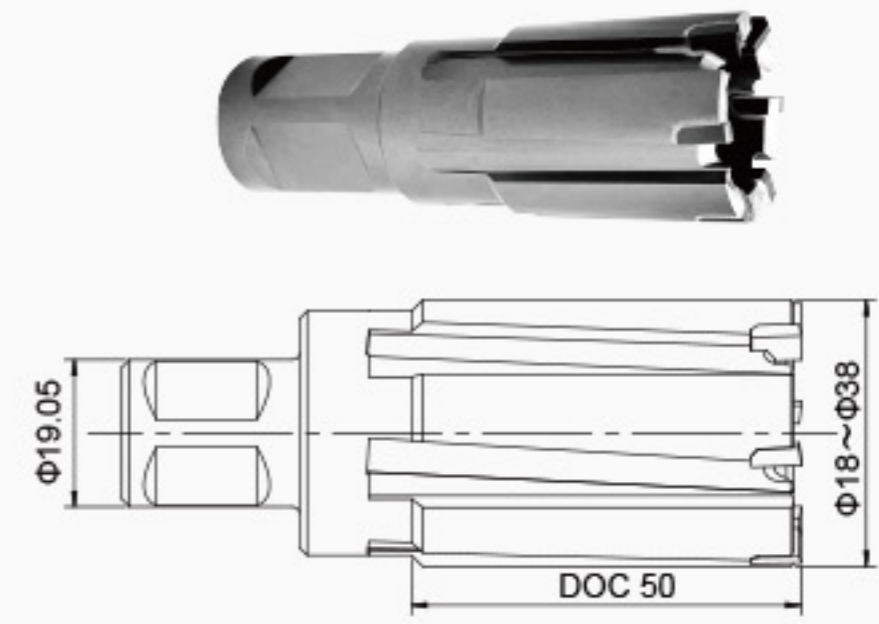

单位(Unit): mm

型号 MODEL	规格 SPECIFICATION	型号 MODEL	规格 SPECIFICATION	型号 MODEL	规格 SPECIFICATION
DRSX-40180	18*50	DRSX-40250	25*50	DRSX-40320	32*50
DRSX-40190	19*50	DRSX-40260	26*50	DRSX-40330	33*50
DRSX-40200	20*50	DRSX-40270	27*50	DRSX-40340	34*50
DRSX-40210	21*50	DRSX-40280	28*50	DRSX-40350	35*50
DRSX-40220	22*50	DRSX-40290	29*50	DRSX-40360	36*50
DRSX-40230	23*50	DRSX-40300	30*50	DRSX-40370	37*50
DRSX-40240	24*50	DRSX-40310	31*50	DRSX-40380	38*50

适配顶针 SUITABLE PILOT PIN

钻头直径 DIAMETER	匹配顶针 MATCHING PILOT PIN		顶针 PILOT PIN
	型号 MODEL	规格 SPECIFICATION	
$\Phi 18-38$	DPB-81103	7.98*103	