

# DRTT TCT RAIL CUTTER SLEEVE SHANK 硬质合金套式柄钢轨钻

- 套式专用柄, 免螺钉便捷式拆装;
- 超细颗粒硬质合金刀片; 专用切削几何;
- 低温高强度焊接工艺;
- 水剂冷却、油雾冷却应用;
- The special shank with sleeve type, Quick-In clamping without screw;
- Speical carbide tips, specialized cutting geometry;
- Low temperature and high strength welding process;
- Water cooling and Oil mist cooling are available.

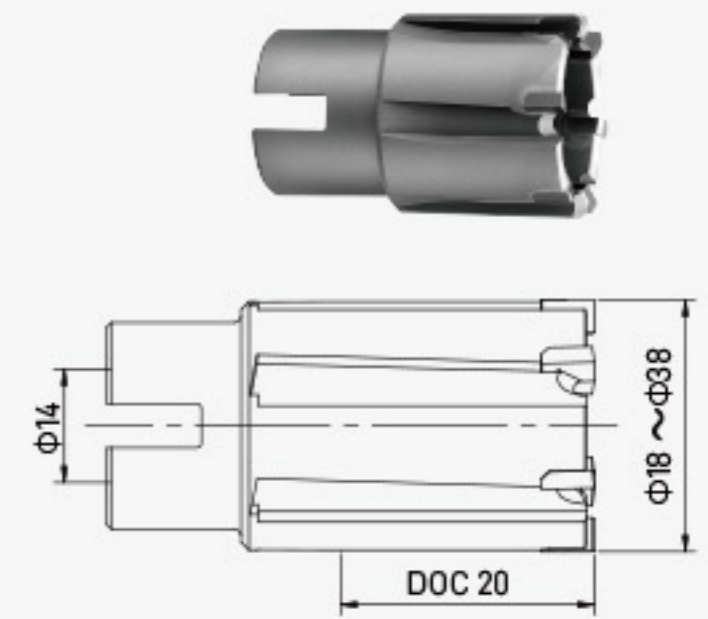

单位(Unit): mm

型号 MODEL	规格 SPECIFICATION	型号 MODEL	规格 SPECIFICATION	型号 MODEL	规格 SPECIFICATION
DRTT-10180	18*20	DRTT-10260	26*20	DRTT-10340	34*20
DRTT-10190	19*20	DRTT-10270	27*20	DRTT-10350	35*20
DRTT-10200	20*20	DRTT-10280	28*20	DRTT-10360	36*20
DRTT-10210	21*20	DRTT-10290	29*20	DRTT-10370	37*20
DRTT-10220	22*20	DRTT-10300	30*20	DRTT-10380	38*20
DRTT-10230	23*20	DRTT-10310	31*20		
DRTT-10240	24*20	DRTT-10320	32*20		
DRTT-10250	25*20	DRTT-10330	33*20		



# DRTT TCT RAIL CUTTER SLEEVE SHANK 硬质合金套式柄钢轨钻

- 套式专用柄, 免螺钉便捷式拆装;
- 超细颗粒硬质合金刀片; 专用切削几何;
- 低温高强度焊接工艺;
- 水剂冷却、油雾冷却应用;
- The special shank with shell type, Quick-in clamping without screw;
- Special carbide tips, specialized cutting geometry;
- Low temperature and high strength welding process;
- Water cooling and Oil mist cooling are available.

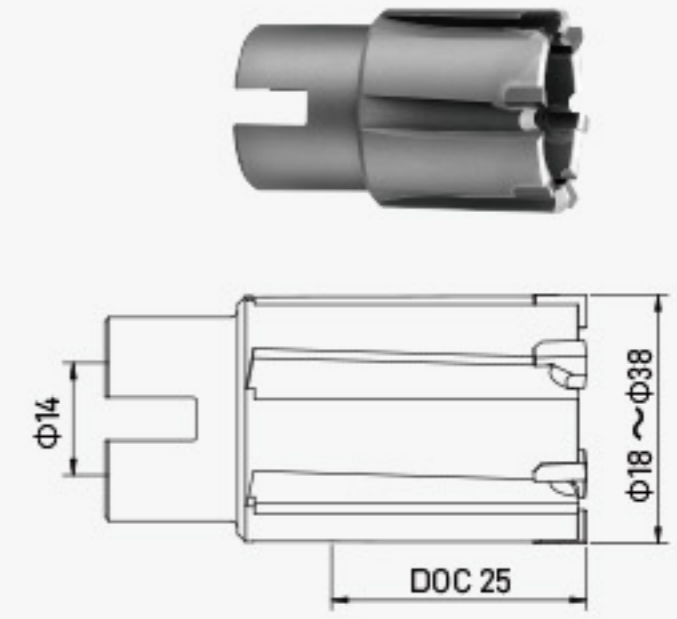

单位(Unit): mm

型号 MODEL	规格 SPECIFICATION	型号 MODEL	规格 SPECIFICATION	型号 MODEL	规格 SPECIFICATION
DRTT-20180	18*25	DRTT-20260	26*25	DRTT-20340	34*25
DRTT-20190	19*25	DRTT-20270	27*25	DRTT-20350	35*25
DRTT-20200	20*25	DRTT-20280	28*25	DRTT-20360	36*25
DRTT-20210	21*25	DRTT-20290	29*25	DRTT-20370	37*25
DRTT-20220	22*25	DRTT-20300	30*25	DRTT-20380	38*25
DRTT-20230	23*25	DRTT-20310	31*25		
DRTT-20240	24*25	DRTT-20320	32*25		
DRTT-20250	25*25	DRTT-20330	33*25		

