

DRTX CARBIDE TIPPED RAIL CUTTER 硬质合金钢轨钻

- $\Phi 19.0\text{mm}$ 柄径;
- 超细颗粒硬质合金刀片;专用切削几何;
- 低温高强度焊接工艺;
- 水剂冷却、油雾冷却应用;
- The diameter of shank $\Phi 19.0\text{mm}$;
- Speical carbide tips, speicalized cutting geometry;
- Low temperature and high strength welding process;
- Water cooling and Oil mist cooling are available.

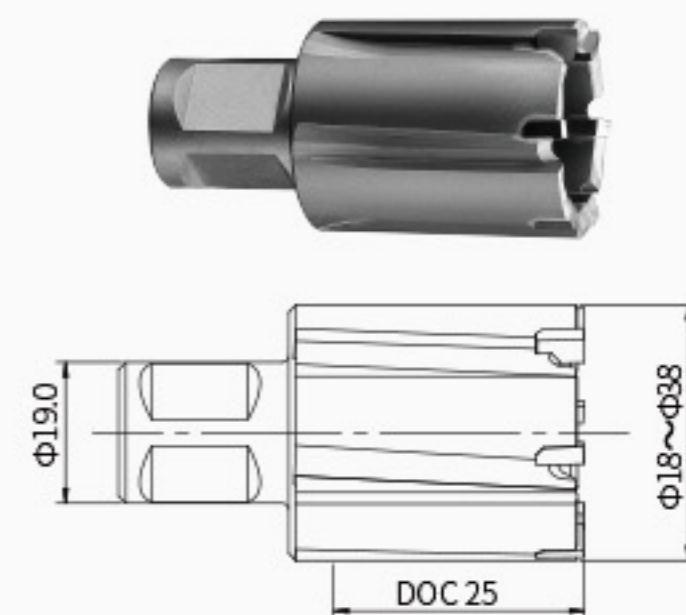

单位(Unit): mm

型号 MODEL	规格 SPECIFICATION	型号 MODEL	规格 SPECIFICATION	型号 MODEL	规格 SPECIFICATION
DRTX-20180SL	18*25	DRTX-20250SL	25*25	DRTX-20320SL	32*25
DRTX-20190SL	19*25	DRTX-20260SL	26*25	DRTX-20330SL	33*25
DRTX-20200SL	20*25	DRTX-20270SL	27*25	DRTX-20340SL	34*25
DRTX-20210SL	21*25	DRTX-20280SL	28*25	DRTX-20350SL	35*25
DRTX-20220SL	22*25	DRTX-20290SL	29*25	DRTX-20360SL	36*25
DRTX-20230SL	23*25	DRTX-20300SL	30*25	DRTX-20370SL	37*25
DRTX-20240SL	24*25	DRTX-20310SL	31*25	DRTX-20380SL	38*25

适配顶针 SUITABLE PILOT PIN

钻头直径 DIAMETER	匹配顶针 MATCHING PILOT PIN		
	型号 MODEL	规格 SPECIFICATION	顶针 PILOT PIN
$\Phi 18-38$	DPB-81077	7.98*77	

DRTX CARBIDE TIPPED RAIL CUTTER 硬质合金钢轨钻

- $\Phi 19.0\text{mm}$ 柄径;
- 超细颗粒硬质合金刀片;专用切削几何;
- 低温高强度焊接工艺;
- 水剂冷却、油雾冷却应用;
- The diameter of shank $\Phi 19.0\text{mm}$;
- Special carbide tips, specialized cutting geometry;
- Low temperature and high strength welding process;
- Water cooling and Oil mist cooling are available.

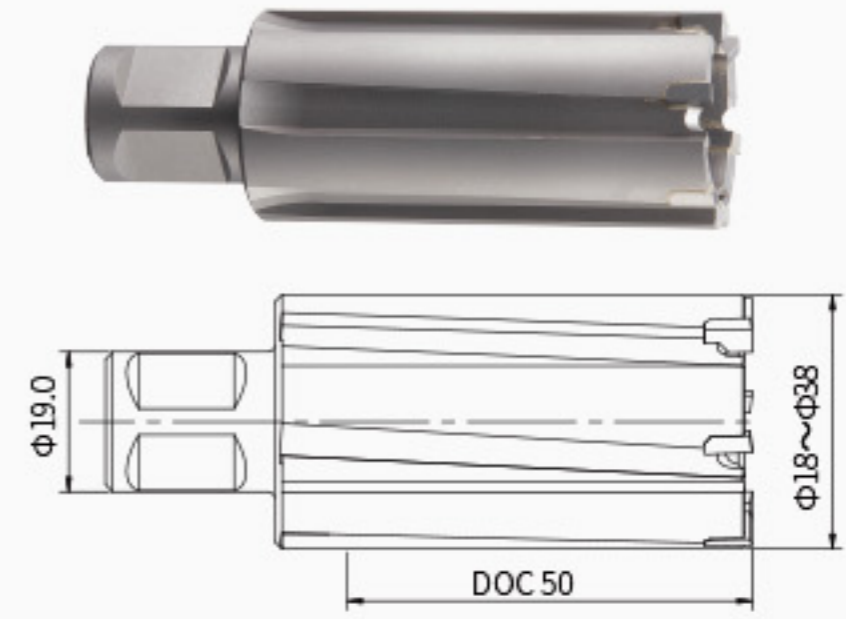

单位(Unit): mm

型号 MODEL	规格 SPECIFICATION	型号 MODEL	规格 SPECIFICATION	型号 MODEL	规格 SPECIFICATION
DRTX-40180SL	18*50	DRTX-40250SL	25*50	DRTX-40320SL	32*50
DRTX-40190SL	19*50	DRTX-40260SL	26*50	DRTX-40330SL	33*50
DRTX-40200SL	20*50	DRTX-40270SL	27*50	DRTX-40340SL	34*50
DRTX-40210SL	21*50	DRTX-40280SL	28*50	DRTX-40350SL	35*50
DRTX-40220SL	22*50	DRTX-40290SL	29*50	DRTX-40360SL	36*50
DRTX-40230SL	23*50	DRTX-40300SL	30*50	DRTX-40370SL	37*50
DRTX-40240SL	24*50	DRTX-40310SL	31*50	DRTX-40380SL	38*50

适配顶针 SUITABLE PILOT PIN

钻头直径 DIAMETER	匹配顶针 MATCHING PILOT PIN		
	型号 MODEL	规格 SPECIFICATION	顶针 PILOT PIN
$\Phi 18-38$	DPB-81103	7.98*103	



DRTX CARBIDE TIPPED RAIL CUTTER 硬质合金钢轨钻

- $\Phi 19.05\text{mm}$ 柄径;
- 超细颗粒硬质合金刀片;专用切削几何;
- 低温高强度焊接工艺;
- 水剂冷却、油雾冷却应用;
- The diameter of shank $\Phi 19.05\text{mm}$;
- Special carbide tips, specialized cutting geometry;
- Low temperature and high strength welding process;
- Water cooling and Oil mist cooling are available.

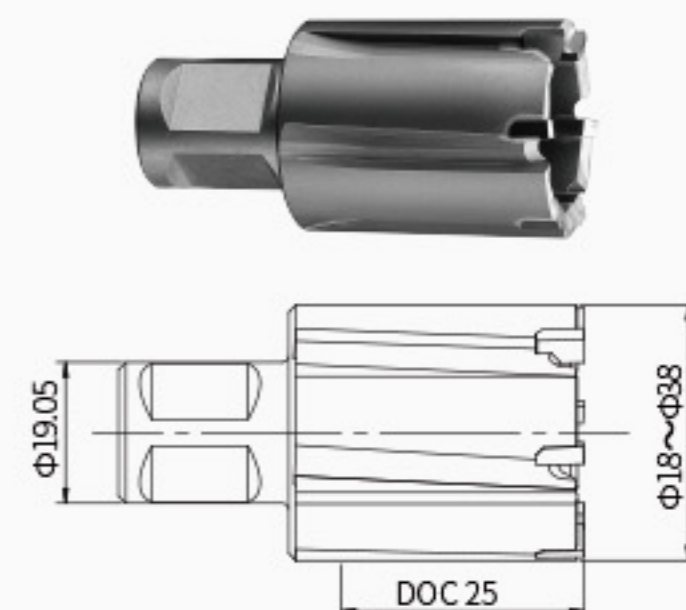

单位(Unit): mm

型号 MODEL	规格 SPECIFICATION	型号 MODEL	规格 SPECIFICATION	型号 MODEL	规格 SPECIFICATION
DRTX-20180	18*25	DRTX-20250	25*25	DRTX-20320	32*25
DRTX-20190	19*25	DRTX-20260	26*25	DRTX-20330	33*25
DRTX-20200	20*25	DRTX-20270	27*25	DRTX-20340	34*25
DRTX-20210	21*25	DRTX-20280	28*25	DRTX-20350	35*25
DRTX-20220	22*25	DRTX-20290	29*25	DRTX-20360	36*25
DRTX-20230	23*25	DRTX-20300	30*25	DRTX-20370	37*25
DRTX-20240	24*25	DRTX-20310	31*25	DRTX-20380	38*25

适配顶针 SUITABLE PILOT PIN

钻头直径 DIAMETER	匹配顶针 MATCHING PILOT PIN		顶针 PILOT PIN
	型号 MODEL	规格 SPECIFICATION	
$\Phi 18-38$	DPB-81077	7.98*77	

DRTX CARBIDE TIPPED RAIL CUTTER

硬质合金钢轨钻

- $\Phi 19.05\text{mm}$ 柄径;
- 超细颗粒硬质合金刀片;专用切削几何;
- 低温高强度焊接工艺;
- 水剂冷却、油雾冷却应用;
- The diameter of shank $\Phi 19.05\text{mm}$;
- Special carbide tips, specialized cutting geometry;
- Low temperature and high strength welding process;
- Water cooling and Oil mist cooling are available.

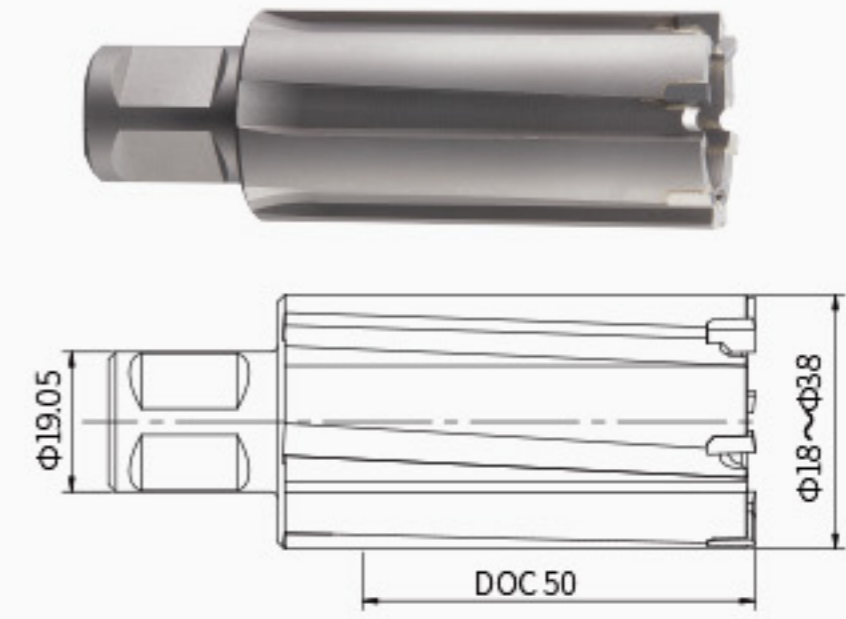

单位(Unit): mm

型号 MODEL	规格 SPECIFICATION	型号 MODEL	规格 SPECIFICATION	型号 MODEL	规格 SPECIFICATION
DRTX-40180	18*50	DRTX-40250	25*50	DRTX-40320	32*50
DRTX-40190	19*50	DRTX-40260	26*50	DRTX-40330	33*50
DRTX-40200	20*50	DRTX-40270	27*50	DRTX-40340	34*50
DRTX-40210	21*50	DRTX-40280	28*50	DRTX-40350	35*50
DRTX-40220	22*50	DRTX-40290	29*50	DRTX-40360	36*50
DRTX-40230	23*50	DRTX-40300	30*50	DRTX-40370	37*50
DRTX-40240	24*50	DRTX-40310	31*50	DRTX-40380	38*50

适配顶针 SUITABLE PILOT PIN

钻头直径 DIAMETER	匹配顶针 MATCHING PILOT PIN		顶针 PILOT PIN
	型号 MODEL	规格 SPECIFICATION	
$\Phi 18-38$	DPB-81103	7.98*103	

