

DRHX HIGH-SPEED STEEL RAIL CUTTER 高速钢钢轨钻

- $\Phi 19.0$ mm柄径;
- 超硬高速钢, 性能优越;
- 专用切削刃, 切削锋利;
- 水剂冷却、油雾冷却应用;
- The diameter of shank $\Phi 19.0$ mm;
- Super hard high speed steel, excellent performance;
- Specialized geometric cutting edge, make sure cutting sharp;
- Water cooling and Oil mist cooling are available.

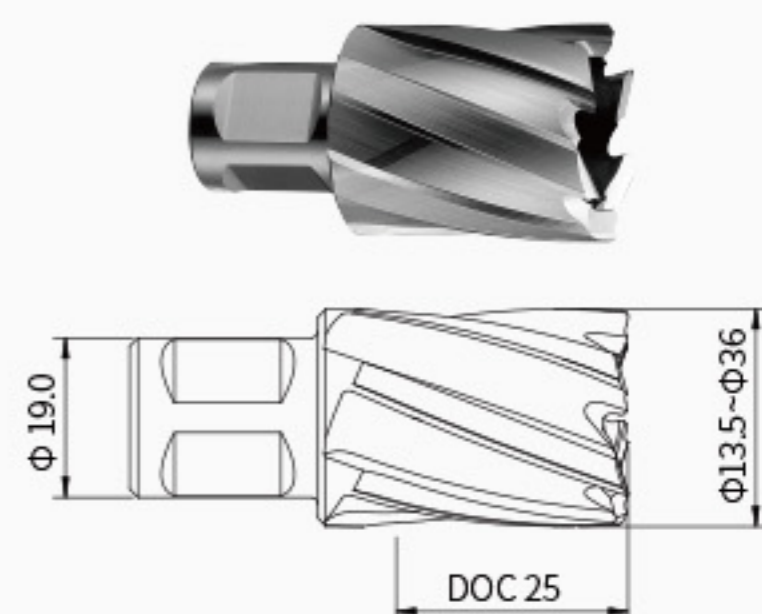

单位(Unit): mm

型号 MODEL	规格 SPECIFICATION	型号 MODEL	规格 SPECIFICATION	型号 MODEL	规格 SPECIFICATION
DRHX-20135FL	13.5*25	DRHX-20240FL	24*25	DRHX-20310FL	31*25
DRHX-20180FL	18*25	DRHX-20250FL	25*25	DRHX-20320FL	32*25
DRHX-20190FL	19*25	DRHX-20260FL	26*25	DRHX-20330FL	33*25
DRHX-20200FL	20*25	DRHX-20270FL	27*25	DRHX-20340FL	34*25
DRHX-20210FL	21*25	DRHX-20280FL	28*25	DRHX-20350FL	35*25
DRHX-20220FL	22*25	DRHX-20290FL	29*25	DRHX-20360FL	36*25
DRHX-20230FL	23*25	DRHX-20300FL	30*25		

适配顶针 SUITABLE PILOT PIN

钻头直径 DIAMETER	匹配顶针 MATCHING PILOT PIN		
	型号 MODEL	规格 SPECIFICATION	顶针 PILOT PIN
$\Phi 13.5 - 17$	DPB-62077	6.34*5.3*77	
$\Phi 18 - 36$	DPB-81077	7.98*77	

DRHX HIGH-SPEED STEEL RAIL CUTTER 高速钢钢轨钻

- $\Phi 19.0$ mm柄径;
- 超硬高速钢, 性能优越;
- 专用切削刃, 切削锋利;
- 水剂冷却、油雾冷却应用;

- The diameter of shank $\Phi 19.0$ mm;
- Super hard high speed steel, excellent performance;
- Specialized geometric cutting edge, make sure cutting sharp;
- Water cooling and Oil mist cooling are available.

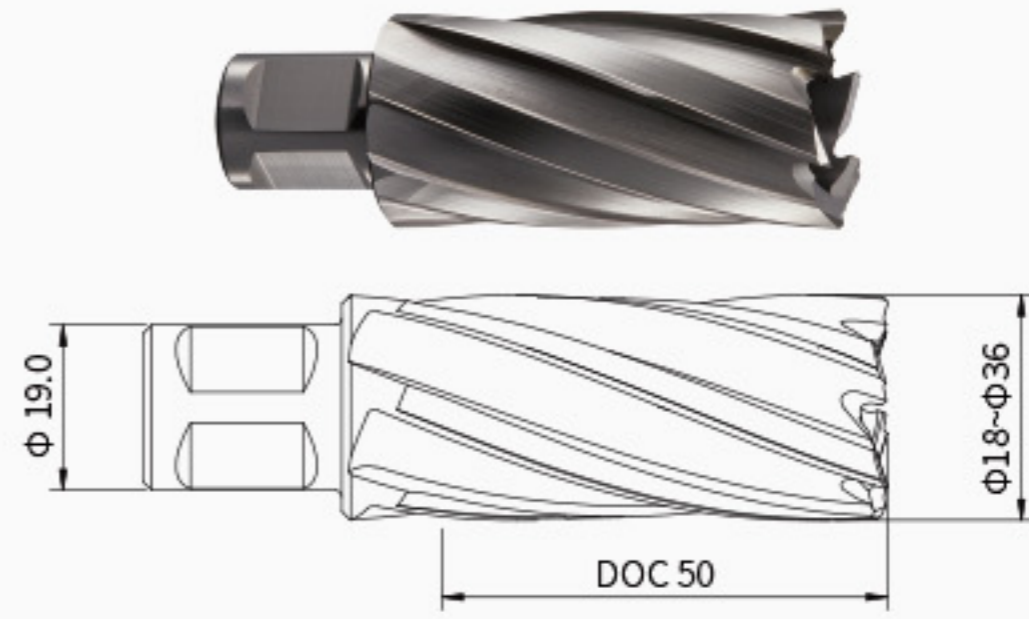

单位(Unit): mm

型号 MODEL	规格 SPECIFICATION	型号 MODEL	规格 SPECIFICATION	型号 MODEL	规格 SPECIFICATION
DRHX-40180FL	18*50	DRHX-40250FL	25*50	DRHX-40320FL	32*50
DRHX-40190FL	19*50	DRHX-40260FL	26*50	DRHX-40330FL	33*50
DRHX-40200FL	20*50	DRHX-40270FL	27*50	DRHX-40340FL	34*50
DRHX-40210FL	21*50	DRHX-40280FL	28*50	DRHX-40350FL	35*50
DRHX-40220FL	22*50	DRHX-40290FL	29*50	DRHX-40360FL	36*50
DRHX-40230FL	23*50	DRHX-40300FL	30*50		
DRHX-40240FL	24*50	DRHX-40310FL	31*50		

适配顶针 SUITABLE PILOT PIN

钻头直径 DIAMETER	匹配顶针 MATCHING PILOT PIN		
	型号 MODEL	规格 SPECIFICATION	顶针 PILOT PIN
$\Phi 18-36$	DPB-81103	7.98*103	



DRHX HIGH-SPEED STEEL RAIL CUTTER 高速钢钢轨钻

- $\Phi 19.05\text{mm}$ 柄径;
- 超硬高速钢, 性能优越;
- 专用切削刃, 切削锋利;
- 水剂冷却、油雾冷却应用;
- The diameter of shank $\Phi 19.05\text{mm}$;
- Super hard high speed steel, excellent performance;
- Specialized geometric cutting edge, make sure cutting sharp;
- Water cooling and Oil mist cooling are available.

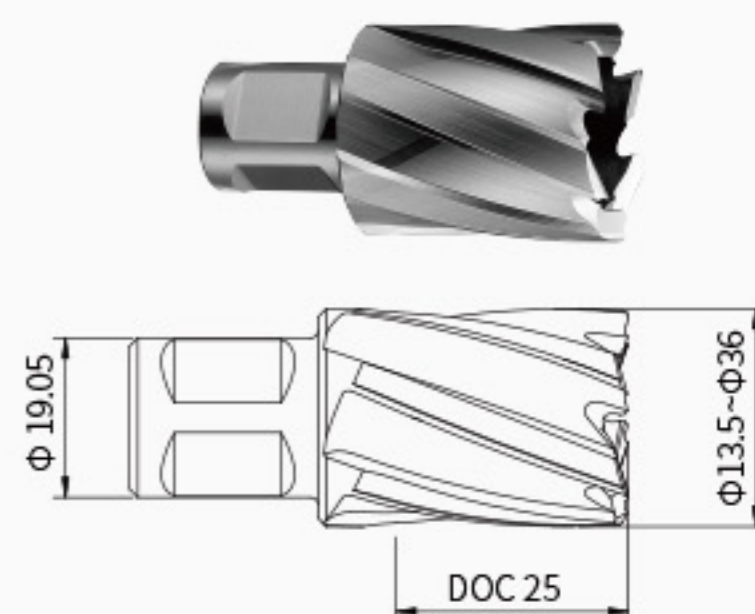

单位(Unit): mm

型号 MODEL	规格 SPECIFICATION	型号 MODEL	规格 SPECIFICATION	型号 MODEL	规格 SPECIFICATION
DRHX-20135	13.5*25	DRHX-20240	24*25	DRHX-20310	31*25
DRHX-20180	18*25	DRHX-20250	25*25	DRHX-20320	32*25
DRHX-20190	19*25	DRHX-20260	26*25	DRHX-20330	33*25
DRHX-20200	20*25	DRHX-20270	27*25	DRHX-20340	34*25
DRHX-20210	21*25	DRHX-20280	28*25	DRHX-20350	35*25
DRHX-20220	22*25	DRHX-20290	29*25	DRHX-20360	36*25
DRHX-20230	23*25	DRHX-20300	30*25		

适配顶针 SUITABLE PILOT PIN

钻头直径 DIAMETER	匹配顶针 MATCHING PILOT PIN		
	型号 MODEL	规格 SPECIFICATION	顶针 PILOT PIN
$\Phi 13.5-17$	DPB-62077	6.34*5.3*77	
$\Phi 18-36$	DPB-81077	7.98*77	

DRHX HIGH-SPEED STEEL RAIL CUTTER 高速钢钢轨钻

- $\Phi 19.05\text{mm}$ 柄径;
- 超硬高速钢, 性能优越;
- 专用切削刃, 切削锋利;
- 水剂冷却、油雾冷却应用;

- The diameter of shank $\Phi 19.05\text{mm}$;
- Super hard high speed steel, excellent performance;
- Specialized geometric cutting edge, make sure cutting sharp;
- Water cooling and Oil mist cooling are available.

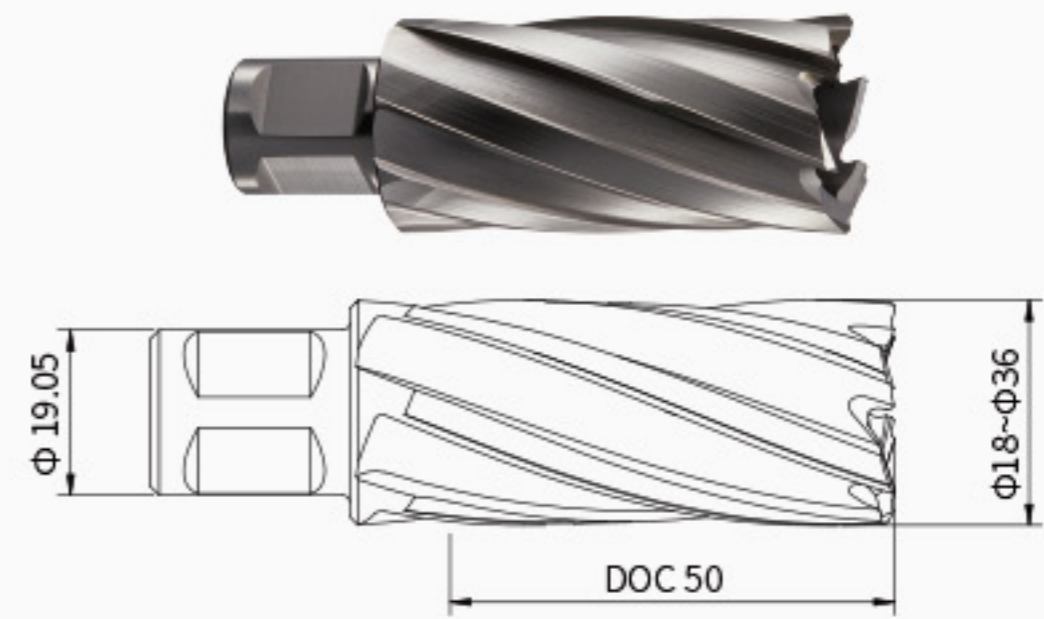

单位(Unit): mm

型号 MODEL	规格 SPECIFICATION	型号 MODEL	规格 SPECIFICATION	型号 MODEL	规格 SPECIFICATION
DRHX-40180	18*50	DRHX-40250	25*50	DRHX-40320	32*50
DRHX-40190	19*50	DRHX-40260	26*50	DRHX-40330	33*50
DRHX-40200	20*50	DRHX-40270	27*50	DRHX-40340	34*50
DRHX-40210	21*50	DRHX-40280	28*50	DRHX-40350	35*50
DRHX-40220	22*50	DRHX-40290	29*50	DRHX-40360	36*50
DRHX-40230	23*50	DRHX-40300	30*50		
DRHX-40240	24*50	DRHX-40310	31*50		

适配顶针 SUITABLE PILOT PIN

钻头直径 DIAMETER	匹配顶针 MATCHING PILOT PIN		
	型号 MODEL	规格 SPECIFICATION	顶针 PILOT PIN
$\Phi 18-36$	DPB-81103	7.98*103	

