

SKSY RAIL CUTTER WITH EXCHANGEABLE CARBIDE TIPS 可转位钢轨钻

- 圆销柄结构, 实现快装;
- 机夹式, 可转位结构, 应用更为方便与经济;
- 适合特殊钻机或刚性良好的设备;
- Round shank construction for quick clamping;
- Machine clamping type, special structure, Application is more convenient and economical;
- Suitable on special rail drills or equipment with good rigidity.

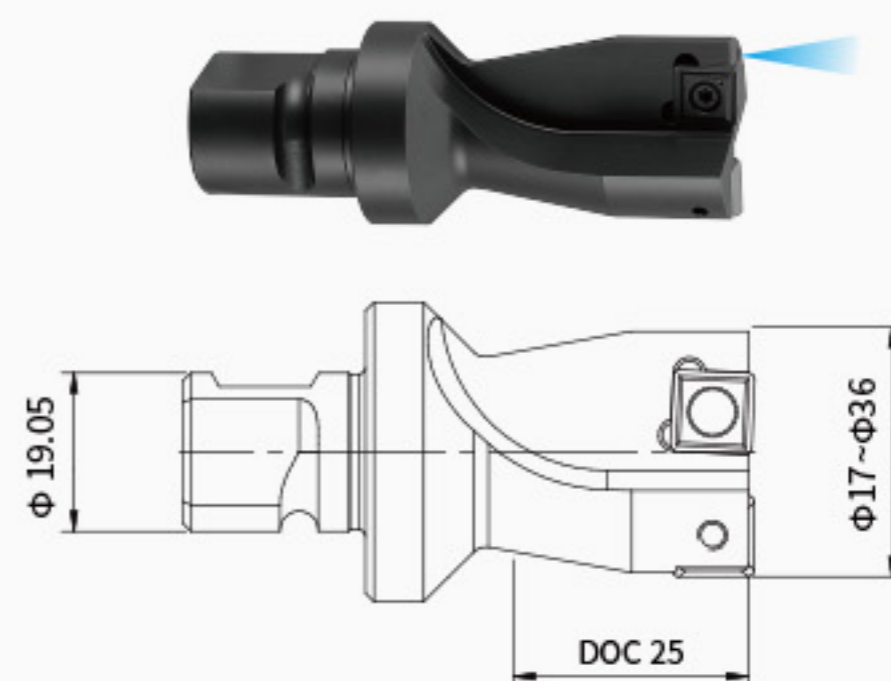

单位(Unit): mm

型号 MODEL	规格 SPECIFICATION	型号 MODEL	规格 SPECIFICATION	型号 MODEL	规格 SPECIFICATION
SKSY-20170	17*25	SKSY-20250	25*25	SKSY-20325	32.5*25
SKSY-20180	18*25	SKSY-20260	26*25	SKSY-20330	33*25
SKSY-20190	19*25	SKSY-20280	28*25	SKSY-20340	34*25
SKSY-20200	20*25	SKSY-20290	29*25	SKSY-20360	36*25
SKSY-20220	22*25	SKSY-20300	30*25		
SKSY-20240	24*25	SKSY-20320	32*25		

附件 ACCESSORIES

名称 NAME	订货号 PART NO.	规格 SPECIFICATION	使用扭矩 TORQUE	直径 DIAMETER	附件 ACCESSORIES
刀片 INSERT	2501014	6*6*2.4	-	Φ18-21	
	2501015	8*8*4	-	Φ22-27	
	2501013	10*10*4.3	-	Φ28-34	
	2501016	11.5*11.5*4.8	-	Φ35-36	
螺钉 SCREW	2102027	M2.2	0.5	Φ18-21	
	2102028	M2.5	1.0	Φ22-27	
	2102094	M3.5	2.5	Φ28-34	
	2102045	M4	3.5	Φ35-36	
扳手 WRENCH	2502012	T6	0.5	Φ18-21	
	2502011	T7	1.0	Φ22-27	
	2502010	T15	2.5	Φ28-36	