

# SRHJ HSS SPLIT-TYPE SOLID RAIL CUTTER 高速钢分体式实心钢轨钻

- $\Phi 8\text{mm}$ 和 $\Phi 13\text{mm}$ 两种柄径;
- 超硬高速钢, 高红硬性热处理工艺;
- 设有冷却引流结构, 提高冷却性能;
- 可重复修磨;
- Two shank diameters of  $\Phi 8\text{mm}$  and  $\Phi 13\text{mm}$  are available;
- Super hard High speed steel, with special heat treatment process;
- Cooling drainage structure to improve cooling performance;
- Regrinding is available.

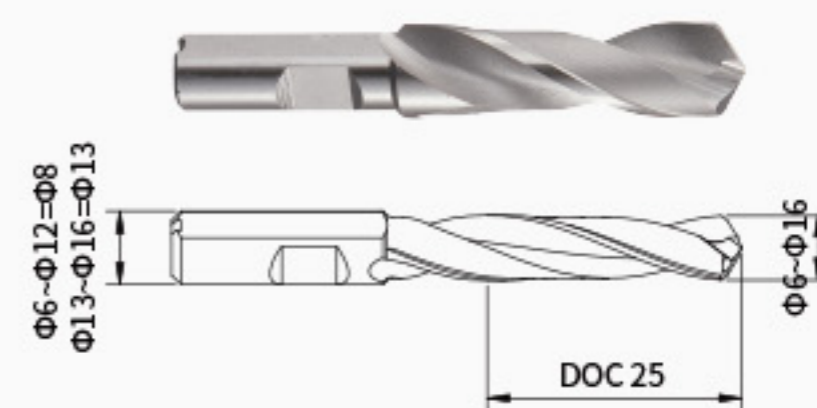

单位(Unit): mm

型号 MODEL	规格 SPECIFICATION	型号 MODEL	规格 SPECIFICATION
SRHJ-20060	6*25	SRHJ-20120	12*25
SRHJ-20080	8*25	SRHJ-20130	13*25
SRHJ-20095	9.5*25	SRHJ-20135	13.5*25
SRHJ-20098	9.8*25	SRHJ-20140	14*25
SRHJ-20100	10*25	SRHJ-20150	15*25
SRHJ-20110	11*25	SRHJ-20160	16*25

## 适配附件 ACCESSORIES

钻头直径 DIAMETER	匹配配件 ACCESSORIES				
	原订货号 ORIGINAL PART NO.	订货号 PART NO.	名称 NAME	规格 SPECIFICATION	配件 ACCESSORIES
$\Phi 6-12$	198122001	10198020090	接柄	19.05*8*35	
$\Phi 13-16$	198122003	10198020091	接柄	19.05*13*35	
		2399006	顶杆	8.4*7*22	

- $\Phi 8\text{mm}$ 和 $\Phi 13\text{mm}$ 两种柄径;
- 超硬高速钢, 高红硬性热处理工艺;
- 设有冷却引流结构, 提高冷却性能;
- 可重复修磨;

- Two shank diameters of  $\Phi 8\text{mm}$  and  $\Phi 13\text{mm}$  are available;
- Super hard High speed steel, with special heat treatment process;
- Cooling drainage structure to improve cooling performance;
- Regrinding is available.

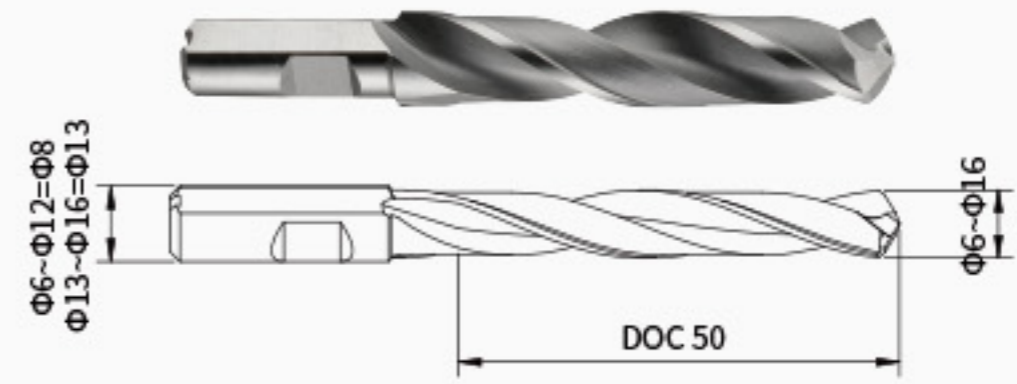

单位(Unit): mm

型号 MODEL	规格 SPECIFICATION	型号 MODEL	规格 SPECIFICATION
SRHJ-40060	6*50	SRHJ-40120	12*50
SRHJ-40080	8*50	SRHJ-40130	13*50
SRHJ-40095	9.5*50	SRHJ-40135	13.5*50
SRHJ-40098	9.8*50	SRHJ-40140	14*50
SRHJ-40100	10*50	SRHJ-40150	15*50
SRHJ-40110	11*50	SRHJ-40160	16*50

### 适配附件 ACCESSORIES

钻头直径 DIAMETER	匹配配件 ACCESSORIES				
	原订货号 ORIGINAL PART NO.	订货号 PART NO.	名称 NAME	规格 SPECIFICATION	配件 ACCESSORIES
$\Phi 6-12$	198122001	10198020090	接柄	19.05*8*35	
$\Phi 13-16$	198122003	10198020091	接柄	19.05*13*35	
		2399006	顶杆	8.4*7*22	

