

# SRHX HSS INTEGRAL TYPE SOLID RAIL CUTTER 高速钢整体式实心钢轨钻

- $\Phi 19.0\text{mm}$ 柄径;
- 超硬高速钢, 特殊两刃切削几何;
- 卓越的耐磨性与抗冲击性;
- 可重复修磨多次;

- The diameter of shank  $\Phi 19.0\text{mm}$ ;
- Super hard High speed steel, special two edges cutting geometry ;
- Excellent abrasion resistance and impact resistance;
- Regrinding is available.

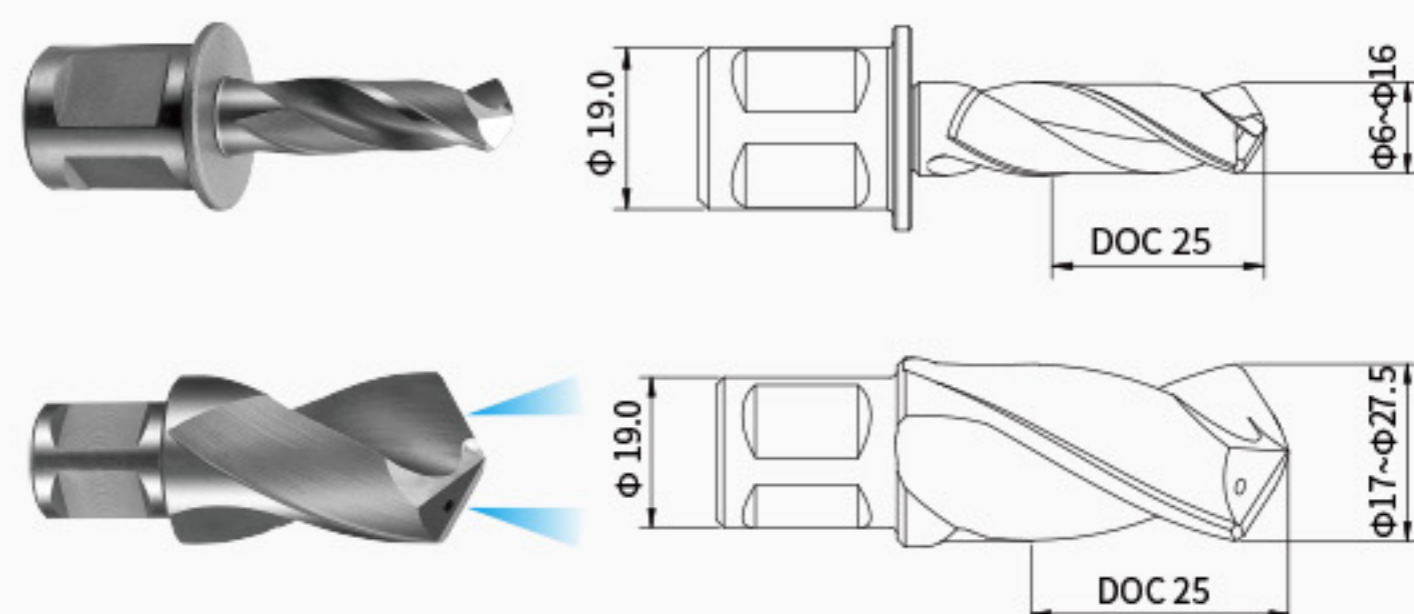

单位(Unit): mm

型号 MODEL	规格 SPECIFICATION	型号 MODEL	规格 SPECIFICATION	型号 MODEL	规格 SPECIFICATION
SRHX-20060ML	6*25	SRHX-20140ML	14*25	SRHX-20220ML	22*25
SRHX-20080ML	8*25	SRHX-20150ML	15*25	SRHX-20230ML	23*25
SRHX-20095ML	9.5*25	SRHX-20160ML	16*25	SRHX-20240ML	24*25
SRHX-20098ML	9.8*25	SRHX-20170ML	17*25	SRHX-20250ML	25*25
SRHX-20100ML	10*25	SRHX-20180ML	18*25	SRHX-20260ML	26*25
SRHX-20110ML	11*25	SRHX-20190ML	19*25	SRHX-20270ML	27*25
SRHX-20120ML	12*25	SRHX-20195ML	19.5*25	SRHX-20275ML	27.5*25
SRHX-20130ML	13*25	SRHX-20200ML	20*25		
SRHX-20135ML	13.5*25	SRHX-20210ML	21*25		

# SRHX HSS INTEGRAL TYPE SOLID RAIL CUTTER

## 高速钢整体式实心钢轨钻

- $\Phi 19.0$ mm柄径;
- 超硬高速钢, 特殊两刃切削几何;
- 卓越的耐磨性与抗冲击性;
- 可重复修磨多次;
- The diameter of shank  $\Phi 19.0$ mm;
- Super hard High speed steel, special two edges cutting geometry;
- Excellent abrasion resistance and impact resistance;
- Regrinding is available.

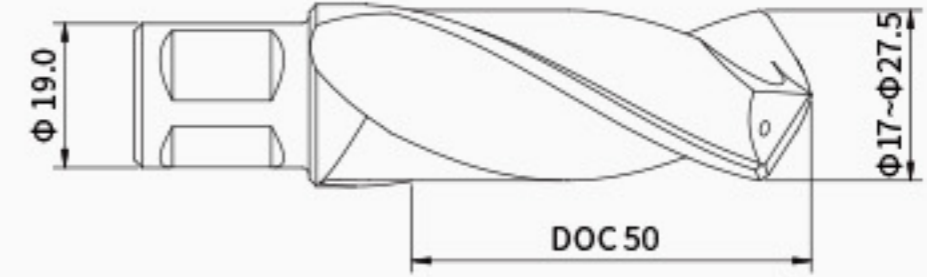

单位(Unit): mm

型号 MODEL	规格 SPECIFICATION	型号 MODEL	规格 SPECIFICATION	型号 MODEL	规格 SPECIFICATION
SRHX-40170ML	17*50	SRHX-40210ML	21*50	SRHX-40260ML	26*50
SRHX-40180ML	18*50	SRHX-40220ML	22*50	SRHX-40270ML	27*50
SRHX-40190ML	19*50	SRHX-40230ML	23*50	SRHX-40275ML	27.5*50
SRHX-40195ML	19.5*50	SRHX-40240ML	24*50		
SRHX-40200ML	20*50	SRHX-40250ML	25*50		





# SRHX HSS INTEGRAL TYPE SOLID RAIL CUTTER 高速钢整体式实心钢轨钻

- $\Phi 19.05\text{mm}$ 柄径;
- 超硬高速钢, 特殊两刃切削几何;
- 卓越的耐磨性与抗冲击性;
- 可重复修磨多次;

- The diameter of shank  $\Phi 19.05\text{mm}$ ;
- Super hard High speed steel, special two edges cutting geometry ;
- Excellent abrasion resistance and impact resistance;
- Regrinding is available.

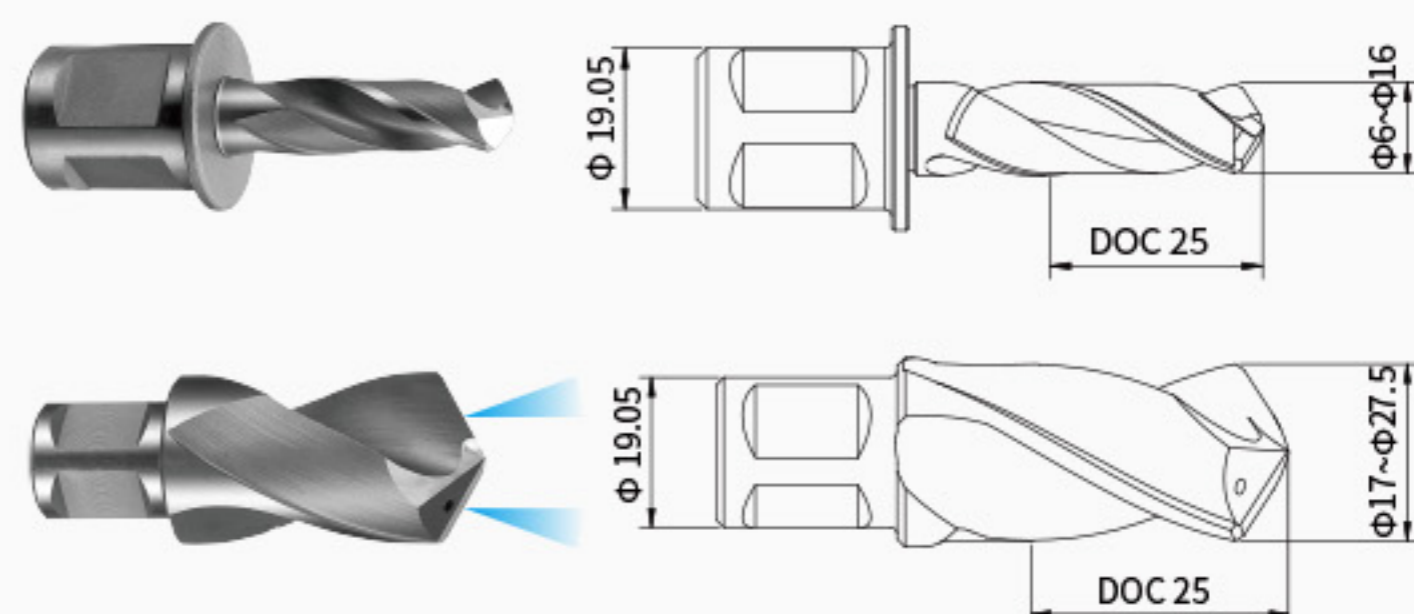

单位(Unit): mm

型号 MODEL	规格 SPECIFICATION	型号 MODEL	规格 SPECIFICATION	型号 MODEL	规格 SPECIFICATION
SRHX-20060	6*25	SRHX-20140	14*25	SRHX-20220	22*25
SRHX-20080	8*25	SRHX-20150	15*25	SRHX-20230	23*25
SRHX-20095	9.5*25	SRHX-20160	16*25	SRHX-20240	24*25
SRHX-20098	9.8*25	SRHX-20170	17*25	SRHX-20250	25*25
SRHX-20100	10*25	SRHX-20180	18*25	SRHX-20260	26*25
SRHX-20110	11*25	SRHX-20190	19*25	SRHX-20270	27*25
SRHX-20120	12*25	SRHX-20195	19.5*25	SRHX-20275	27.5*25
SRHX-20130	13*25	SRHX-20200	20*25		
SRHX-20135	13.5*25	SRHX-20210	21*25		

# SRHX HSS INTEGRAL TYPE SOLID RAIL CUTTER

## 高速钢整体式实心钢轨钻

- $\Phi 19.05\text{mm}$ 柄径;
- 超硬高速钢, 特殊两刃切削几何;
- 卓越的耐磨性与抗冲击性;
- 可重复修磨多次;
- The diameter of shank  $\Phi 19.05\text{mm}$ ;
- Super hard High speed steel, special two edges cutting geometry;
- Excellent abrasion resistance and impact resistance;
- Regrinding is available.

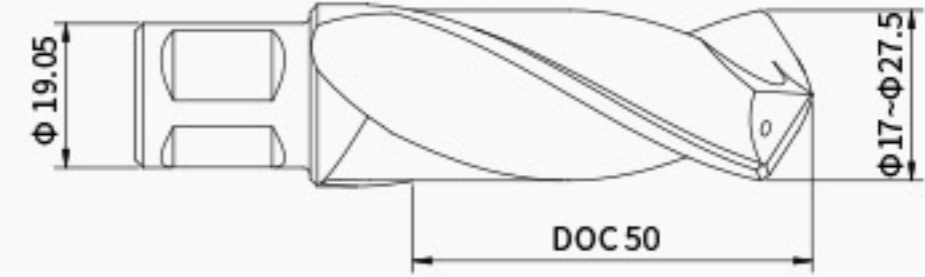

单位(Unit): mm

型号 MODEL	规格 SPECIFICATION	型号 MODEL	规格 SPECIFICATION	型号 MODEL	规格 SPECIFICATION
SRHX-40170	17*50	SRHX-40210	21*50	SRHX-40260	26*50
SRHX-40180	18*50	SRHX-40220	22*50	SRHX-40270	27*50
SRHX-40190	19*50	SRHX-40230	23*50	SRHX-40275	27.5*50
SRHX-40195	19.5*50	SRHX-40240	24*50		
SRHX-40200	20*50	SRHX-40250	25*50		

