

TOOL HOLDER 夹具

DJXY 内冷夹具 DJXY ARBOR WITH MORSE TOOL HOLDER, CLAMPING WITH SCREWS, INTERNAL COOLING

- 适合通用柄、直角柄钢板钻；
- 莫氏锥柄；
- 冷却环供液，内冷型；
- 设有切深50、75、100三种系列。
- Suitable to Universal shank, 19.05mm Weldon shank;
- Morse taper shank;
- Cooling ring, internal cooling;
- There are three series of cutting depth 50, 75 and 100.

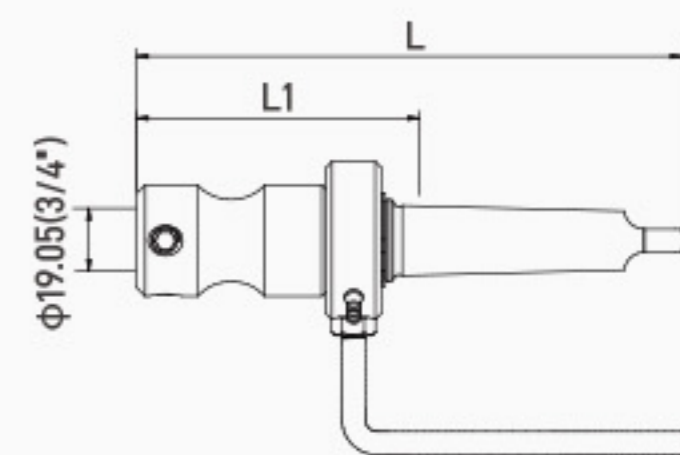

单位(Unit): mm

订货号 PART NO.	原订货号 ORIGINAL PART NO.	型号 TYPE	规格 SIZE	切深 D.O.C	夹持规格 CLAMPING SIZE	连接柄规格 MORSE TAPPER	总长L OVERALL LENGTH	沿伸长L1 EXTENSION
10198030126	198103004	DJXY-50-MT2	MT2*50*19.05	50	19.05mm(3/4")	MT2	168	93
10198030127	198103005	DJXY-50-MT3	MT3*50*19.05	50	19.05mm(3/4")	MT3	187	93
10198030128	198103006	DJXY-50-MT4	MT4*50*19.05	50	19.05mm(3/4")	MT4	212	95
10198030129	198103074	DJXY-50-MT5	MT5*50*19.05	50	19.05mm(3/4")	MT5	240	90
10198030137	198103007	DJXY-75-MT3	MT3*75*19.05	75	19.05mm(3/4")	MT3	203	109
10198030138	198103008	DJXY-75-MT4	MT4*75*19.05	75	19.05mm(3/4")	MT4	214	97
10198030139	198103025	DJXY-75-MT5	MT5*75*19.05	75	19.05mm(3/4")	MT5	245	95
10198030104	198103075	DJXY-100-MT2	MT2*100*19.05	100	19.05mm(3/4")	MT2	223	148
10198030105	198103009	DJXY-100-MT3	MT3*100*19.05	100	19.05mm(3/4")	MT3	233	139
10198030106	198103026	DJXY-100-MT4	MT4*100*19.05	100	19.05mm(3/4")	MT4	238	121
10198030107	198103027	DJXY-100-MT5	MT5*100*19.05	100	19.05mm(3/4")	MT5	250	100

DJPY 内冷夹具 DJPY ARBOR WITH MORSE TOOL HOLDER, CLAMPING WITH SCREWS, INTERNAL COOLING

- 适合P型直角柄钢板钻；
- 莫氏锥柄；
- 冷却环供液，内冷型；
- 设有切深50、75、100三种系列。
- Suitable to 31.75mm Weldon shank;
- Morse taper shank;
- Cooling ring, internal cooling;
- There are three series of cutting depth 50, 75 and 100.

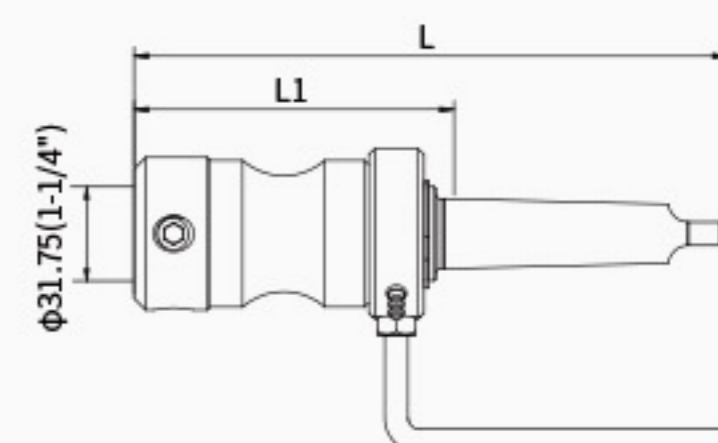

单位(Unit): mm

订货号 PART NO.	原订货号 ORIGINAL PART NO.	型号 TYPE	规格 SIZE	切深 D.O.C	夹持规格 CLAMPING SIZE	连接柄规格 MORSE TAPPER	总长L OVERALL LENGTH	沿伸长L1 EXTENSION
10198030057	198103001	DJPY-50-MT3	MT3*50*31.75	50	31.75mm(1-1/4")	MT3	202	108
10198030058	198103002	DJPY-50-MT4	MT4*50*31.75	50	31.75mm(1-1/4")	MT4	225	108
10198030059	198103028	DJPY-75-MT3	MT3*75*31.75	75	31.75mm(1-1/4")	MT3	215	121
10198030060	198103003	DJPY-75-MT4	MT4*75*31.75	75	31.75mm(1-1/4")	MT4	235	118
10198030061	198103029	DJPY-75-MT5	MT5*75*31.75	75	31.75mm(1-1/4")	MT5	264	114
10198030046	198103032	DJPY-100-MT3	MT3*100*31.75	100	31.75mm(1-1/4")	MT3	248	154
10198030047	198103030	DJPY-100-MT4	MT4*100*31.75	100	31.75mm(1-1/4")	MT4	250	133
10198030048	198103031	DJPY-100-MT5	MT5*100*31.75	100	31.75mm(1-1/4")	MT5	269	120
10198030049	198103094	DJPY-100-MT6	MT6*100*31.75	100	31.75mm(1-1/4")	MT6	324	114

TOOL HOLDER

TOOL HOLDER 夹具

DJXK 内冷快装夹具 DJXK ARBOR WITH MORSE TOOL HOLDER, QUICK-IN CLAMPING, INTERNAL COOLING

- 适合直径小于等于45mm的通用柄、直角柄钢板钻；
- 莫氏锥柄；
- 免工具快速夹紧；
- 冷却环供液，内部冷却；
- Suitable to the diameter less than 45mm Universal shank, 19.05mm Weldon shank;
- Morse taper shank;
- Quick-in clamping;

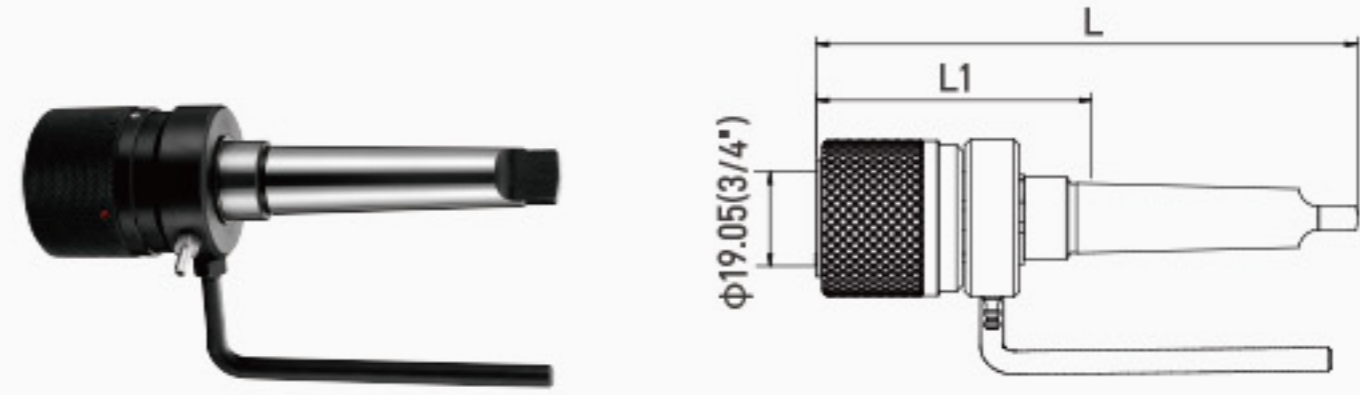

单位(Unit): mm

订货号 PART NO.	原订货号 ORIGINAL PART NO.	型号 TYPE	规格 SIZE	切深 D.O.C	夹持规格 CLAMPING SIZE	连接柄规格 MORSE TAPPER	总长L OVERALL LENGTH	沿伸长L1 EXTENSION
10198030068	198103065	DJXK-50-MT2	MT2*50*19.05	50	19.05mm(3/4")	MT2	168	93
10198030069	198103068	DJXK-50-MT3	MT3*50*19.05	50	19.05mm(3/4")	MT3	185	91

快装内冷型夹具, 安装示意图 INSTALLATION DIAGRAM OF QUCIK-IN TOOL HOLDER



装入 INTO

步骤1: 按箭头所示旋转夹紧套, 将“红色标记”旋转到“白色标记”处, 钢板钻刀柄上的扁对着白点, 装入夹具中。

Step 1: Rotating tool holder sleeve as the arrow shows, and rotating the “red marker” to the “white marker”, then the annular cutter shank into the tool holder.



夹紧 CLAMP

步骤2: 钢板钻刀柄装入夹具后, 放松夹紧套, 左右微晃, 使“绿色标记”对应“白色标记”处, 即已自动固定。

Step 2: Rotating the annular cutter, the annular cutter shank into the tool holder, loosening the tool holder sleeve, and the “green marker” shall be corresponding to the “white marker”, namely it has be fixed automatically.



卸下 REMOVE

步骤3: 按箭头所示旋转夹紧套, 将“红色标记”旋转到“白色标记”处, 即可拆卸钢板钻。

Step 3: Rotating tool holder sleeve as arrow shows, rotating from the “red marker” to the “white marker”, then the annular cutter can be removed.

TOOL HOLDER 夹具

DJJY 内冷J形柄夹具 J-TYPE INTERNAL COOLING

- 适合J型削平柄钢板钻;
- 莫氏锥柄;
- 冷却环供液, 内部冷却;
- 设有切深75、100两种系列;
- Suitable to parallel shank (J type);
- Morse taper shank;
- Cooling ring, internal cooling;
- There are three series of cutting depth 75 and 100.

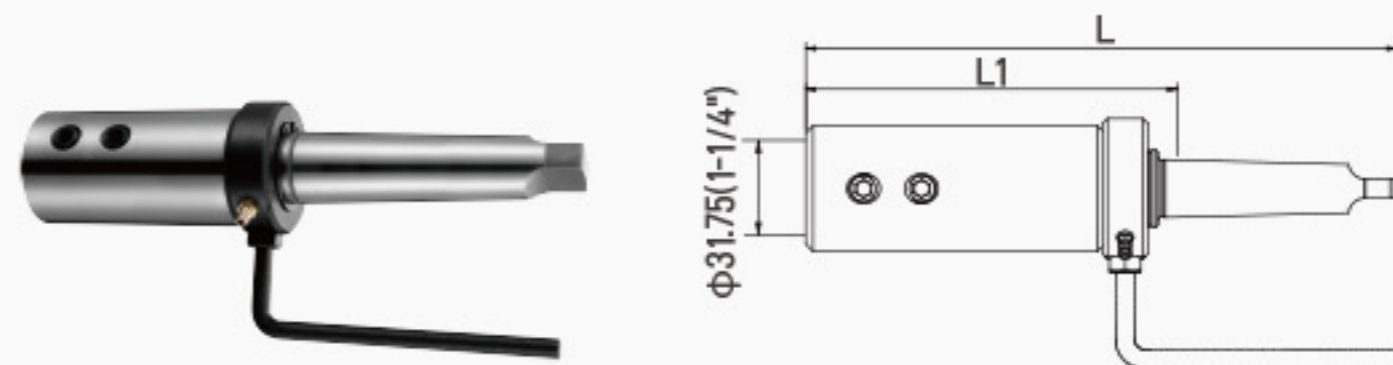

单位(Unit): mm

订货号 PART NO.	原订货号 ORIGINAL PART NO.	型号 TYPE	规格 SIZE	切深 D.O.C	夹持规格 CLAMPING SIZE	连接柄规格 MORSE TAPPER	总长L OVERALL LENGTH	沿伸长L1 EXTENSION
10198030006	198103040	DJJY-75-MT3	MT3*75*31.75	75	31.75mm(1-1/4")	MT3	245	151
10198030007	198103041	DJJY-75-MT4	MT4*75*31.75	75	31.75mm(1-1/4")	MT4	250	133
10198030008	198103077	DJJY-75-MT5	MT5*75*31.75	75	31.75mm(1-1/4")	MT5	262	112
10198030005	198103125	DJJY-100-MT5	MT5*100*31.75	100	31.75mm(1-1/4")	MT5	287	137

DJXZ 内冷夹具 DJXZ ARBOR WITH MORSE TOOL HOLDER, CLAMPING WITH SCREWS, INTERNAL CENTER

- 适合通用柄、直角柄钢板钻;
- 莫氏锥柄;
- 锥柄供液, 内冷型;
- Suitable to Universal shank, 19.05mm Weldon shank;
- Morse taper shank;
- Cooling ring, internal cooling.

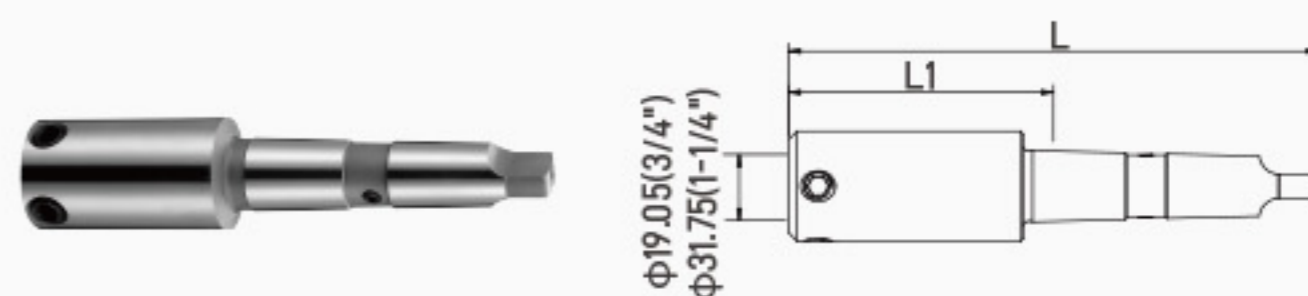

单位(Unit): mm

订货号 PART NO.	原订货号 ORIGINAL PART NO.	型号 TYPE	规格 SIZE	切深 D.O.C	夹持规格 CLAMPING SIZE	连接柄规格 MORSE TAPPER	总长L OVERALL LENGTH	沿伸长L1 EXTENSION
10198030142	198103045	DJXZ-50-MT3	MT3*50*19.05	50	19.05mm(3/4")	MT3	178	84
10198030062	198103043	DJPZ-50-MT3	MT3*50*31.75	50	31.75mm(1-1/4")	MT3	190	96

DJXW 外冷夹具 DJXW ARBOR WITH MORSE TOOL HOLDER, CLAMPING WITH SCREWS, OUTER COLLING COOLING

- 适合夹持通用柄与直角柄钢板钻;
- 莫氏锥柄;
- Suitable to Universal shank, 19.05mm Weldon shank;
- Morse taper shank.

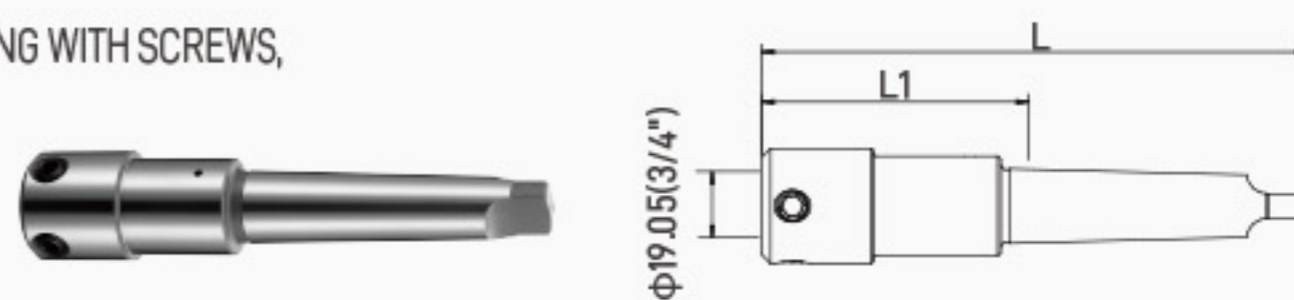

单位(Unit): mm

订货号 PART NO.	原订货号 ORIGINAL PART NO.	型号 TYPE	规格 SIZE	切深 D.O.C	夹持规格 CLAMPING SIZE	连接柄规格 MORSE TAPPER	总长L OVERALL LENGTH	沿伸长L1 EXTENSION
10198030085	198103013	DJXW-50-MT2	MT2*50*19.05	50	19.05mm(3/4")	MT2	162	87
10198030087	198103014	DJXW-50-MT3	MT3*50*19.05	50	19.05mm(3/4")	MT3	176	82
10198030089	198103015	DJXW-50-MT4	MT4*50*19.05	50	19.05mm(3/4")	MT4	189	72
10198030091	198103016	DJXW-50-MT5	MT5*50*19.05	50	19.05mm(3/4")	MT5	206	57
10198030092	198103092	DJXW-50-MT6	MT6*50*19.05	50	19.05mm(3/4")	MT6	272	62
10198030095	198103086	DJXW-75-MT3	MT3*75*19.05	75	19.05mm(3/4")	MT3	202	108
10198030096	198103042	DJXW-75-MT4	MT4*75*19.05	75	19.05mm(3/4")	MT4	210	93

TOOL HOLDER

TOOL HOLDER 夹具

DJPW 外冷夹具

DJPW ARBOR WITH MORSE TOOL HOLDER, CLAMPING WITH SCREWS,
OUTER COLLING COOLING

- 适合P型直角柄钢板钻;
- 莫氏锥柄;
- Suitable to 31.75mm Weldon shank;
- Morse taper shank.

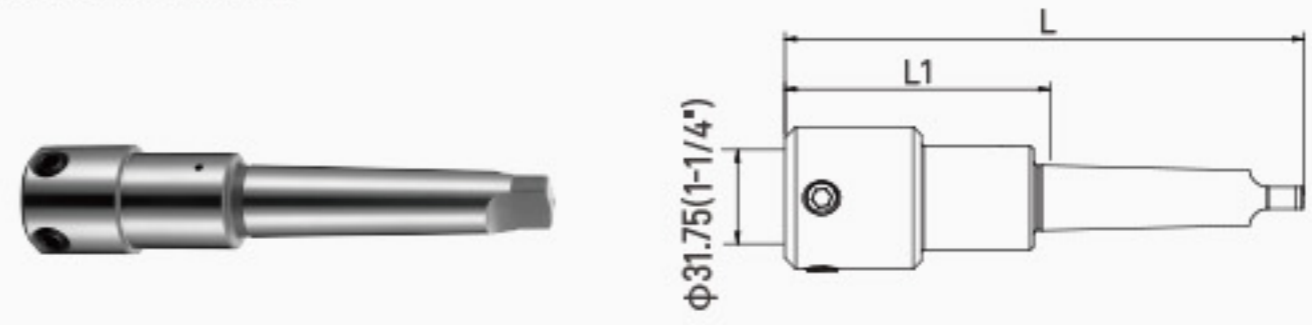

单位(Unit): mm

订货号 PART NO.	原订货号 ORIGINAL PART NO.	型号 TYPE	规格 SIZE	切深 D.O.C	夹持规格 CLAMPING SIZE	连接柄规格 MORSE TAPPER	总长L OVERALL LENGTH	沿伸长L1 EXTENSION
10198030038	198103010	DJPW-50-MT3	MT3*50*31.75	50	31.75mm(1-1/4")	MT3	172	78
10198030039	198103011	DJPW-50-MT4	MT4*50*31.75	50	31.75mm(1-1/4")	MT4	204	86
10198030040	198103012	DJPW-50-MT5	MT5*50*31.75	50	31.75mm(1-1/4")	MT5	217	68
10198030042	198103085	DJPW-75-MT3	MT3*75*31.75	75	31.75mm(1-1/4")	MT3	214	120
10198030043	198103059	DJPW-75-MT5	MT5*75*31.75	75	31.75mm(1-1/4")	MT5	228	79

夹具弹簧

THE SPRING OF TOOL HOLDER



单位(Unit): mm

订货号 PART NO.	规格 SIZE	匹配夹具型号 PART NO. OF TOOL HOLDER
2106004	Φ9.8×125	DJXW-50-MT2
2106005	Φ9.8×133	DJXY-50-MT2 DJXK-50-MT2
2106006	Φ13×135	DJXW-50-MT3 DJPW-50-MT3
2106007	Φ13×150	DJXY-50-MT3 DJPW-50-MT5 DJPY-50-MT3 DJXY-50-MT4 DJXW-50-MT4 DJPY-50-MT4 DJXW-50-MT5 DJXK-50-MT3
2106008	Φ14.1×164	DJXY-75-MT3 DJPY-75-MT3 DJJY-75-MT3 DJXY-75-MT4 DJPY-75-MT4 DJJY-75-MT4 DJXY-75-MT5 DJPY-75-MT5
2106009	Φ14.1×195	DJXY-100-MT3 DJXY-100-MT4 DJPY-100-MT4 DJXY-100-MT5 DJPY-100-MT5 DJXY-100-MT6 DJPY-100-MT6
2106022	Φ16.4×66	DJXW-25-1/2-20UNF
2106023	Φ16.4×115	DJXW-50-1/2-20UNF
2106028	Φ13×135	DJXZ-50-MT3 DJPZ-50-MT3

螺钉

SCREW



单位(Unit): mm

订货号 PART NO.	规格 SIZE	匹配夹具型号 PART NO. OF TOOL HOLDER
2102006	M10×10	DJXW-50-MT2 DJXY-50-MT2 DJXW-50-MT3 DJXZ-50-MT3 DJXY-50-MT3 DJXY-50-MT4 DJXW-50-MT4 DJXW-50-MT5 DJXY-75-MT3 DJXY-75-MT4 DJXY-75-MT5 DJXY-100-MT3 DJXY-100-MT4 DJXY-100-MT5
2102007	M12×12	DJPW-50-MT3 DJPW-50-MT4 DJPZ-50-MT3 DJPW-50-MT5 DJPY-50-MT3 DJPY-50-MT4 DJPY-75-MT3 DJJY-75-MT3 DJPY-75-MT4 DJJY-75-MT4 DJPY-75-MT5 DJPY-100-MT4 DJPY-100-MT5 DJXW-50-MT6 DJPY-100-MT6
2102030	M8×8	DJXW-25-1/2-20UNF DJXW-50-1/2-20UNF