

JR-HF REBAR CUTTER 钢筋切割刀

- SDS柄;
- 建工专用硬质合金刀片;
- 磨制切削刃, 切削锋利轻快。
- SDS shank;
- Special carbide tips for construction;
- Grinding cutting edge, ensure drilling process sharp and brisk.

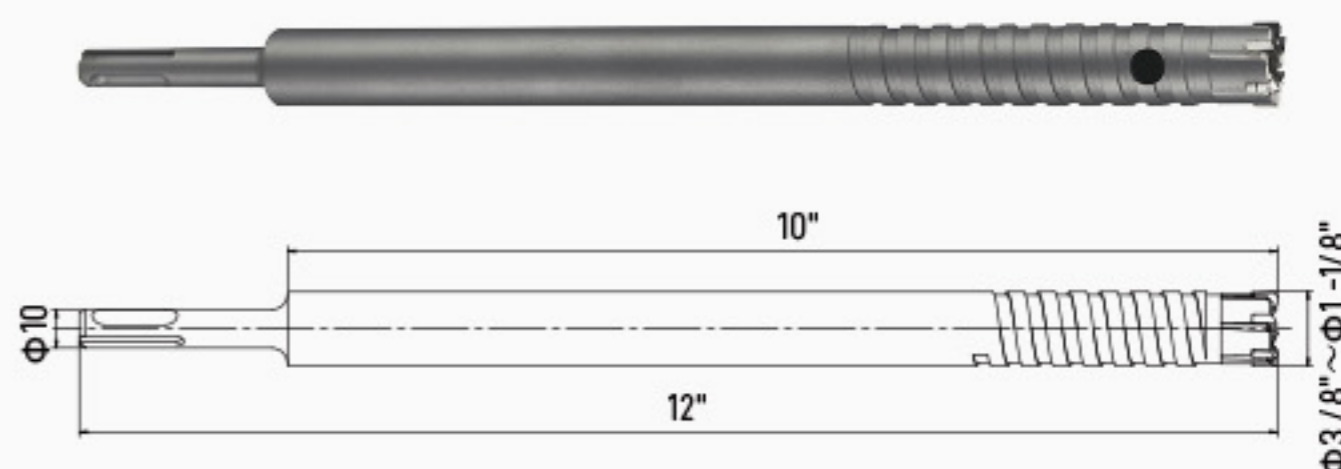

单位(Unit): inch

型号 MODEL	规格 SPECIFICATION	型号 MODEL	规格 SPECIFICATION	型号 MODEL	规格 SPECIFICATION
JR-HF-0095	3/8**10**12"	JR-HF-0158	5/8**10**12"	JR-HF-0222	7/8**10**12"
JR-HF-0111	7/16**10**12"	JR-HF-0174	11/16**10**12"	JR-HF-0254	1**10**12"
JR-HF-0127	1/2**10**12"	JR-HF-0190	3/4**10**12"	JR-HF-0285	1-1/8**10**12"
JR-HF-0142	9/16**10**12"	JR-HF-0206	13/16**10**12"		

JR-SF REBAR CUTTER 钢筋切割刀

- S型三角柄;
- 建工专用硬质合金刀片;
- 磨制切削刃, 切削锋利轻快。
- S type triangle shank;
- Special carbide tips for construction;
- Grinding cutting edge, ensure drilling process sharp and brisk.

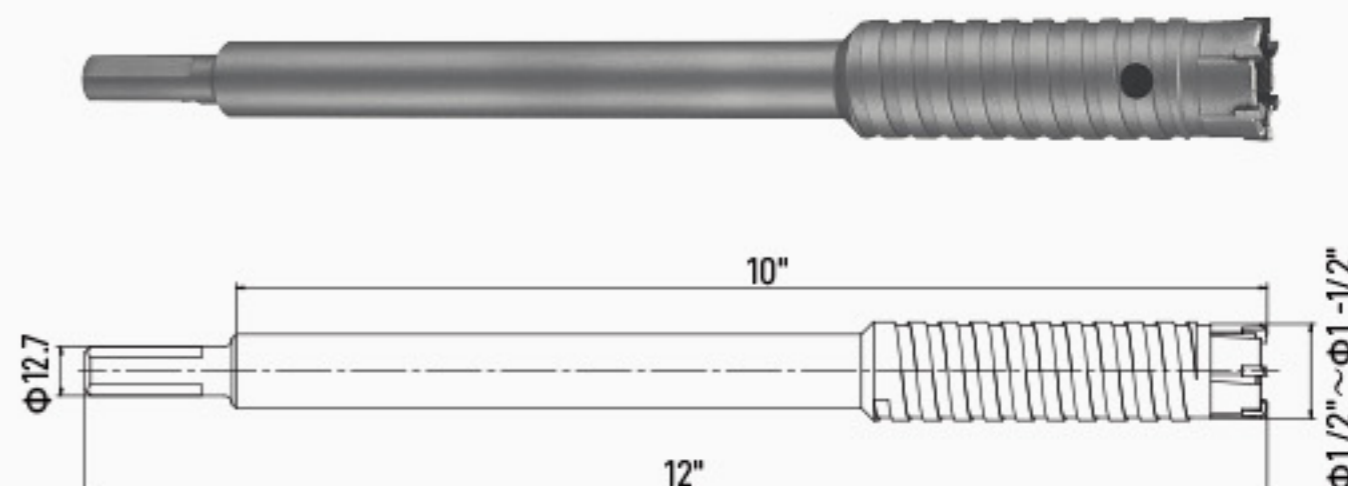

单位(Unit): inch

型号 MODEL	规格 SPECIFICATION	型号 MODEL	规格 SPECIFICATION	型号 MODEL	规格 SPECIFICATION
JR-SF-0127	1/2**10**12"	JR-SF-0254	1**10**12"	JR-SF-0381	1-1/2**10**12"
JR-SF-0158	5/8**10**12"	JR-SF-0285	1-1/8**10**12"		
JR-SF-0190	3/4**10**12"	JR-SF-0317	1-1/4**10**12"		
JR-SF-0222	7/8**10**12"	JR-SF-0349	1-3/8**10**12"		