

C30-NQC

CARBIDE Q TYPE COUNTERSINK WITH CYLINDRICAL SHANK 硬质合金Q型圆柱柄铰钻

- 特殊槽型, 刃口锋利
- Special groove, sharp edge

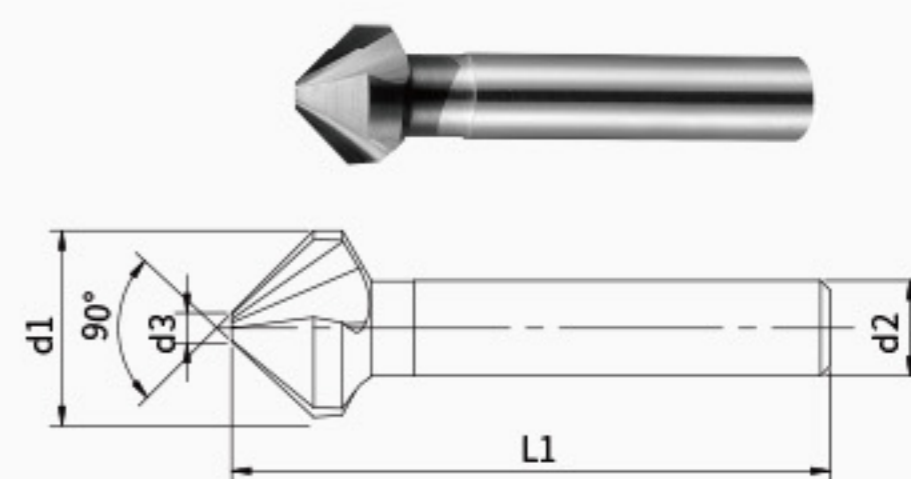

单位(Unit): mm

型号 MODEL	原型号 ORIGINAL MODEL	d1	d3	L1	d2	DIN74	
						AF	BF
C30-NQC-0063	TGTQ-305	6.3	1.5	45	5	M3	—
C30-NQC-0083	TGTQ-309	8.3	2	50	6	M4	—
C30-NQC-0104	TGTQ-312	10.4	2.5	50	6	—	M5
C30-NQC-0124	TGTQ-314	12.4	2.8	56	8	—	M6
C30-NQC-0165	TGTQ-317	16.5	3.2	60	10	—	M8
C30-NQC-0205	TGTQ-319	20.5	3.5	63	10	—	M10
C30-NQC-0250	TGTQ-321	25	3.8	67	10	—	M12
C30-NQC-0310	TGTQ-325	31	4.2	71	12	—	—

C30-NQH

CARBIDE Q TYPE COUNTERSINK WITH CYLINDRICAL SHANK (HARD CUTTING) 硬质合金Q型圆柱柄铰钻 (硬切削)

- 适用大于HRC30的被加工材料
- 硬材料专用切削几何
- Applicable to processed materials HRC more than 30
- Special cutting geometry for hard materials

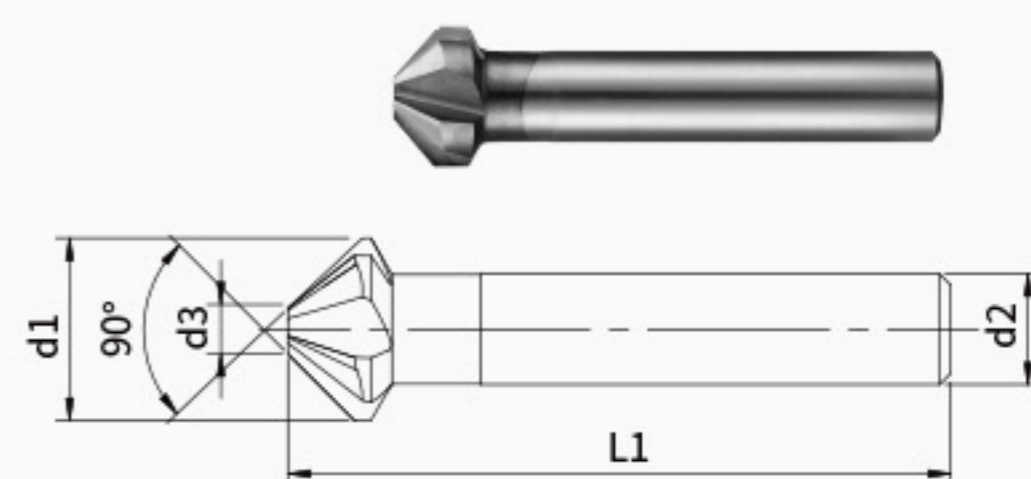

单位(Unit): mm

型号 MODEL	原型号 ORIGINAL MODEL	d1	d3	L1	d2
C30-NQH-0104	TYTQ-412	10.4	4	46	8
C30-NQH-0124	TYTQ-514	12.4	4	56	8
C30-NQH-0165	TYTQ-517	16.5	4.5	60	10
C30-NQH-0205	TYTQ-519	20.5	5	63	10
C30-NQH-0250	TYTQ-521	25	5.5	67	10
C30-NQH-0310	TYTQ-525	31	6	71	12

