

# SIAS CONICAL DRILL WITH SPIRAL FLUTE AND TRIANGLE SHANK 三角柄螺旋槽伞形钻

- 优质高速钢
- CNC磨削, 出色的刃口质量
- 可PVD涂层, 升级性能
- 根据钻孔直径选择伞形钻的规格位推荐钻削厚度 $\leq 5\text{mm}$
- High quality HSS
- CNC grinding, excellent edge quality
- PVD coating is available, it can improve performance
- Choose the SPEC position of conical drill according to the diameter of drilling  
Recommended cutting speed  $\leq 5\text{mm}$

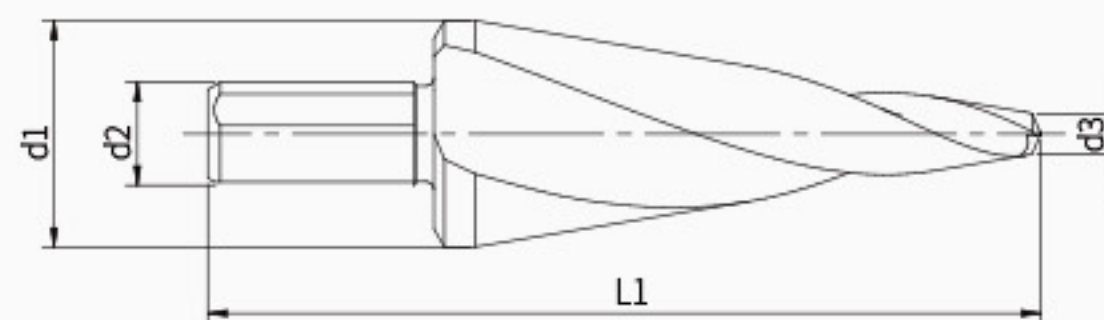

单位(Unit): mm

	型号 MODEL	规格 SIZE	d3	d1	d2	L1
	SIAS-501	4*20*8*71	4	20	8	71

	型号 MODEL	规格 SIZE	d3	d1	d2	L1
	SIAS-502	5*31*10*103	5	31	10	103



# SIHS CONICAL DRILL WITH STRAIGHT FLUTE AND TRIANGLE SHANK 三角柄直槽伞形钻

- 优质高速钢
- CNC磨削, 出色的刃口质量
- 可PVD涂层, 升级性能
- 根据钻孔直径选择伞形钻的规格位推荐钻削厚度 ≤ 5mm
- High quality HSS
- CNC grinding, excellent edge quality
- PVD coating is available, it can improve performance
- Choose the SPEC position of conical drill according to the diameter of drilling  
Recommended cutting speed ≤ 5mm

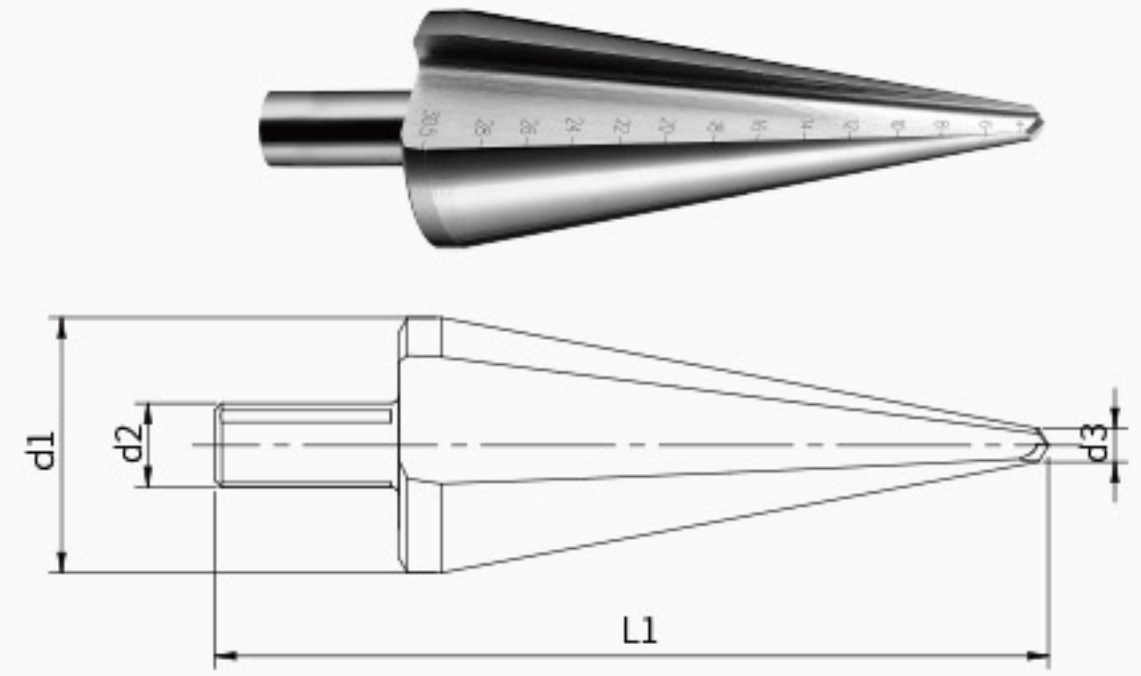

单位(Unit): mm

型号 MODEL	规格 SIZE	d3	d1	d2	L1
SIHS-105	3*14*6*60	3	14	6	60

型号 MODEL	规格 SIZE	d3	d1	d2	L1
SIHS-101	8*20*8*62	8	20	8	62

型号 MODEL	规格 SIZE	d3	d1	d2	L1
SIHS-102	16*30.5*10*72	16	30.5	10	72

型号 MODEL	规格 SIZE	d3	d1	d2	L1
SIHS-103	4*30.5*10*100	4	30.5	10	100

型号 MODEL	规格 SIZE	d3	d1	d2	L1
SIHS-104	26*40*12*83	26	40	12	83

