

DB-35 BRUSHLESS MAGNETIC DRILLING MACHINE 无刷磁座钻机

- 高速大功率无刷电机, 动力强劲, 免维护, 长寿命
- 六档电子调速, 满足不同规格需求
- 负载恒速, 提高钻孔效率, 更长钻头寿命
- 更适用于涂层钢板钻
- 正反转功能, 可用于攻丝
- High speed high-power brushless motor, powerful, maintenance free, long service life.
- six-speed electronic speed regulation to meet different specifications.
- Constant speed under load, improving drilling efficiency and extending the life of the drill bits.
- More suitable for coated annular cutter.
- Forward and reverse rotation function, can be used for tapping.

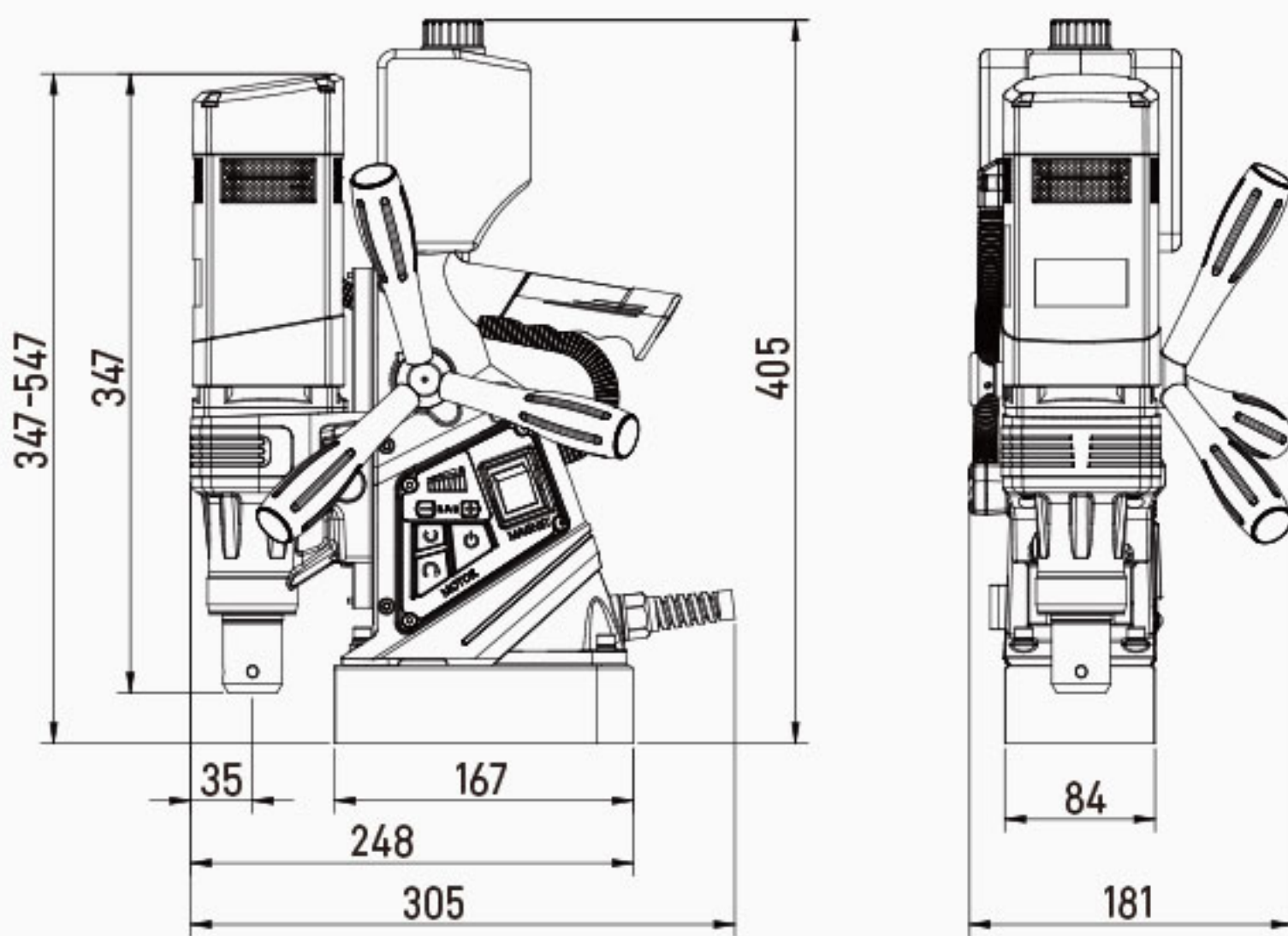

AC220V~240V 50~60HZ

额定输入功率 RATED INPUT POWER	1600W	钢板钻钻孔直径 THE DIAMETER RANGE OF ANNULAR CUTTER	≤ ϕ 35mm	磁座半吸 MAGNETIC BASE SEMI-SUCTION	✓
磁座吸力 MAGNETIC SUCTION	10000N	钢板钻钻孔深度 THE DRILLING DEPTH RANGE OF ANNULAR CUTTER	≤50mm	吸力指示 SUCTION FORCE INDICATION	✓
行程 STROKE	120mm	麻花钻直径 THE DIAMETER RANGE OF TWIST DRILL	≤ ϕ 13mm	电机缓启动 MOTOR SLOW START	✓
主轴可调高度 MAINSHAFT ADJUSTABLE HEIGHT	95mm	攻丝规格 TAPPING SPECIFICATIONS	≤M14	主电机过流保护 MAIN MOTOR CURRENT PROTECTION	✓
主轴接口类型 SPINDLE INTERFACE TYPE	ϕ 19.05mm	重量 WEIGHT	10.5KG	滑板锁止 SLIDING PLATE LOCKING	✓
磁座尺寸 MAGNETIC BASE SIZE	167*84*44mm	额定转速 RATED SPEED	Max 900rpm	电机正反转 MOTOR FORWARD AND REVERSE ROTATION	✓
外形尺寸 MACHINE SIZE	304*181*347(547)mm			六档电子调速 SIX-SPEED ELECTRONIC SPEED	✓
最小钢板厚度 THE MIN PROCESSING THICKNESS	10mm			负载恒速 CONSTANT SPEED UNDER LOAD	✓

主要配件: 冷却壶 / 扳手 / 安全带等。MAIN ACCESSORIES: COOLING POT / WRENCH / SAFETY STRAP, ETC.

可选电源插头类型 OPTIONAL POWER PLUG TYPE

AC 220~240V					AC 110~127V	
英标插头 ENGLAND STANDARD PLUG	澳标插头 AUSTRALIA STANDARD PLUG	欧标插头 EUROP STANDARD PLUG	国标插头 CHINA STANDARD PLUG	工业插头 INDUSTRIAL PLUG	美标插头 AMERICA STANDARD PLUG	工业插头 INDUSTRIAL PLUG



DB-50 BRUSHLESS MAGNETIC DRILLING MACHINE 无刷磁座钻机

- 高速大功率无刷电机, 动力强劲, 免维护, 长寿命
- 六档电子调速, 满足不同规格需求
- 负载恒速, 提高钻孔效率, 更长钻头寿命
- 更适用于涂层钢板钻
- 正反转功能, 可用于攻丝
- High speed high-power brushless motor, powerful, maintenance free, long service life.
- six-speed electronic speed regulation to meet different specifications.
- Constant speed under load, improving drilling efficiency and extending the life of the drill bits.
- More suitable for coated annular cutter.
- Forward and reverse rotation function, can be used for tapping.

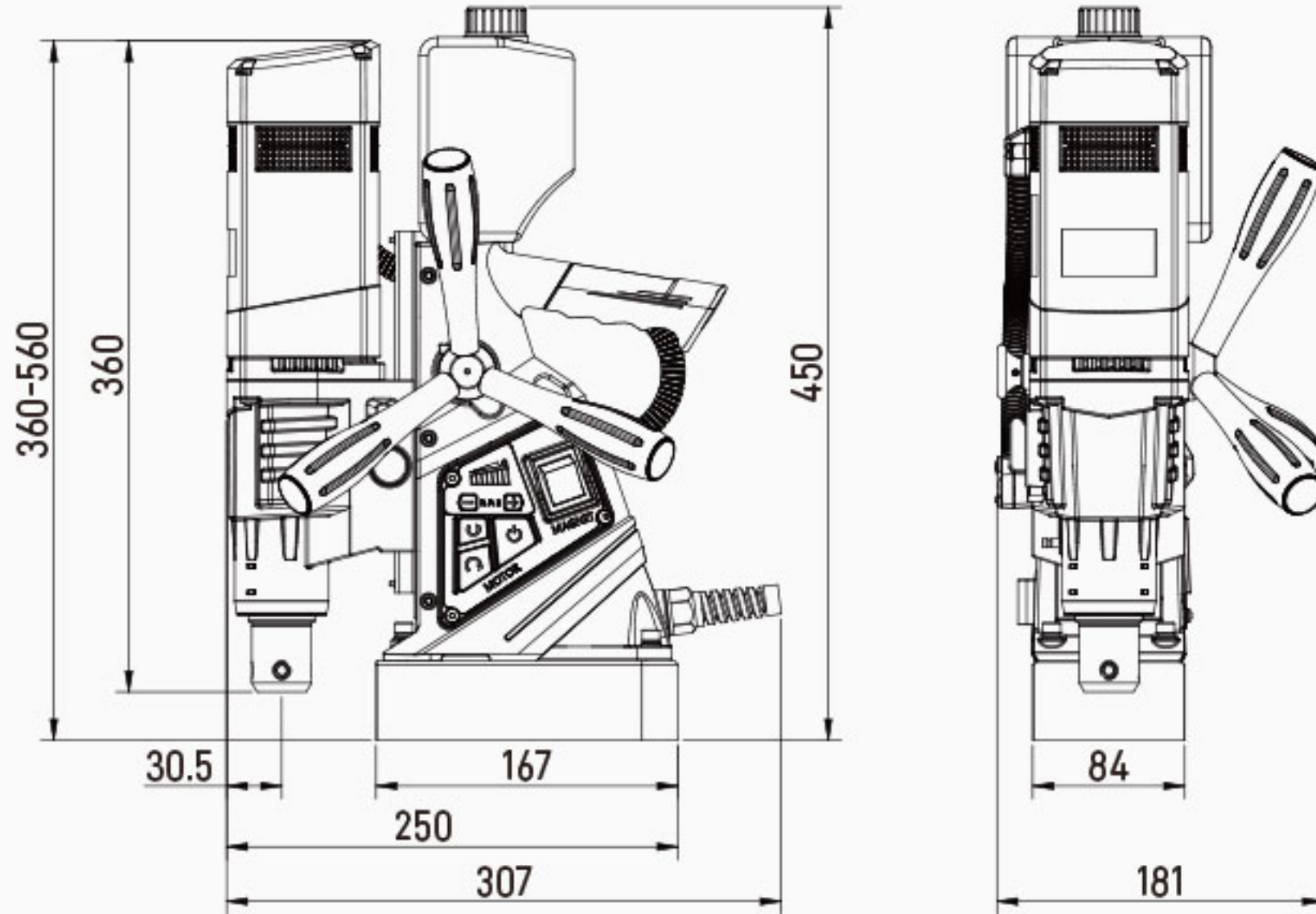

AC220V~240V 50~60HZ

额定输入功率 RATED INPUT POWER	1600W	钢板钻钻孔直径 THE DIAMETER RANGE OF ANNULAR CUTTER	≤ ϕ 50mm	磁座半吸 MAGNETIC BASE SEMI-SUCTION	✓
磁座吸力 MAGNETIC SUCTION	10000N	钢板钻钻孔深度 THE DRILLING DEPTH RANGE OF ANNULAR CUTTER	≤50mm	吸力指示 SUCTION FORCE INDICATION	✓
行程 STROKE	120mm	麻花钻直径 THE DIAMETER RANGE OF TWIST DRILL	≤ ϕ 20mm	电机缓启动 MOTOR SLOW START	✓
主轴可调高度 MAINSHAFT ADJUSTABLE HEIGHT	90mm	攻丝规格 TAPPING SPECIFICATIONS	≤M16	主电机过流保护 MAIN MOTOR CURRENT PROTECTION	✓
主轴接口类型 SPINDLE INTERFACE TYPE	ϕ 19.05mm	重量 WEIGHT	13KG	滑板锁止 SLIDING PLATE LOCKING	✓
磁座尺寸 MAGNETIC BASE SIZE	167*84*44mm	额定转速 RATED SPEED	Max 900rpm	电机正反转 MOTOR FORWARD AND REVERSE ROTATION	✓
外形尺寸 MACHINE SIZE	307*181*360(560)mm			六档电子调速 SIX-SPEED ELECTRONIC SPEED	✓
最小钢板厚度 THE MIN PROCESSING THICKNESS	10mm			负载恒速 CONSTANT SPEED UNDER LOAD	✓

主要配件: 冷却壶 / 扳手 / 安全带等。MAIN ACCESSORIES: COOLING POT / WRENCH / SAFETY STRAP, ETC.

上市时间: 2025年1月 TIME TO MARKET: JANUARY 2025

可选电源插头类型 OPTIONAL POWER PLUG TYPE

AC 220~240V					AC 110~127V	
英标插头 ENGLAND STANDARD PLUG	澳标插头 AUSTRALIA STANDARD PLUG	欧标插头 EUROP STANDARD PLUG	国标插头 CHINA STANDARD PLUG	工业插头 INDUSTRIAL PLUG	美标插头 AMERICA STANDARD PLUG	工业插头 INDUSTRIAL PLUG

